

STAP

Differential pressure controller – DN 15-50



Pressurisation & Water Quality › Balancing & Control › Thermostatic Control

ENGINEERING ADVANTAGE

STAP is a high-performing differential pressure controller that keeps the differential pressure over the load constant. This delivers accurate and stable modulating control, ensures less risk of noise from control valves, and results in easy balancing and commissioning. STAP's unrivalled accuracy and compact size make it particularly suitable for use on the secondary side of heating and cooling systems.

> **Pressure relief cone**

Ensures accurate differential pressure control.

> **Adjustable set-point and shut-off function**

Delivers desired differential pressure ensuring accurate balancing. Shut-off function makes maintenance easy and straightforward.

> **Measuring points with drain option**

Simplifies the balancing procedure, and increases its accuracy.



> Technical description

Application:

Heating and cooling systems.

Functions:

Differential pressure control
Adjustable Δp
Measuring point
Shut-off
Draining (accessory)

Dimensions:

DN 15-50

Pressure class:

PN 16

Max. differential pressure (Δp_V):

250 kPa

Setting range:

DN 15 - 20: 5* - 25 kPa
DN 32 - 40: 10* - 40 kPa
DN 15 - 25: 10* - 60 kPa
DN 32 - 50: 20* - 80 kPa

*) Delivery setting

Temperature:

Max. working temperature: 120°C

Min. working temperature: -20°C

Material:

Valve body: AMETAL®
Bonnet: AMETAL®
Cone: AMETAL®
Spindles: AMETAL®
O-rings: EPDM rubber
Membrane: HNBR rubber
Spring: Stainless steel
Handwheel: Polyamide
Smooth ends:
Nipple: AMETAL®
Sealing (DN 25-50): EPDM O-ring

AMETAL® is the dezincification resistant alloy of TA.

Marking:

Body: TA, PN 16/150, DN, inch size and flow direction arrow.
Bonnet: STAP, Δp_L 5-25, 10-40, 10-60 or 20-80.

Operating instruction

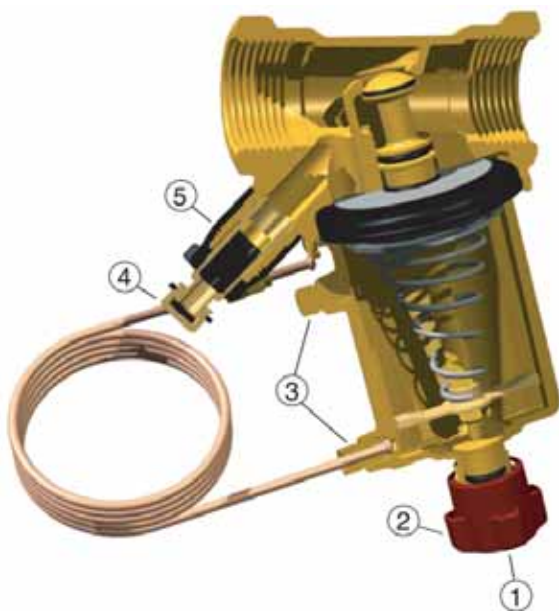

1. Setting Δp_L (allen key)
2. Shut-off
3. Connection capillary pipe
Venting
Connection measuring point STAP
4. Measuring point
5. Connection draining kit (accessory)

Measuring point

Remove the cover and then insert the probe through the self-sealing nipple.

Measuring point STAP (accessory) can be connected to the venting if the STAD valve is out of reach for measuring of differential pressure.

Drain

Draining kit available as accessory. Can be connected during operation.

Installation

Note! The STAP must be placed in the return pipe and with correct flow direction.

To simplify installations in tight spaces, the bonnet can be detached.

When extending the capillary pipe, use e.g. 6 mm copper pipe and extension kit (accessory). **Note!** The supplied capillary pipe must be included.

Balancing of system **with** presettable valves.
(Suitable for Application examples 1, 3, 4 and 5)

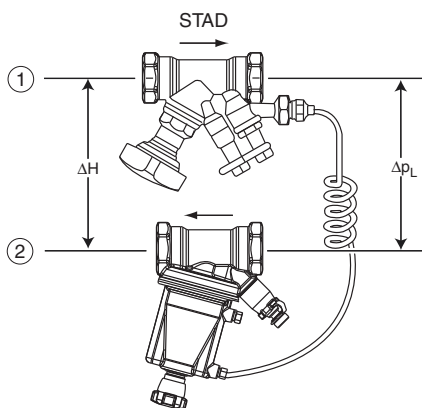

1. Inlet
2. Return

Balancing of system **with non** presettable valves.
(Suitable for Application example 2)

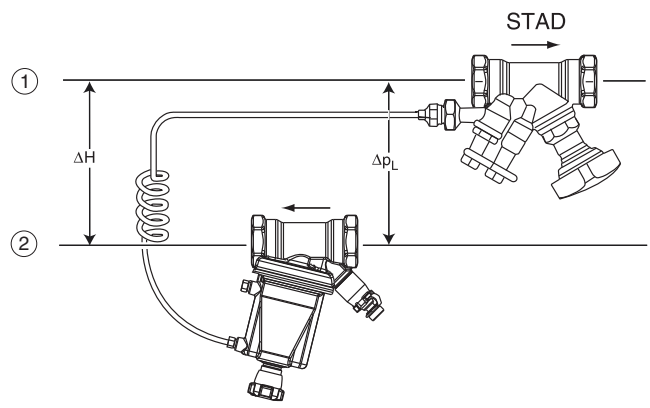

For further installation examples, see Handbook No 4 - Hydronic balancing with differential pressure controllers.
STAD – see catalogue leaflet "STAD".

Diagram

The diagram shows the lowest pressure drop required for the STAP valve to be within its working range at different flows.

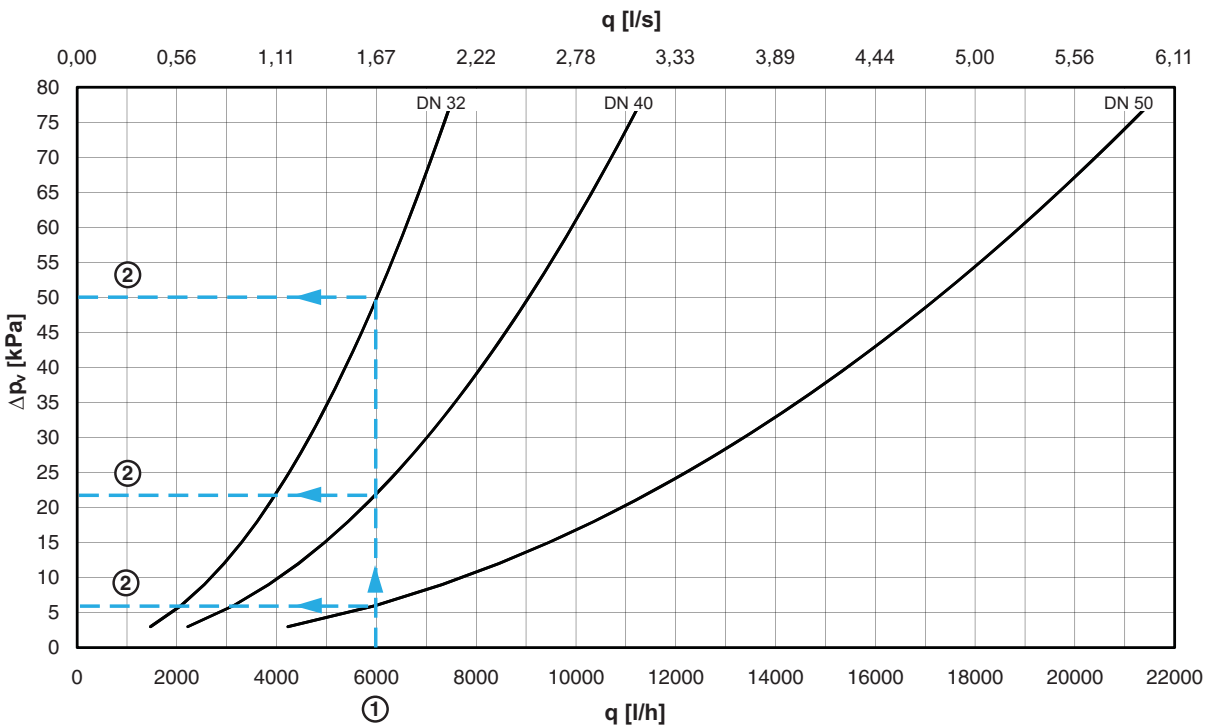
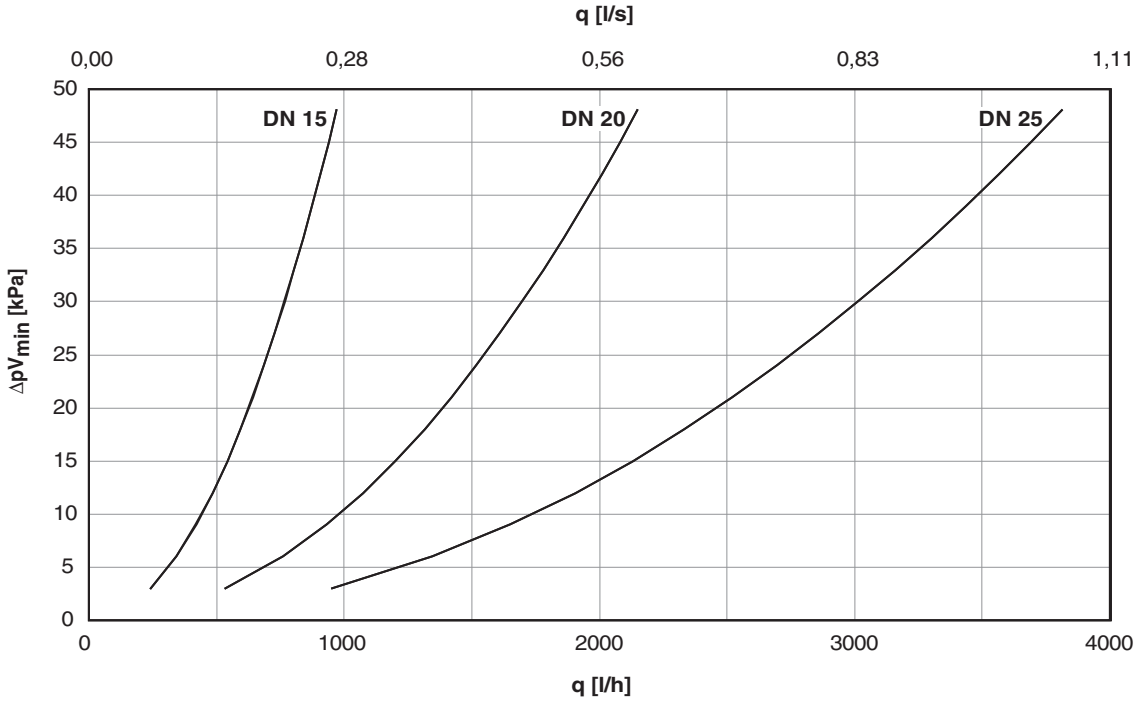

Example:

Desired flow 6000 l/h, $\Delta p_L = 23$ kPa and available differential pressure $\Delta H = 60$ kPa.

1. Desired flow (q) 6000 l/h.

2. Read the pressure drop ΔpV_{\min}

DN 32 $\Delta pV_{\min} = 50$ kPa

DN 40 $\Delta pV_{\min} = 22$ kPa

DN 50 $\Delta pV_{\min} = 6$ kPa

3. Calculate required available differential pressure ΔH_{\min} .

At 6000 l/h and fully open STAD the pressure drop is, DN 32 = 18 kPa, DN 40 = 10 kPa and DN 50 = 3 kPa.

$$\Delta H_{\min} = \Delta p_{\text{STAD}} + \Delta p_L + \Delta pV$$

DN 32: $\Delta H_{\min} = 18 + 23 + 50 = 91$ kPa

DN 40: $\Delta H_{\min} = 10 + 23 + 22 = 55$ kPa

DN 50: $\Delta H_{\min} = 3 + 23 + 6 = 32$ kPa

4. In order to optimise the control function of the STAP select the smallest possible valve, in this case DN 40. (DN 32 is not suitable since $\Delta H_{\min} = 91$ kPa and available differential pressure 60 kPa only).

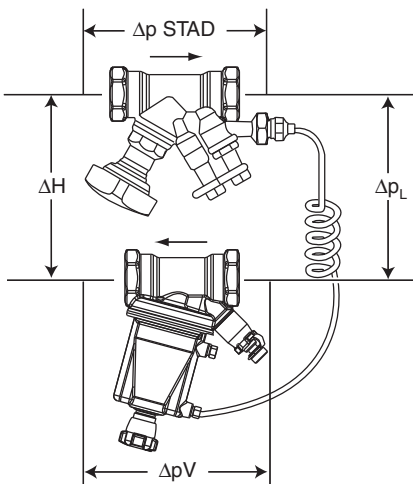

$$\Delta H = \Delta p_{\text{STAD}} + \Delta p_L + \Delta pV$$

TA recommends the software *TA Select* for calculating the STAP size. *TA Select* can be downloaded from www.tahydraulics.com

Working range

	Kv_{min}	Kv_{nom}	Kv_m
DN 15	0,07	1,0	1,4
DN 20	0,16	2,2	3,1
DN 25	0,28	3,8	5,5
DN 32	0,42	6,0	8,5
DN 40	0,64	9,0	12,8
DN 50	1,2	17,0	24,4

Note! The flow in the circuit is determined by its resistance, i.e. Kv_C : $q_C = Kv_C \sqrt{\Delta p_L}$

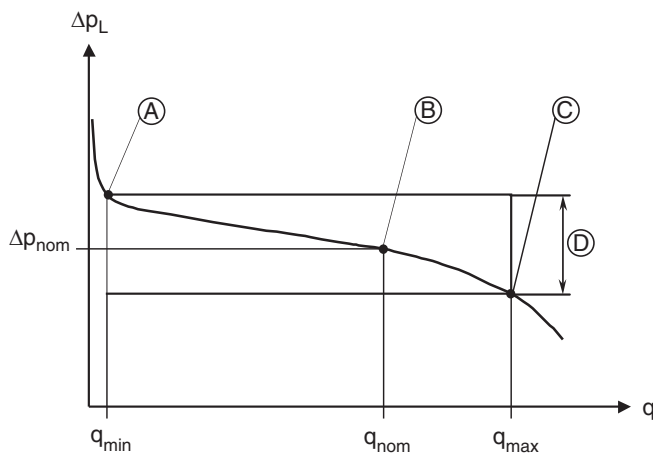

- A. Kv_{min}
- B. Kv_{nom} (Delivery setting)
- C. Kv_m
- D. Working range $\Delta p_L \pm 20\%$. STAP 5-25 and 10-40 kPa $\pm 25\%$.

Sizing

1. Select the desired Δp_L in the tables.
2. Select the same size of the valve as the pipe.
3. Check that the desired flow is smaller than the specified q_{max} . If not, select the nearest bigger dimension, alternatively a bigger Δp_L .

The tables are valid for:

$\Delta H \geq 2 \times \Delta p_L$, but the valve works properly between $\Delta H \sim 1,5 \times \Delta p_L$ to $250 \text{ kPa} + \Delta p_L$.

5-25 kPa

q [l/h]

DN	Δp_L [kPa]														
	5			10			15			20			25		
	q _{min}	q _{nom}	q _{max}	q _{min}	q _{nom}	q _{max}	q _{min}	q _{nom}	q _{max}	q _{min}	q _{nom}	q _{max}	q _{min}	q _{nom}	q _{max}
15	15	220	310	20	320	440	25	390	540	30	450	630	35	500	700
20	35	490	690	50	700	980	60	850	1200	70	980	1390	80	1100	1550

10-40 kPa

q [l/h]

DN	Δp_L [kPa]											
	10			20			30			40		
	q _{min}	q _{nom}	q _{max}	q _{min}	q _{nom}	q _{max}	q _{min}	q _{nom}	q _{max}	q _{min}	q _{nom}	q _{max}
32	130	1900	2690	190	2680	3800	230	3290	4660	270	3790	5380
40	200	2850	4050	290	4020	5720	350	4930	7010	400	5690	8100

10-60 kPa

q [l/h]

DN	Δp_L [kPa]								
	10			20			30		
	q _{min}	q _{nom}	q _{max}	q _{min}	q _{nom}	q _{max}	q _{min}	q _{nom}	q _{max}
15	20	320	440	30	450	630	40	550	770
20	50	700	980	70	980	1390	90	1200	1700
25	90	1200	1740	130	1700	2460	150	2080	3010

q [l/h]

DN	Δp_L [kPa]								
	40			50			60		
	q _{min}	q _{nom}	q _{max}	q _{min}	q _{nom}	q _{max}	q _{min}	q _{nom}	q _{max}
15	45	600	900	50	710	990	55	770	1080
20	100	1400	2000	110	1560	2190	120	1700	2400
25	180	2400	3500	200	2690	3890	220	2940	4260

20-80 kPa

q [l/h]

DN	Δp_L [kPa]											
	20			30			40			50		
	q _{min}	q _{nom}	q _{max}	q _{min}	q _{nom}	q _{max}	q _{min}	q _{nom}	q _{max}	q _{min}	q _{nom}	q _{max}
32	190	2680	3800	230	3290	4660	270	3790	5380	300	4240	6010
40	290	4020	5720	350	4930	7010	400	5690	8100	450	6360	9050
50	540	7600	10900	660	9310	13400	760	10800	15400	850	12000	17300

q [l/h]

DN	Δp_L [kPa]								
	60			70			80		
	q _{min}	q _{nom}	q _{max}	q _{min}	q _{nom}	q _{max}	q _{min}	q _{nom}	q _{max}
32	330	4650	6580	350	5020	7110	380	5370	7600
40	500	6970	9910	540	7530	10700	570	8050	11400
50	930	13200	18900	1000	14200	20400	1070	15200	21800

Application examples

1. Stabilising the differential pressure across a circuit with presettable radiator valves

In plants equipped with presettable radiator valves (TRV), it is easy to get a good result. The presetting of the radiator valves limit the flow so that overflows do not occur. STAP limits the differential pressure and prevents noise.

- STAP stabilises Δp_L
- The preset Kv-value of TRV limits the flow in each radiator.
- STAD is used for flow measuring, shut-off and connection of the capillary pipe.

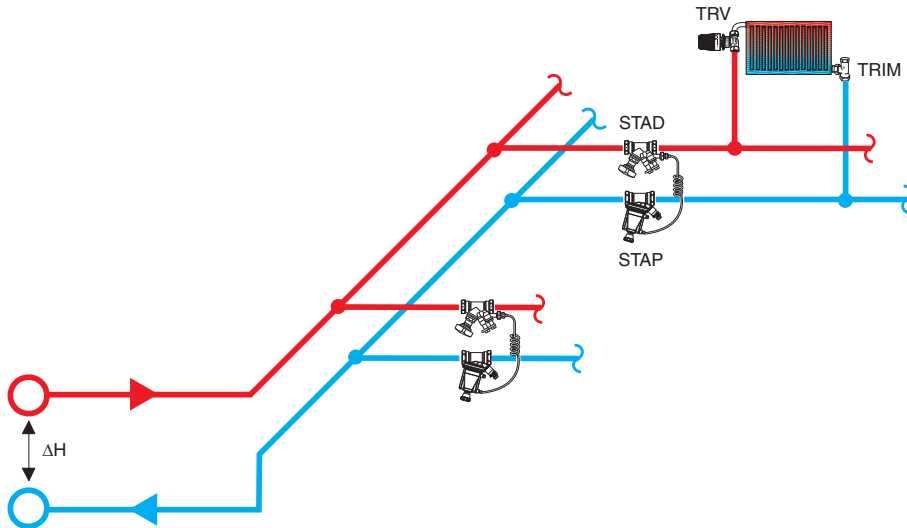

2. Stabilising the differential pressure across a circuit with non-presettable radiator valves

In plants equipped with non-presettable radiator valves it is not so easy to get an optimal result. Such radiator valves are common in older plants and will not limit the flow, which can be significantly too high in one or several circuits. Consequently, it is not enough that STAP limits the differential pressure across each circuit.

Letting STAP work together with STAD will solve the problem. STAD limits the flow to design value (using TA's balancing instrument to find the correct value). The correct distribution of the total flow between the radiators is however not achieved, but this solution can significantly improve a plant equipped with non-presettable radiator valves.

- STAP stabilises Δp_L
- There is no presettable Kv-value on the radiator valve in order to limit the flow in each radiator.
- STAD limits the total flow in the circuit.

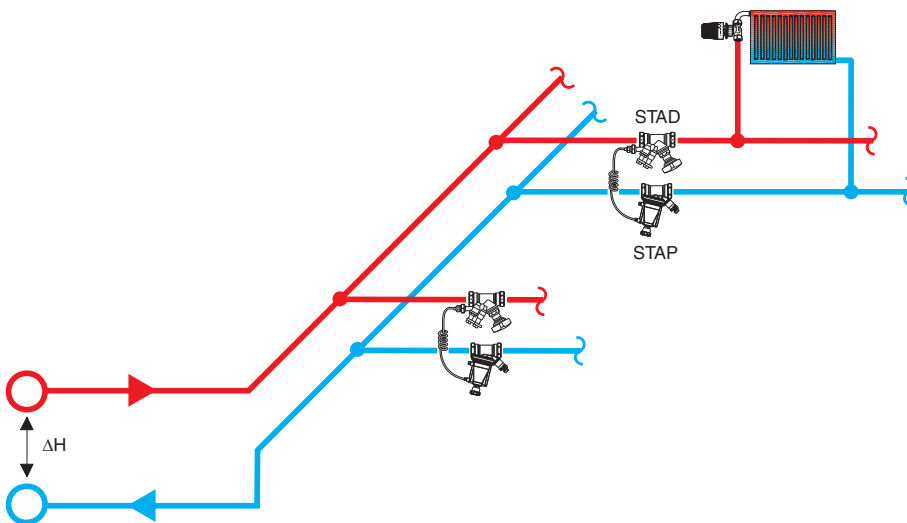

3. Stabilising the differential pressure across a circuit with control and balancing valves

When several small terminal units are close to one another, the differential pressure can be stabilised by using STAP in combination with STAD-1 across each circuit. STAD-2 for each terminal unit limits the flow and STAD-1 is used to measure the flow.

- STAP stabilises Δp_L .
- The set Kv-value in STAD-2 limits the flow in each terminal unit.
- STAD-1 is used for flow measuring, shut-off and connection of the capillary pipe.

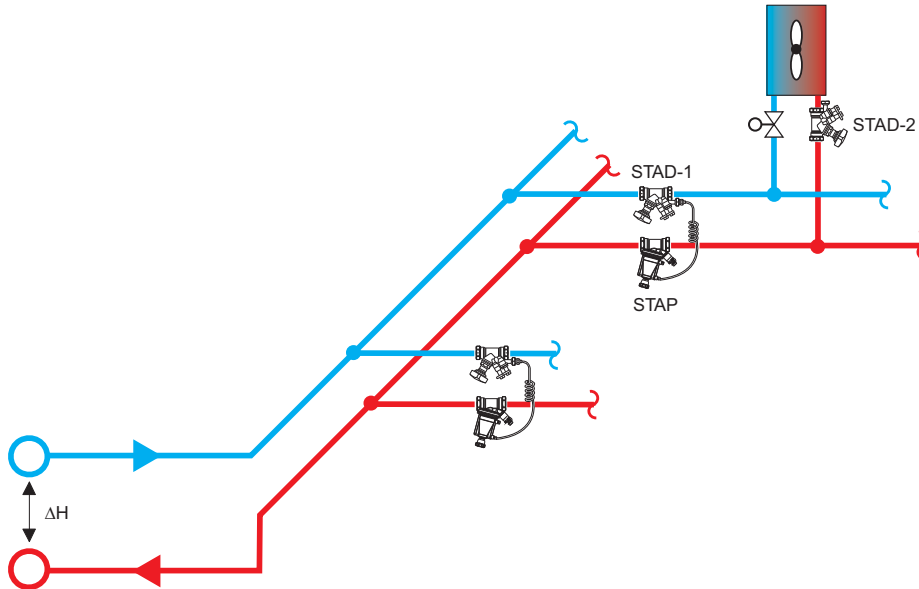

4. Stabilising the differential pressure across a riser with balancing valves (“Modular valve method”)

The “Modular valve method” is suitable when a plant is put into operation phase. Install one differential pressure controller on every riser, so that each STAP controls one module.

STAP keeps the differential pressure from the main pipe at a stable value out to the risers and circuits. STAD-2 downstream on the circuits guarantees that overflows do not occur. With STAP working as a modular valve, the whole plant does not need to be re-balanced when a new module is taken into operation. There is no need for balancing valves on the main pipes (except for diagnostic purposes), since the modular valves distribute the pressure out to the risers.

- STAP reduces a big and variable ΔH to a suitable and stable Δp_L .
- The set Kv-value in STAD-2 limits the flow in each circuit.
- STAD-1 is used for flow measuring, shut-off and connection of the capillary pipe.

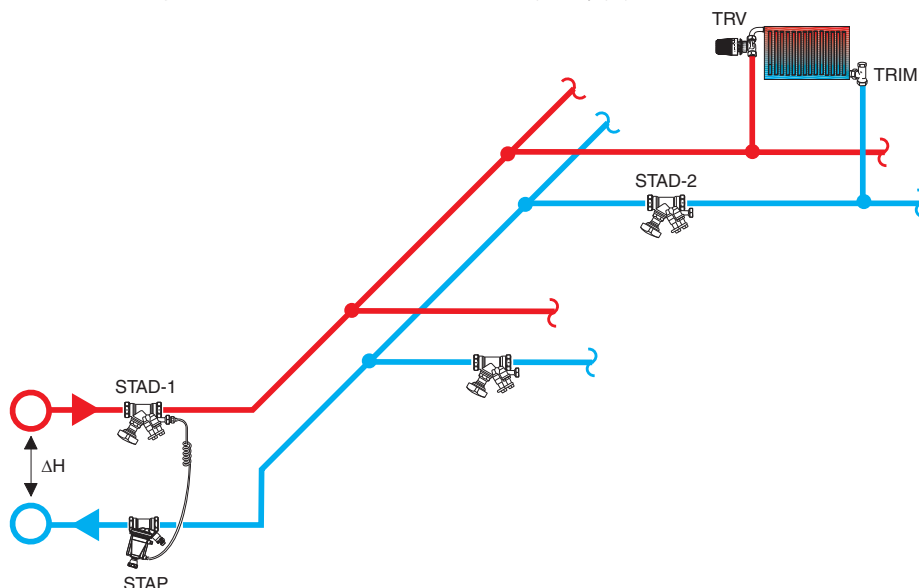

5. Keeping the differential pressure across a control valve constant

Depending of the design of the plant, the available differential pressure across some circuits can vary significantly with the load. To keep the correct control valve characteristic in such a case, the differential pressure across the control valves can be kept almost constant by a STAP connected directly across each control valve. The control valve will not be over-sized and the authority is and will remain close to 1.

If all control valves are combined with STAP, there is no need for other balancing valves, except for diagnostic purposes.

- STAP keeps Δp across the control valve constant, giving a valve authority ~ 1 .
- The Kvs of the control valve and the chosen Δp gives the design flow.
- STAD-1 is used for flow measuring, shut-off and connection of the capillary pipe.

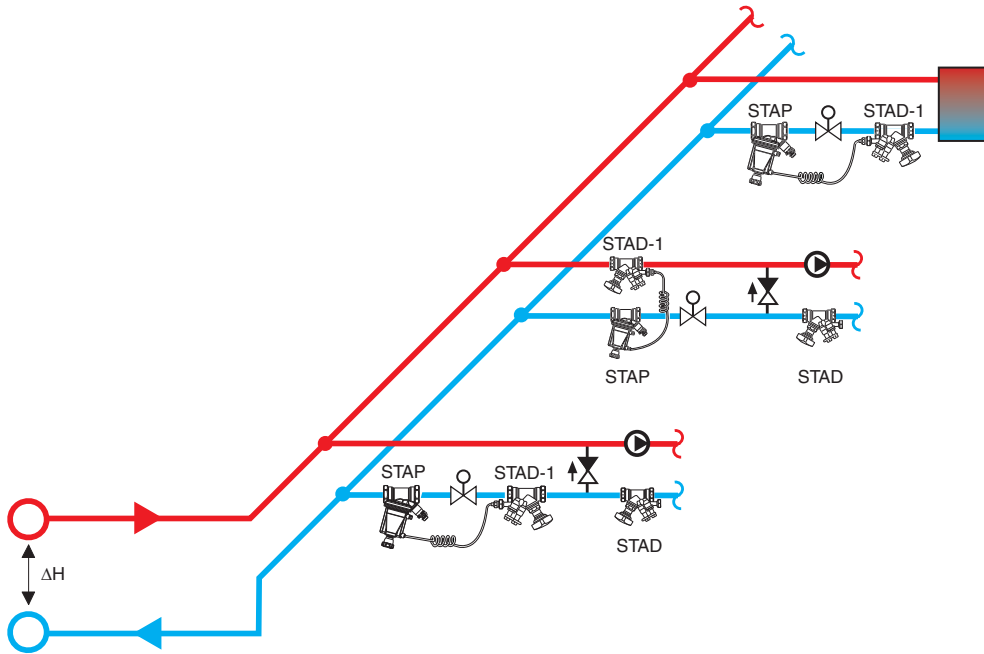

Sizing the control valve

A control valve should give a flow of 1000 l/h at a ΔH varying between 55 and 160 kPa.

- With a differential pressure of 10 kPa over the control valve, the Kvs will be 3,16.
- Control valves are normally available with Kvs-values according to the series 0,25 – 0,4 – 0,63 – 1,0 – 1,6 – 2,5 – 4,0 – 6,3
- Choose Kvs=2,5, which will give a Δp of 16 kPa. Since the STAP guarantees a high control valve authority, a low pressure drop over the control can be chosen. Therefore, choose the biggest Kvs value that gives a Δp above the minimum set point of STAP (i.e. 5, 10 or 20 kPa depending on size and type).
- Adjust STAP to give $\Delta p_l = 16$ kPa. Check the flow with TA's balancing instrument over STAD-1 and with the control valve fully open.

Articles

Female threads

1 m capillary pipe and transition nipples G1/2 and G3/4 are included.

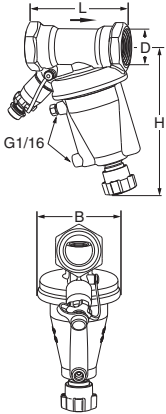

Article No	EAN	DN	D	L	H	B	Kv _m	Kg
5-25 kPa								
52 265-115*	7318793946607	15	G1/2	84	137	72	1,4	1,1
52 265-120*	7318793946706	20	G3/4	91	139	72	3,1	1,2
10-40 kPa								
52 265-132	7318793790002	32	G1 1/4	133	179	110	8,5	2,6
52 265-140	7318793790101	40	G1 1/2	135	181	110	12,8	2,9
10-60 kPa								
52 265-015*	7318793623201	15	G1/2	84	137	72	1,4	1,1
52 265-020*	7318793623300	20	G3/4	91	139	72	3,1	1,2
52 265-025	7318793623409	25	G1	93	141	72	5,5	1,3
52 266-315	7318793958501	15	Rc1/2	84	137	72	1,4	1,1
52 266-320	7318793958600	20	Rc3/4	91	139	72	3,1	1,2
52 266-325	7318793958709	25	Rc1	93	141	72	5,5	1,3
20-80 kPa								
52 265-032	7318793623805	32	G1 1/4	133	179	110	8,5	2,6
52 265-040	7318793623904	40	G1 1/2	135	181	110	12,8	2,9
52 265-050	7318793624000	50	G2	137	187	110	24,4	3,5
52 266-332	7318793958808	32	Rc1 1/4	133	179	110	8,5	2,6
52 266-340	7318793958907	40	Rc1 1/2	135	181	110	12,8	2,9
52 266-350	7318793959003	50	Rc2	137	187	110	24,4	3,5

Smooth ends

1 m capillary pipe and transition nipples G1/2 and G3/4 are included.

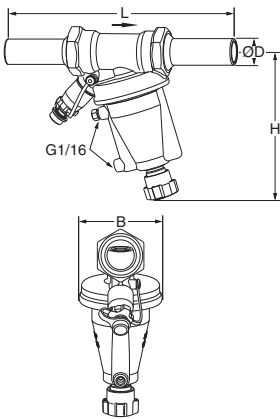

Article No	EAN	DN	D	L	H	B	Kv _m	Kg
5-25 kPa								
52 465-115	7318793949905	15	15	148	137	72	1,4	1,2
52 465-120	7318793950000	20	22	173	139	72	3,1	1,4
10-40 kPa								
52 465-132	7318793935304	32	35	242	179	110	8,5	3,0
52 465-140	7318793935403	40	42	265	181	110	12,8	3,4
10-60 kPa								
52 465-015	7318793934703	15	15	148	137	72	1,4	1,2
52 465-020	7318793934802	20	22	173	139	72	3,1	1,4
52 465-025	7318793934901	25	28	191	141	72	5,5	1,6
20-80 kPa								
52 465-032	7318793935007	32	35	242	179	110	8,5	3,0
52 465-040	7318793935106	40	42	265	181	110	12,8	3,4
52 465-050	7318793935205	50	54	287	187	110	24,4	4,3

→ = Flow direction

Kv_m = m³/h at a pressure drop of 1 bar and opening corresponding to the p-band (-20% respectively -25%).

*) Can be connected to smooth pipes by KOMBI compression coupling. See accessories or catalogue leaflet KOMBI.

G = Thread according to ISO 228. Thread length according to ISO 7/1.

Rc = Thread according to ISO 7 (≈ BS 21).

STAP/STAD

STAP/STAD package

For more information on STAD see separate catalogue leaflet

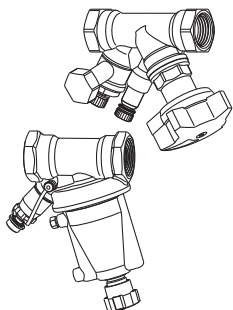

Article No	EAN	STAP DN	STAD DN
5-25 kPa			
52 265-101	7318793974303	15	15
52 265-102	7318793974402	20	20
10-40 kPa			
52 265-103	7318793974501	32	32
52 265-104	7318793974600	40	40
10-60 kPa			
52 265-001	7318793974709	15	10
52 265-002	7318793974808	15	15
52 265-003	7318793974907	20	20
52 265-004	7318793975003	25	25
20-80 kPa			
52 265-005	7318793975102	32	32
52 265-006	7318793975201	40	40
52 265-007	7318793975706	50	50

Accessories

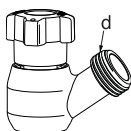

Draining kit STAP

Article No	EAN	d
52 265-201	7318793660404	G1/2
52 265-202	7318793660503	G3/4

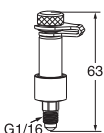

Measuring point STAP

Article No	EAN
52 265-205	7318793660602

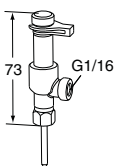

Measuring point, two-way

For connection of capillary pipe while permitting simultaneous use of TA's balancing instrument.

Article No	EAN
52 179-200	7318793784100



Extension kit for capillary pipe

Complete with connections for 6 mm pipe

Article No	EAN
52 265-212	7318793781505

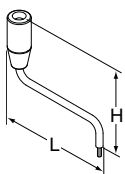

Setting tool Δp_L

Article No	EAN	L	H	
52 265-305	7318793975508	107	85	3 mm

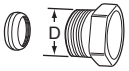

Compression connection KOMBI
See catalogue leaflet KOMBI.

Article No	EAN	D	Pipe Ø
53 235-109	7318792874901	G1/2	10
53 235-111	7318792875007	G1/2	12
53 235-112	7318792875106	G1/2	14
53 235-113	7318792875205	G1/2	15
53 235-114	7318792875304	G1/2	16
53 235-117	7318792875403	G3/4	15
53 235-121	7318792875601	G3/4	18
53 235-123	7318792875700	G3/4	22

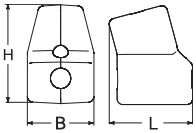

Insulation STAP
For heating/cooling

Article No	EAN	For DN	L	H	B
52 265-225	7318793658906	15-25	145	172	116
52 265-250	7318793659002	32-50	191	234	154

Spare parts

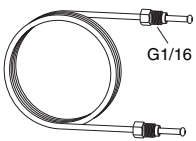

Capillary pipe

Article No	EAN	L
52 265-301	7318793661500	1 m



Plug
Venting

Article No	EAN
52 265-302	7318793661609

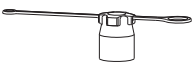

Protective cap
Draining

Article No	EAN
52 265-303	7318793661708

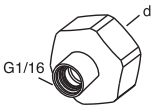

Transition nipple

Article No	EAN	d
52 179-981	7318793660206	G1/2
52 179-986	7318793660305	G3/4

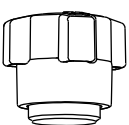

Handwheel

Article No	EAN	
52 265-900	7318793952202	DN 15-25
52 265-901	7318793952301	DN 32-50



The products, texts, photographs, graphics and diagrams in this document may be subject to alteration by TA Hydronics without prior notice or reasons being given.

For the most up to date information about our products and specifications, please visit www.tahydronics.com.

6-5-5 STAP 03.2011
