

M I T I



doors
windows

M I T I



**doors
windows**



Chi ama circondarsi di cose belle e armoniose trova nella linea di porte " I Miti" una risposta all'eleganza delle linee e al fascino delle calde armonie, che solo le porte in legno della COCIF sanno dare. Un grande pregio estetico che si accompagna alla più sofisticata tecnologia di produzione e all'elevata qualità dei materiali. I colori e le essenze, caldi e raffinati, riescono a valorizzare il gusto e l'eleganza di ambienti in cui si possono ritrovare il fascino e il prestigio di una casa italiana.

Those who love to surround themselves with beauty and harmony can find the answer to their needs in "The Miti" range. Only COCIF doors know how to give such elegant lines, warmth, charm and symmetry. Aesthetic excellence is accompanied by the most sophisticated production technology and high-quality materials. Rich, refined colours and wood bring out the taste and elegance of interiors that recall the charm and prestige of an Italian home.

M I T I



Armonia inglese
Tortora



Armonia
Rovere



Armonia
Faggio



Armonia
Bianco



Armonia vetro
Acciaio



Musa inglese
Verde petrolio



Musa vetro
Acero



Musa
Crema



Ninfa
Faggio



Ninfa
Giallo sabbia



Ninfa
Rovere



Ninfa vetro
Tanganika naturale



Ninfa inglese
Bianco



Urania 6
Tortora



Urania 6
Acquamarina



Urania 6
Ciliegio



Urania 5
Bianco



Urania 5
Tanganika



Urania 5
Noce nazionale



Atena
Crema



Atena
Ciliegio



Atena vetro
Acero



Atena inglese
Tanganika naturale



Atena
Bianco



Circe vetro
Ciliegio



Circe
Tortora

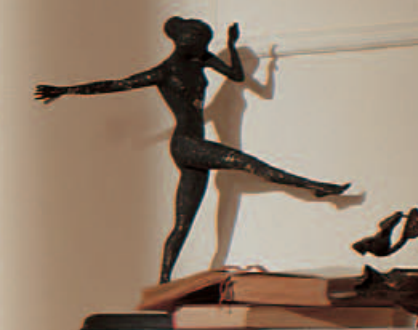



Circe vetro
Giallo chiaro



Circe
Noce nazionale

SEZIONI PANNELLI FORNITI DI SERIE PER TUTTI I MODELLI
TYPICAL DOOR LEAF SECTIONS FOR ALL DOOR MODEL



Bugna in MDF totalmente impiallacciata
Veneered MDF panel

M I T I
specifiche tecniche



Tipo Robot
Cromo
Chrome

Tipo Robot
Nero Mat
Mat Black

Tipo Robot
Mercurio
Mercury

Tipo Robot
Oro lucido
Polished gold color

SPECIFICHE TECNICHE

Tutti i modelli hanno cassonetto con guarnizione e coprifili sagomati ad incastro con aletta per consentire la regolazione muro, tutto in listellare impiallacciato. I pannelli sono rifiniti con bordatura su tre lati e sono di spessore 44 mm. Serratura, cerniere e maniglia in ottone lucido. Le porte a vetro sono sempre vetro escluso.

MOD. ARMONIA

Pannello a struttura tamburata impiallacciato in essenza. Cornici sovrapposte a formare due riquadri. VERSIONE A VETRO – Vano vetro nella specchiatura superiore.

VERSIONE INGLESE – Telaietto in legno massello per vetri singoli nel vano vetro superiore.

MOD. MUSA

Pannello a struttura piena e finestratura con bugna in MDF impiallacciata in essenza – cornice fermabugna sagomata.

VERSIONE A VETRO – Esclusione della bugna. VERSIONE INGLESE – Telaietto in massello per vetri singoli nel vano vetro.

MOD. NINFA – CIRCE

Pannello a struttura piena e due finestrature con all'interno bugne in MDF impiallacciate in essenza. Cornici fermabugne sagomate.

VERSIONE A VETRO – Esclusione bugna superiore. VERSIONE INGLESE – Telaietto in legno massello per vetri singoli nel vano vetro superiore.

MOD. URANIA 6 – 5

Pannello formato da fasce in listellare indeformabile impiallacciate in essenza.

6 – 5 bugne in MDF a diamante impiallacciate in essenza. Cornici fermabugne opportunamente sagomate che restano a filo del pannello.

MOD. ATENA

Ha le stesse caratteristiche del mod. URANIA ma due sole bugne.

VERSIONE A VETRO – Esclusione della bugna superiore.

VERSIONE INGLESE – Telaietto in legno massello per vetri singoli nel vano vetro superiore.

Le porte MITI sono disponibili solo nelle seguenti misure:

1 Anta 60 – 70 – 80 x 210 cm.

2 Ante 120 – 140 – 160 x 210 cm

(ante uguali).

TECHNICAL SPECIFICATIONS

Miti door frames are made of veneered blockboard wood and are complete with decorative adjustable architraves and gasket. The leaves are 44 mm thick and have three-side finished edge. Locks, hinges and handles are made of polished brass. Glazed solutions do not include glass.

ARMONIA MODEL

Veneered flush door with hollow-core structure and two decorative rectangular frames fixed on the panel. Glazed solution with opening for glass in the upper part of the leaf only.

English solution with solid wood framework for single sheets of glass in the upper part of the leaf only.

MUSA MODEL

Solid core door with a veneered raised panel of MDF. The raised panel has decorative beadings. Glazed solution with one opening for glass in the leaf.

English solution with solid wood framework for single sheet of glass.

NINFA AND CIRCE MODELS

Solid core door with two veneered raised panels of MDF. The raised panel has decorative beadings. Glazed solution with opening for glass in the upper part of the leaf only.

English solution with solid wood framework for single sheet of glass in the upper part of the leaf only.

URANIA 5 – 6 MODEL

Solid core door made of veneered blockboard strips with 5 or 6 bevelled panels of veneered MDF. The raised panel has decorative beadings.

ATENA MODEL

Same as URANIA model but with two panels only. Glazed solution with opening for glass in the upper part of the leaf only.

English solution with solid wood framework for single sheet of glass in the upper part of the leaf only.

The MITI doors will be provided in the following dimensions only:

Single leaf 60 – 70 – 80 x 210 cm.

Double leaf 120 – 140 – 160 x 210 cm

(leaves in the same dimensions only).

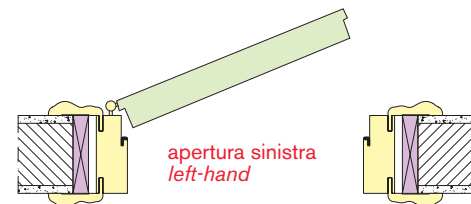
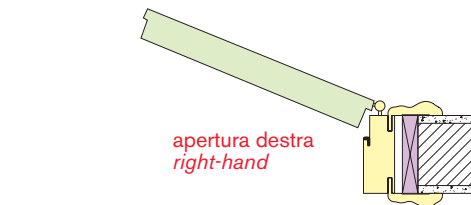

SEZIONE ORIZZONTALE
HORIZONTAL CROSS-SECTION

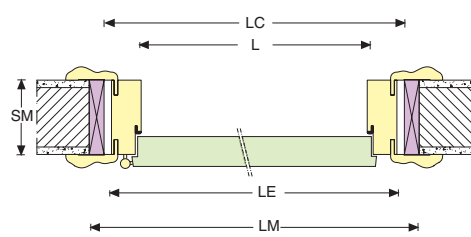

SEZIONE VERTICALE
VERTICAL CROSS-SECTION

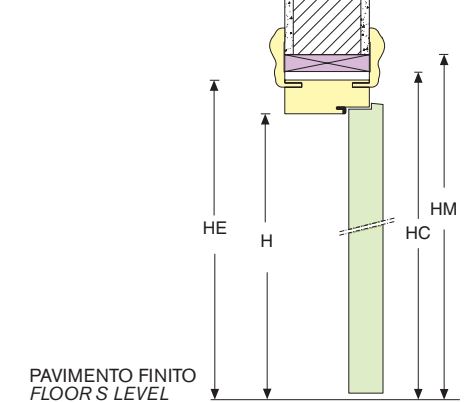

L	H	SM	LE/HE	LC/HC	LM/HM
Larghezza luce netta Opening width Largeur de passage Lichte Breite	Altezza luce netta Opening height Hauteur du passage Lichte H he	Spessore muro Wall thickness Epaisseur du mur Wandst rke	Esterno cassonetto External frame dimensions Mesure hors tout Zargenaußenmaße	Interno controtelaio Subframe opening Mesure du precadre Gegenzargen ffnung	Vano muro Wall opening Ouverture du mur Wand ffnung
cm 60 cm 70 cm 80 cm 120	cm 210 cm 210 cm 210 cm 210	cm 8/10 cm 10,5/12,5	cm 67/214 cm 77/214 cm 87/214 cm 127/214	cm 68,5 X 215 cm 78,5 X 215 cm 88,5 X 215 cm 128,5 X 215	cm 75/220 cm 85/220 cm 95/220 cm 135/220

SCORREVOLE INTERNO

Esistono due tipi di cassaporta metallica predisposti per lo scorrimento di un pannello al suo interno; questi sono distinti per muro finito ad intonaco o per parete in cartongesso.

Per spessore muro finito 10,5 gli unici modelli che possono sempre scorrere all'interno sono i mod. URANIA e ATENA.

Per la sola cassaporta su muro ad intonaco spessore 10,5 pu scorrere anche il modello CIRCE.

Tutti gli altri modelli sono senz'altro esclusi.

La porta fornita completa di stipite con feltrini e coprifili ad incastro. Nei casi con rivestimento, su un lato porta verr montato un coprifilo con aletta che consente di coprire muri fino a cm 12,5.

Maniglia ad incasso in ottone lucido e serratura a gancio.

INTERIOR SLIDING

There are two different kinds of metal door cases the door-leaf can slide in. They differ from one another according to the type of wall - whether concrete or gypsum.

In gypsum walls the door case allows one to use the URANIA and ATENA models only.

In concrete walls the models that can be used are URANIA, ATENA and CIRCE.

All other models cannot be used as an interior sliding door.

The door includes a frame with felt pads and adjustable architraves. In those with facing, the frame includes an adjustable architrave that covers the wall until 12,5 cm.

Embedded handle in polished brass and clasp lock included.

SEZIONE ORIZZONTALE
HORIZONTAL CROSS-SECTION

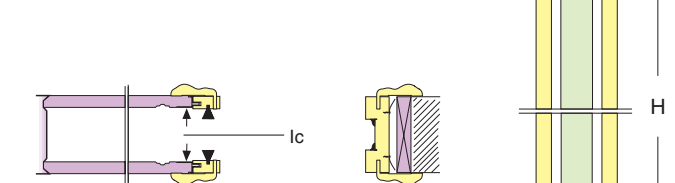
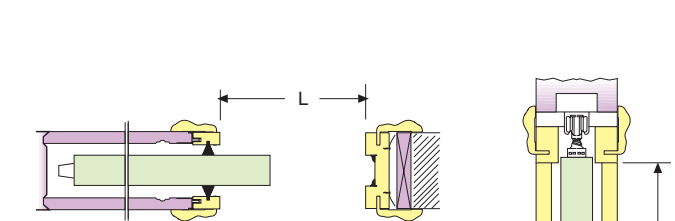

SEZIONE VERTICALE
VERTICAL CROSS-SECTION

L	H	IC	
Larghezza luce netta Opening width Largeur de passage Lichte Breite	Altezza luce netta Opening height Hauteur de passage Lichte H he	Larghezza interna controtelaio Subframe internal width Mesure interieur du precadre Gegenzargeinnenst rke	Modelli possibili Available models Mod le possible T rtyp
cm 60 cm 70 cm 80 cm 120 (60+60)	cm 210 cm 210 cm 210 cm 210	cm 7 cm 9	Atena Urania Circe Tutti i modelli All miti models

SCORREVOLE ESTERNO

Porta fornita completa di binario di scorrimento e cassetta copribinario con la stessa finitura dello stipite, maniglia a incasso in ottone lucido.

EXTERIOR SLIDING

The door includes a sliding rail and a rail-covering case with the same finish as the frame. Embedded handle in polished brass included.

SEZIONE ORIZZONTALE
HORIZONTAL CROSS-SECTION

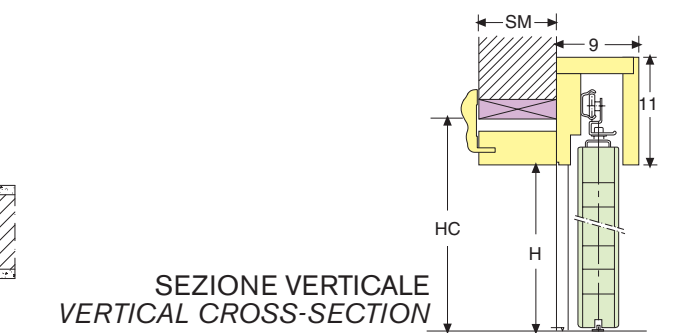
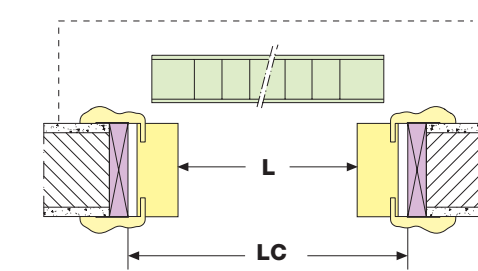

SEZIONE VERTICALE
VERTICAL CROSS-SECTION

L	H	SM	LC/HC
Larghezza luce netta Largeur de passage Opening width Lichte Breite	Altezza luce netta Opening height Hauteur de passage Lichte H he	Spessore muro Wall thickness Epaisseur du mur Wandst rke	Interno controtelaio Subframe opening Mesure du precadre Gegenzargen ffnung
cm 60 cm 70 cm 80 cm 120 (60+60)	cm 210 cm 210 cm 210 cm 210	cm 8/10 cm 10,5/12,5	cm 68,5/215 cm 78,5/215 cm 88,5/215 cm 128,5/215

**LACCATI OPACHI
DULL PAINTS**



bianco
white



giallo chiaro
light yellow



giallo sabbia
sand yellow



tortora
turtle-dove



grigio perla
pearl grey



crema
cream



acquamarina
aquamarine



azzurro
light blue

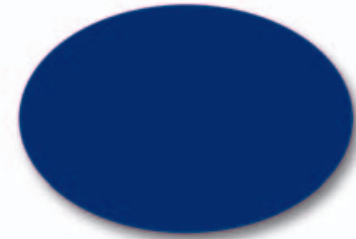

blu
blue



verde petrolio
petroleum green



grigio muschio
moss grey



nero
black

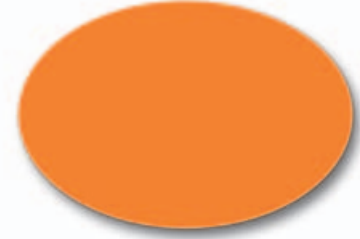

mandarino
tangerine



rosso orientale
oriental red

**SPECIE LEGNOSE NOSTRO TIPO OPACO
COCIF MAT VENEERS**



mogano
mahogany



noce tanganica
walnut tanganika



tanganica naturale
natural tanganika



faggio
beech



ciliegio
cherry



rovere
oak



noce nazionale
italian walnut



acero
maple

I laccati Blu, Verde petrolio, Grigio muschio, Rosso orientale, Nero sono disponibili anche in versione goffrata.
The following paints are also available in a special embossed finish: Blue, Petroleum green, Moss grey, Oriental red, Black.

COCIF si riserva la facoltà, qualora ne ravvisi la necessità, di apportare in ogni momento senza preavviso modifiche ai materiali, ai colori e alle specifiche tecniche dei prodotti a catalogo.
Cocif reserves the right to make any alterations to the materials, colours and technical specifications without any prior notice, in case Cocif deems this necessary.

COCIF

società cooperativa

via ponte ospedaletto, 1560 longiano italy

tel 0547 56144 - fax 0547 54094

info@cocif.com - www.cocif.com