



Electrical Solutions

Complete suspension systems for
a variety of electrical services



- Aesthetically pleasing
- Easy and efficient installation
- Complete off-site solutions

C-Clip
Page 10

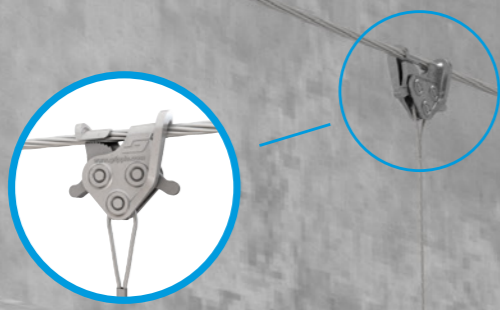

Catenary Kit
Page 10



Express
Page 8

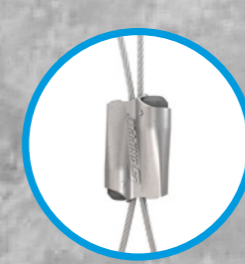

Y-Fit
Page 11

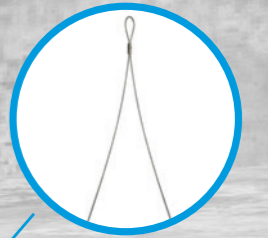

Standard Hanger
Page 7



Universal
Bracket
Page 13

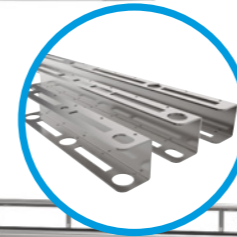

Trapeze
Page 4

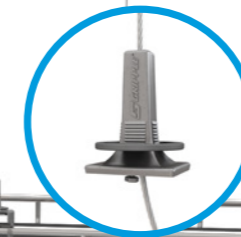

Trapeze Plus
Trapeze Plus FR
Page 5-6



G-Bracket
Page 12

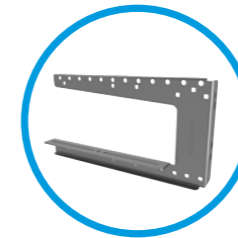

The **Gripple**® range of supports and hangers for electrical applications has been developed to provide a fast and versatile solution for suspending all types of electrical containment.

Gripple products are designed to save time, labour and reduce costs by making the installation quicker and easier. Supplied in ready-to-use kits, the products in this range are lightweight, require no on-site cutting and reduce the time spent at height, offering enormous health and safety benefits for your project.

Scan to explore
the electrical
application online



Gripple suspension kits provide complete solutions for electrical installations

Products shown are for internal use only. Images shown for illustrative purposes only. Please refer to product installation instructions for full information.

Trapeze (TZ)

Ideal for fast suspension of brackets or channel for tray, trunking and basket.

- Tapered design - accommodates all slots sizes
- Discreet - fits completely inside the channel
- Pre-fits onto channel to ease working at height
- Aesthetic design
- Available as an accessory for multi-tiered installations
- Sizes available; No.2 45 kg, No.3 90 kg and No.4 225 kg with a 5:1 safety factor
- Also available in black (see page 18)



All hangers are supplied as ready-to-use kits with a length of wire rope and end fixing of your choice.



“Gripple kits not only complement the architecture of a building but are also installed quickly and efficiently”

Contracts Engineer - Weavers Triangle

[End Fixings - Page 14](#)

A wide selection of end fixing options to suit your application

[Accessories - Page 16](#)

Additional products designed to help with your installation

Trapeze Plus (MTZ)

The all-steel Trapeze Plus is packed with features to make channel suspension even more secure and durable.

- Reduced time working at height: pre-install into channel using the washer/nut or QT fixing supplied
- Tool free setting
- Easy-to-use integral release button to allow finite adjustment
- Tighten the locking screw for ultimate security
- Channel can be multi-tiered to optimise space
- Full range of end fixings available
- Sizes available; No.2 45 kg, No.3 90 kg and No.4 225 kg with a 3:1 safety factor



Coming Soon – a new Quick Twist foot for the Trapeze Plus for even faster installation

All hangers are supplied as ready-to-use kits with a length of wire rope and end fixing of your choice.



“Less material on site and fewer deliveries reduces the CO₂ and helps the BREEAM rating”

Project Engineer, Kershaws - Flitwick Leisure Centre

[Installation System Design Service](#)

Submit your drawings and our technical team will provide bespoke product specification based on your project requirements

[Sales Enquiries](#)

Call our friendly team on
+44 (0) 800 018 4264

Trapeze Plus FR (MTZ-F)

The all-steel Trapeze Plus FR is supplied with stainless steel wire for the suspension of services where fire resistance is required.

- Reduced time working at height: pre-install into channel using the washer/nut supplied
- Fire Rated: BRE Certified up to F120 in accordance with BS476
- Part 20 / DIN4102 Part 2. Certification available with load limits and exposure times
- Tool free setting: Easy-to-use integral adjustment button
- Tighten the locking screw for ultimate security
- Channel can be multi-tiered to optimise space
- Stud, Eyelet, 90° Eyelet end fixings available
- Supplied with Stainless Steel wire
- Sizes available; No.2 45 kg, No.3 90 kg and No.4 225 kg with a 3:1 safety factor



All hangers are supplied as ready-to-use kits with a length of wire rope and end fixing of your choice.



Standard Hanger (HF)

The Standard Hanger presents an ideal solution to fulfil a variety of electrical suspension requirements.

- Up to 6 times faster to install than traditional suspension systems
- Versatile
- Simple to use
- Adjustable using key (provided with kits)
- Strong, safe and industry approved
- Load ratings up to 325 kg with a 5:1 safety factor
- Also available in black (see page 18)



All hangers are supplied as ready-to-use kits with a length of wire rope and end fixing of your choice.



“We have found Gripple to be quick and easy to assemble all manner of M&E services. It has proven to be strong, reliable, versatile and aesthetically pleasing”

Site Manager, Willmott Dixon

“The Gripple system is excellent in terms of cleanliness, time saving and safety”

Site Manager - Kershaw, Woodpecker Hall Primary School

[End Fixings - Page 14](#)

A wide selection of end fixing options to suit your application

[Accessories - Page 16](#)

Additional products designed to help with your installation

[Installation System Design Service](#)

Submit your drawings and our technical team will provide bespoke product specification based on your project requirements

[Sales Enquiries](#)

Call our friendly team on
+44 (0) 800 018 4264

Express (XP)

The Express No. 2 offers an instant locking system to make adjustment even easier.

- The system incorporates an integral adjustment mechanism for convenience
- Up to 6 times faster to install than traditional methods
- Keyless operation
- Discreet and aesthetic design
- Express No. 2 load rated at 45 kg with a 5:1 safety factor
- Also available in black (see page 18)



All hangers are supplied as ready-to-use kits with a length of wire rope and end fixing of your choice.



“Gripple kits helped us to complete the job on time, whilst also reducing our embodied carbon”

Site Supervisor, Gateway Primary Free School

[End Fixings - Page 14](#)

A wide selection of end fixing options to suit your application

[Accessories - Page 16](#)

Additional products designed to help with your installation

Angel (AL)

Our latest innovation, designed for architectural lighting suspensions where aesthetics are important.

- Simple one-handed operation for easy adjustment
- Contemporary design to complement the overall suspension
- Extensive range for use with most luminaires
- Suitable for loads up to 15 kg with a 5:1 safety factor, to accommodate a range of suspension requirements
- Supplied in convenient, ready-to-use kits in lengths up to 10 metres as standard
- Uses 1.5 mm wire rope to make the suspension as discreet as possible
- As standard, all kits come complete with the aesthetic ‘Top Hat Barrel’ ceiling fixing with M6 thread. Other ceiling fixings, e.g. Loops, Studs, Magnetic Pads are available on request



INNOVATION

The latest innovation from Gripple

[Installation System Design Service](#)

Submit your drawings and our technical team will provide bespoke product specification based on your project requirements

[Sales Enquiries](#)

Call our friendly team on +44 (0) 800 018 4264

Catenary Kit and C-Clip

Create secure, overhead spans by running high strength wire rope between two fixing points. Ideal for applications where no direct vertical anchor point is available. The Gripple C-Clip, an innovative twist-on/off device, allows you to suspend from anywhere along the span.



- Visually discreet and lightweight
- Can be fitted retrospectively
- No tools needed to install
- Available in 3 mm and 6 mm wire rope diameters, for suspensions up to 100 kg per span
- C-Clip allows horizontal and vertical adjustment
- Cams lock solidly in place, even at angles up to 60°

All hangers are supplied as ready-to-use kits with a length of wire rope and end fixing of your choice.



Y-Fit and Y-Fit Accessory

Single hanger with dual suspension points, which improves stability and centre of gravity.

- Y-Fit is a one piece suspension, ideal for shorter drop lengths
- Y-Fit Accessory is designed for use with a Standard Hanger or Express Hanger kit, for longer drops and increased adjustment
- Ideal for suspending cable basket and tray without the need for channel
- Available with a range of end fixings, and leg lengths to suit your specification



All hangers are supplied as ready-to-use kits with a length of wire rope and end fixing of your choice.



“Gripple Catenary kits were quick to install and offer improved aesthetics”

Site Supervisor, B&Q, Bedford

“Ideal for use with a Gripple Catenary Kit”

Contractor, Tesco, Leeds

End Fixings - Page 14

A wide selection of end fixing options to suit your application

Accessories - Page 16

Additional products designed to help with your installation

Installation System Design Service

Submit your drawings and our technical team will provide bespoke product specification based on your project requirements

Sales Enquiries

Call our friendly team on
+44 (0) 800 018 4264

G-Bracket

Bespoke hanger for cable tray and basket, allowing easy loading and unloading of cables.

- For use with a Y-fit or Y-fit Accessory with a Snap Hook end fixing
- Cut from heavy gauge steel
- Requires only one hole to be drilled for the entire installation
- Creates a well-balanced and secure hanger
- Can be joined together by stacking, or positioning side by side, and securing with coupling bolts

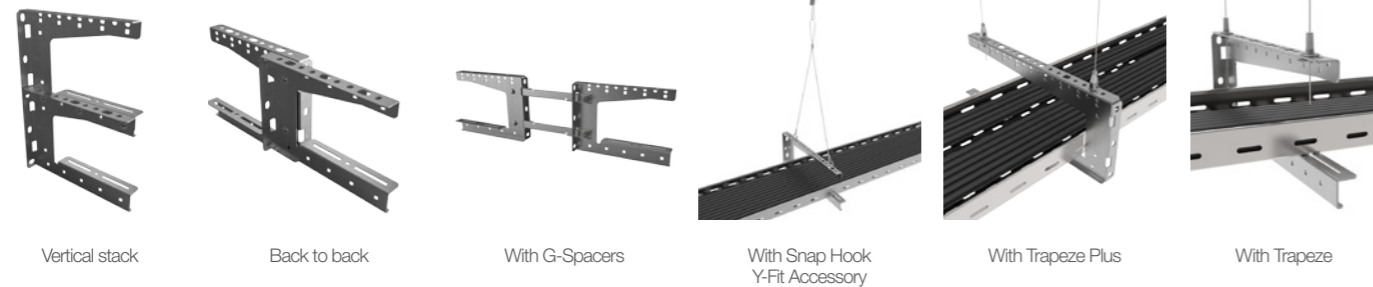
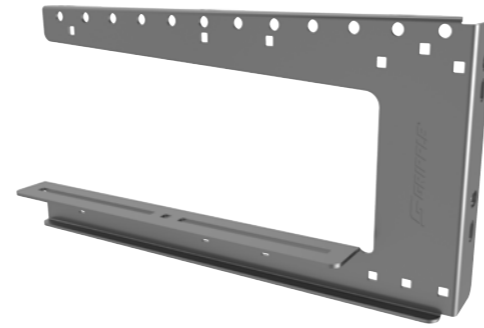

Available in four sizes



End Fixings - Page 14

A wide selection of end fixing options to suit your application

Accessories - Page 16

Additional products designed to help with your installation

Universal Bracket

Gripple Universal Brackets are perfect for multi-service suspensions or multi-tiered services as a containment bearer

- Pre-Cut - no requirement to cut to length; Gripple Universal Brackets are supplied in ready to use lengths
- Quick and easy installation - Gripple Universal Brackets can be supplied in kit form with Trapeze hangers and/or QT Universal Clamps
- Secure - robust design facilitates most applications and tray/basket can be fixed to the bracket with ease
- Versatile - can be suspended using Trapeze hangers or threaded rod
- Saves labour - eliminates the need for cutting channel/strut on site, allowing more productive use of labour
- Improves health and safety - no tools or "hot works" permit required for installation

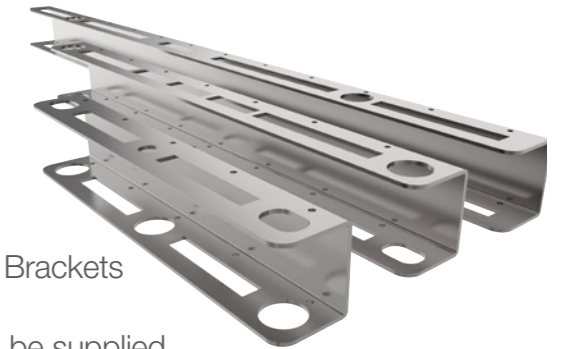

Available in sizes 230, 380, 640, 1020, 1200 mm

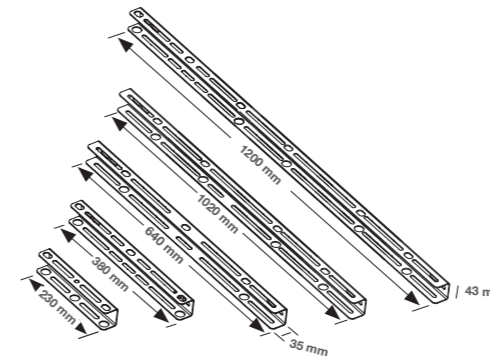

Mounting Concepts

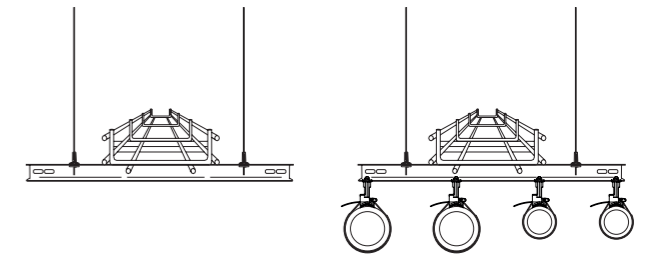

Installation System Design Service

Submit your drawings and our technical team will provide bespoke product specification based on your project requirements

Sales Enquiries

Call our friendly team on
+44 (0) 800 018 4264

End Fixings

All Gripple hanger kits are supplied with pre-crimped end fixings and your choice of wire rope length, suitable for installation into any substrate.



Loop

- Ideal for looping around purlins, beams, roof trusses and other suitable building features
- Available up to 325 kg SWL, with a 5:1 safety factor
- Available in Stainless Steel

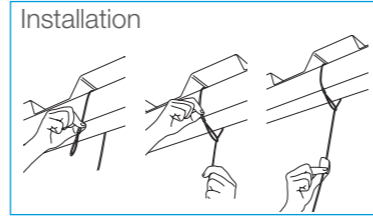

25 mm Wedge

- Ideal for fixing into the re-entrant channel of several composite floor deckings (R51, CF51, Holorib, MD50 and MF55)
- Available up to 90 kg SWL, with a 3:1 safety factor
- Comes as a ready-to-use kit with wire and Hanger

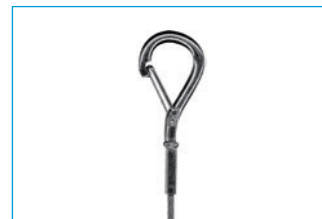
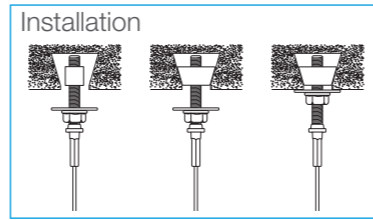

Snap Hook

- Quick and easy attachment to cable basket, purlin clips, light fittings
- Available in Gripple sizes No.2 and No.3 up to 90 kg SWL, with a 5:1 safety factor

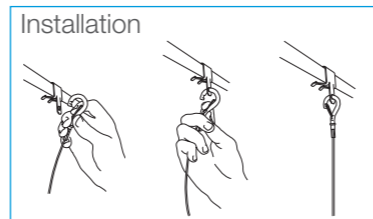

Stud

- Ideal for anchoring into concrete ceilings and Channel Nuts
- Supplied with a Drop-in Anchor
- Available up to 225 kg SWL, with a 5:1 safety factor
- Available in Stainless Steel

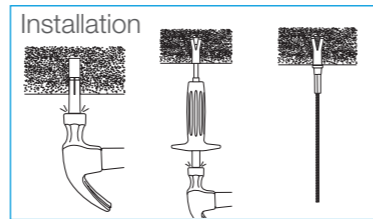

90° Eyelet

- Ideal for fixing into concrete, steel or wood using gas or powder activated tools or appropriate screws
- Available in Gripple sizes No.1, No.2 and No.3 up to 90 kg rated at 5:1 SWL

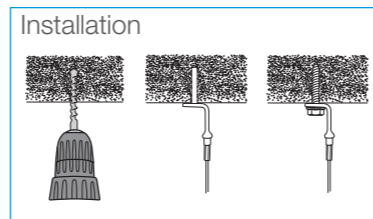

Channel Nut

- Designed for fixing directly into Channel
- Available in Gripple sizes No.2 and No.3
- Comes as a ready-to-use kit with wire and Hanger

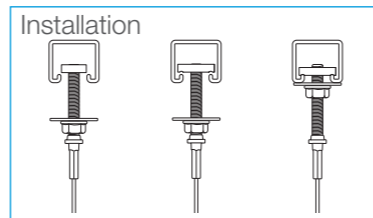

Spider

- A cast-in-place concrete insert solution for hanging mechanical & electrical services
- Swivel Toggle provides fast attachment of Wire Hangers No.2 and No.3 up to 90 kg at 5:1 SWL
- Also available in the following thread sizes: M8 & M10

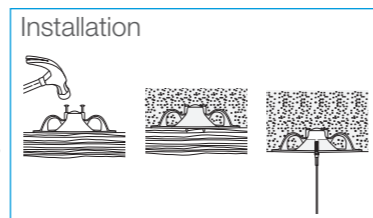

























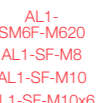



Other end fixings are available. Contact our technical team for details.





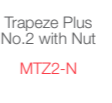
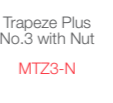



Product Codes

Standard product codes for Gripple hangers:

1 CHOOSE YOUR PRODUCT

 Standard Hanger No.1 HF1	 Standard Hanger No.2 HF2	 Standard Hanger No.3 HF3	 Standard Hanger No.4 HF4	 Standard Hanger No.5 HF5	 Express No.1 XP1	 Express No.2 XP2	 Angel Male AL1-SF4-M420 AL1-SF-M5 AL1-SM6F-M620 AL1-SF-M8 AL1-SF-M10 AL1-SF-M10x6 AL1-SF-M13	 Angel Swivel AL1-SF4W AL1-SF6W AL1-SF8W AL1-SM4W AL1-SM6W AL1-SM8W
 Angel Female AL1-SF4 AL1-SF6	 Angel Hook AL1-ISH	 Angel Y-Fit AL1-YTG-300* <small>*Also available in 150 and 400 mm leg lengths. For codes see page 00</small>	 Angel Signage 5 mm AL1-SL5	 Angel Rail AL1-SR	 Angel Disc AL1-SD	 Stainless Steel Hanger No.2 - HF2-S	 Stainless Steel Hanger No.3 - HF3-S	
 Trapeze No.2 TZ2	 Trapeze No.3 TZ3	 Trapeze No.4 TZ4	 Trapeze No.2 with Cable basket Adaptor TZ2 <small>* Add the code CB6 after wire length for example TZ2-LG-3M-CB6</small>	 Trapeze Plus No.2 MTZ2	 Trapeze Plus No.3 MTZ3	 Trapeze Plus No.4 MTZ4	 Trapeze Plus FR No.2 MTZ2-F	 Trapeze Plus FR No.3 MTZ3-F
				 Trapeze Plus No.2 with Nut MTZ2-N	 Trapeze Plus No.3 with Nut MTZ3-N	 Trapeze Plus No.4 with Nut MTZ4-N	 Trapeze Plus FR No.4 MTZ4-F	

2 CHOOSE YOUR END FIXING

 Loop LG	 25 mm Wedge DW258G	 Snap Hook HG	 Stud M8 x 45 mm S8G*	 Fire Rated 90° Eyelet EY906G*	 Channel Nut CN8G	 Spider STG	 C-Clip 3 mm CC3	 C-Clip 6 mm CC6
--	---	---	---	--	---	---	--	--

Stud available in M6, M8 or M10. Barrel available in M6 or M8. Please substitute the () for the size required when ordering, e.g. - S6G for an M6 Stud. Fire Rated End Fixings are only available with the Trapeze Plus FR.

3 CHOOSE YOUR WIRE LENGTH

1M

2M

3M

4M

5M

10M

Enter your unique product code (e.g. **XP2-LG-4M**):

PRODUCT

END FIXING

WIRE LENGTH

For more available End Fixings and further product information please call **0800 0184 264** or visit our website www.gripple.com for further details.

Brackets & Accessories

A variety of accessories are available increasing versatility and ease of installation.

Universal Bracket

- Can be bolted directly to soffit or wall, or suspended from the soffit using threaded rod or Gripple Hanger e.g. Trapeze
- Eliminates the need for cutting channel on site
- Integrates with Trapeze No.2 and Y-Fit

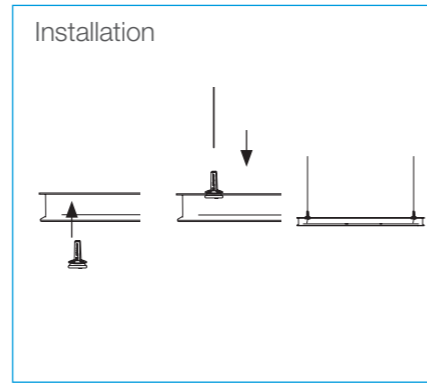
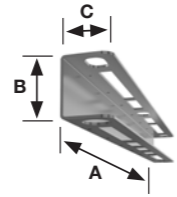

3:1 Safety rating

Product code	A (mm)	B (mm)	C (mm)	Max. SWL (kg) Between Fixings	Quantity
PB230	230	43	35	90	10
PB380	380	43	35	90	10
PB640	640	43	35	90	10
PB1020	1020	43	35	90	10
PB1200	1200	43	35	90	10

G-Bracket

- Purpose made for cable tray and basket
- Brackets can be easily joined together either vertically or horizontally to create a double fixing
- Ideal for use with the Y-Fit and Y-Fit Accessory (page 12)

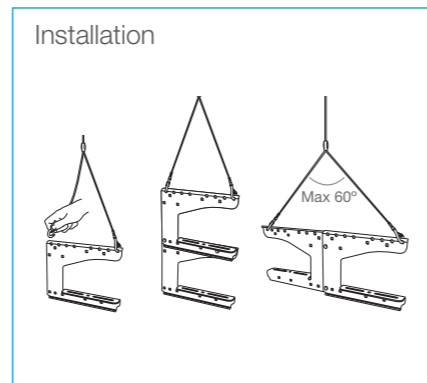
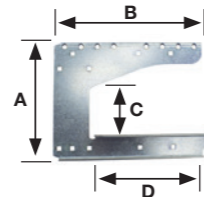

3:1 Safety rating

Product code	A (mm)	B (mm)	C (mm)	D (mm)	Max. SWL (kg)	Quantity
G-BRACKET-100	200	188	110	125	30	10
G-BRACKET-200	200	263	110	200	60	10
G-BRACKET-300	202	389	110	325	60	10
G-BRACKET-400	202	489	100	425	60	10

G-Spacer

- Joins two G-Brackets together, either vertically or horizontally allowing a central gap (max. 300 mm)
- Links different sizes of G-Bracket together
- Adjustable

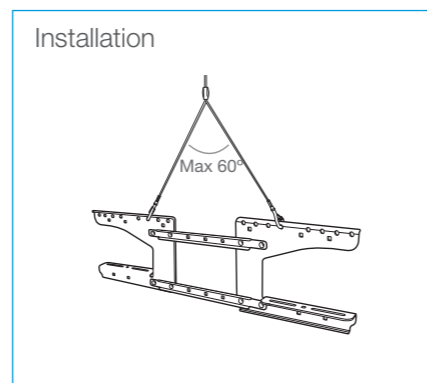
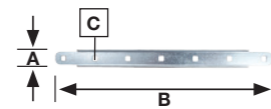

3:1 Safety rating

Product code	A (mm)	B (mm)	C (mm)	Quantity
G-SPACER	26	325	7x7	10

Catenary Wall Bracket

- 100 mm x 100 mm back plate for concrete walls and wooden beams
- 4 x 11 mm diameter mounting holes
- 65 mm hole spacing
- 9 mm ring for easy wire rope attachment
- Zinc plated finish (minimum 5 µ)

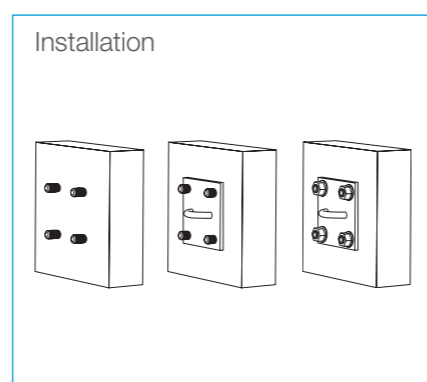
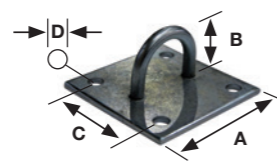

3:1 Safety rating

Product code	A (mm)	B (mm)	C (mm)	D (mm)	Max. SWL (kg)	Quantity
CAT-BRACKET-100	100	45	65	11	340	10



GF Bracket

Ideal for clamping onto an I-Beam when it is not possible to loop around with catenary wire, or when the height of the beam is too great.

Product code:
I-beam 6/13 mm: GF12-EYENUT
I-beam 8/16 mm: GF16-EYENUT-12
I-beam 10/19 mm: GF20-EYENUT-12



Beam & Purlin Clips

Available in a variety of sizes and models for attachment to beams and purlins. Contact us for sizing and product code options.



Spring Clip

The Spring clip is ideal for fixing to suspended services with 6 mm to 8 mm holes.

Product code:
CLIP-SPG-68



Twister

Aesthetic finish keeps tail wires neat and tidy. For use with 2 mm / 3 mm wire.

Product code:
TWIST-10BB



Cable Basket Adapter

Designed for use with the Trapeze No.2 to suspend cable baskets up to 6 mm wire diameter. Ideal for quick and easy installation of multi-tiered cable baskets.

Product code:
TZ2-ADP-CB6



Tensioning Tool

For use with 6 mm Catenary Kits. Tensions wire easily (up to 100 kg).

Product code:
CTI-6MM-TOOL

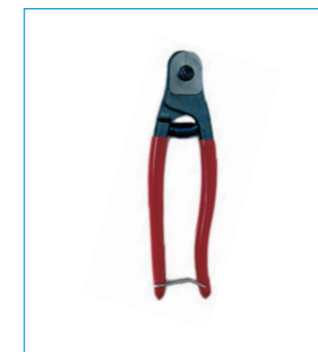

Wire Cutters

Purpose made for 4 mm wire. For use when terminating wire lengths.

Product code:
CUTTER-GRIPPLE



Thru-In-1®

Patented SDS+ drill bit and sleeve technology that simplifies the passing of cable or piping through cavity walls. Available in 22 mm and 28 mm starter packs.

Product code:
T11-22-STARTER
T11-28-STARTER

Trapeze Accessories

Trapeze No. 2, 3 & 4

Combine Trapeze as an accessory with any Trapeze kit for multi-tiered installations.

Product code:
TRAPEZE-NO2
TRAPEZE-NO3
TRAPEZE-NO4



Trapeze Plus No. 2, 3 & 4

Combine Trapeze Plus as an accessory with any Trapeze kit for multi-tiered installations. Load rating of 45-225 kg with a 3:1 safety factor.

Product code:
TRAPEZE-PLUS-NO2
TRAPEZE-PLUS-NO3
TRAPEZE-PLUS-NO4



Black Line

Gripple's ready-to-use suspension kits now come with the option of a black finish to further enhance the aesthetic appeal of the range.

The slim and unobtrusive aesthetics of Gripple's wire suspension system have always proved perfectly suited to the design of many modern buildings where building services in the roof space are left exposed and visible.



Key Recommendations

Failure to comply with these recommendations may result in product malfunction and possible damage to property or person and will invalidate the Gripple guarantee. Gripple products are guaranteed to be free from defects in materials and workmanship in accordance with our terms and conditions. No other warranty, whether express or implied, including any warranty of merchantability or fitness for purpose shall exist in connection with the sale or use of any Gripple product.

Full technical information and installation instructions should be obtained directly from Gripple Limited, Gripple Europe or Gripple Inc., any regional Gripple office, or via the website www.gripple.com.

Please adhere to the following key recommendations:



Loads

Always operate the product within its stated safe working load range.



Wire Rope

Always use the fastener supplied and specified wire rope. Never use on coated wire rope or other rope. Trim any damaged filaments with the wire cutter before use.



Lifting

Do not use for lifting, either by crane or as part of a pulley system. Suspend static loads only.



Environment

Do not use in chlorinated or chemically corrosive atmospheres. Standard hangers are for use in dry and air conditioned environments only. Stainless steel hangers should be considered for high to saturated humid environments after validation by a competent person. Not suitable for swimming pools.



Installation

Do not walk or stand on the Gripple product installation unless expressly designed for this purpose.



Impact

If there is potential for impact on the wire rope suspension or suspended services, seek advice from Gripple Ltd. Technical Services prior to installation.



Painting

Do not paint the hanger prior to installation. Ensure that the hanger is in its final position prior to applying any paint to the wire rope assembly. Do not move the fastener after painting.



Hanging at an Angle to Vertical

Ensure that the load calculation considers the effect of 'side load'. For example, at an angle of 60° to vertical the SWL is effectively reduced by 50%



Lubrication

Do not apply oil or any other lubricant to the hanger or any other part of the assembly.



Joining

Never join two ends together in-line.



Ducting: When installing included angle teardrop hangers on round/spiral ducting or pipes, the final included angle of the assembly should not exceed 60°.

Y-Fit: Legs on Y-Fit not to be installed greater than 60°.

Quality & Approval

Gripple UK is ISO 9001:2008 and ISO 14001 certified. Gripple products meet the highest standards of quality with lowest environmental impact.



Gripple's policy is one of continuous development and innovation. We therefore reserve the right to alter specifications, etc. without notice.

www.gripple.com

info@gripple.com



Gripple Ltd (Headquarters)

The Old West Gun Works
Savile Street East
Sheffield S4 7UQ
UK

T | +44 (0) 800 018 4264

F | +44 (0)114 275 1155

E | info@gripple.com

Gripple Inc

1611 Emily Lane
Aurora
IL 60502
USA

T | +1 866 474 7753

F | +1 800 654 0689

E | usinfo@gripple.com

Gripple Europe SARL

1, rue du commerce
BP 37
67211 Obernai Cedex
France

T | +33 (0)3 88 95 44 95

F | +33 (0)3 88 95 08 78

E | frinfo@gripple.com

Gripple India

B 95/2
Naraina Industrial Area
Phase I
New Delhi-110028

T | +91 11-40582703

F | +91 11-40582703

E | ininfo@gripple.com

WE ARE SOCIAL
FOLLOW OUR UPDATES



For details please visit www.gripple.com or call our Technical Team on 0800 018 4264

