



Transgulf Cement Products L.L.C.

عبر الخليج للمنتجات الإسمنتية ذ.م.م.



PRODUCT CATALOGUE

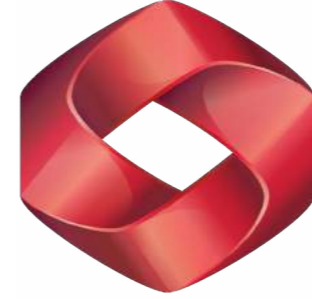

Transgulf Cement Products L.L.C.
عبر الخليج للمنتجات الإسمنتية ذ.م.م.

















PRODUCT CATALOGUE 2014

Pavers | Kerbs | Tiles | Masonry Blocks | Precast

CONTENTS

ABOUT US	8 - 9
COLOURS	10 - 11
FINISHES	12 - 13

1 PAVERS

1.1	Sienna®		16 - 19
1.2	La Lenia		20 - 21
1.3	Viva Classico®		22 - 23
1.4	Flair®		24 - 25
1.5	Rusto®		26 - 27
1.6	Antique®		27 - 28
1.7	Amwaj®		29 - 30
1.8	Aura®		30 - 31
1.9	Venus®		32 - 33
1.10	Ladana®		34 - 35
1.11	Square®		36 - 37
1.12	La Plaza®		37 - 38
1.13	Octapave		39 - 40
1.14	Uni Paver		41 - 42
1.15	Behaton		43 - 44
1.16	Honeycomb®		45 - 46
1.17	Monaco		47 - 48
1.18	Rectangular®		49 - 50
1.19	Grasscrete		51 - 52
1.20	La Rambla®		53 - 54

2 KERBS

2.1	Heel Kerb	60 - 61
2.2	Sienna® Kerb	62 - 63
2.3	Half Battered Kerb	64 - 65
2.4	Flush Kerb	66 - 67
2.5	Bullnose Kerb	68 - 69
2.6	Gutter Kerb	70 - 71
2.7	Barrier Kerb	72 - 73
2.8	Rollover Kerb®	74 - 75
2.9	Channel Kerb	76 - 77
2.10	Wheel Stopper	78 - 79

3 TILES

82 - 85

4 MASONRY BLOCKS

4.1	Hollow Block	88 - 89
4.2	Solid Block	88 - 89
4.3	Hourdi Block	88 - 89
4.4	Thermo Block	88 - 89

Retaining Wall Systems

4.5	Geoblock	90 - 91
4.6	Dwell Block	90 - 91

5 PRECAST

94 - 97

6 IMPORTANT INFORMATION

100 - 101

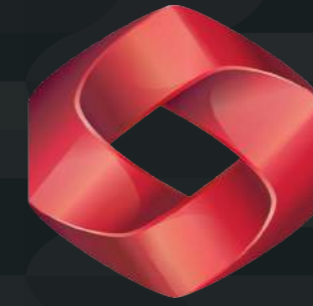

Transgulf Cement Products L.L.C.
عبر الخليج للمنتجات الإسمنتية ذ.م.م.

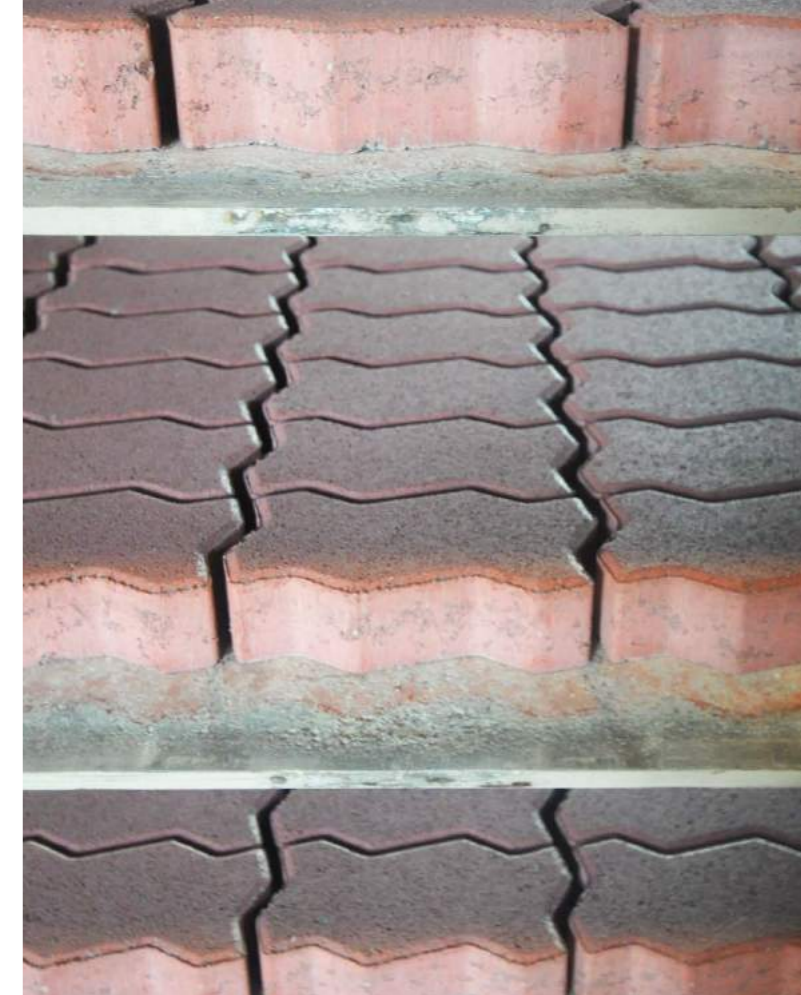

About us

Founded in 1996, Transgulf Cement Products is one of the leading suppliers of concrete products in the GCC region. Strategically located in the Jebel Ali Industrial Area, we cater to the product requirements of a range of clientele, having built up a solid, unshakeable reputation in the industry over the last decade. Constant innovation and exceptional customer service lie at the heart of our company values, and these founding principles have marked every venture of Transgulf, making us one of the leading names for concrete products in the region.

Symbolic of our founding principles, our products serve to strengthen, enhance and toughen the landscape where they are applied. Equipped with state-of-the-art technology, our plant operates with seamless efficiency and productivity, 24 hours a day. In addition, we take pride in our in-house research and development wing, where our experts are committed to the development of innovations in engineering and manufacturing processes to make our products one of the best in the industry.

At Transgulf Cement Products, our first commitment is to provide quality products through prompt delivery, followed by active involvement until project completion. Our consultancy team of experienced professionals are always ready to provide you with valuable assistance in selecting a product, pattern, colour or design. Our efficient after-sales service team makes regular visits to construction sites to ensure smooth co-ordination between project requirements and product supply. Our growing list of clients stands testament to Transgulf's standards of quality and excellence.

Our wide range of concrete products are available in a multitude of colours, patterns and designs to suit all types of architectural projects. For over a decade, we have been providing clients quality products for their every need. No matter what your requirements - be it a villa or building complex, a warehouse or public park - our team of experienced professionals will provide you with all the assistance needed in making the right selection for your particular requirements.

“Two values lie at the heart of Transgulf's operations in the UAE: exceptional customer service and constant innovation. These founding principles, which have guided us from the beginning, have been the key to our success.”

Board of Directors



Our stringent in-house quality standards have won the company an ISO 9001 Certification, a milestone that marks the highest standards of excellence in industrial practice. Our products also meet the standards stipulated by all the Emirates, various government organisations, BS specifications and GCC countries.

At Transgulf, we constantly strive to achieve the following objectives:

- To live upto our commitment to customers, products and processes, with the aim of continuously improving the effectiveness of the QMS
- To maintain Quality Consistency by continuously monitoring and strictly following procedures
- To provide the best quality products, and always on time
- To adapt and modernize our technological processes to suit changing needs and standards
- To always maintain a clean and safe working environment for our employees
- To provide proper training and motivation to our employees, while recognizing that they are the key to achieving customer satisfaction

Colours

All our products, including pavers, kerbs and tiles are available in a wide range of colours to suit any of your design requirements. Complete customisation is also possible to suit your particular project colour scheme. The list of colours available at Transgulf is listed below.

(Please note that the exact colour of a product may vary according to chosen product and texture.)



Finishes

A complete list of available finishes for pavers, tiles and kerbstones is detailed below. Recommended finishes for each series are suggested on individual product pages.



1 Shotblast

In this finish, the top surface is blasted with miniature steel balls to remove fine mortar, and reveal the natural chips and aggregates of the paver, tile or kerbstone.



2 Transgulf Eco-Pave

An environment-friendly option, Transgulf's exclusive Eco-Pave finish is surface treated to prevent water from seeping through, thus preserving the original visual appearance of the concrete over time.

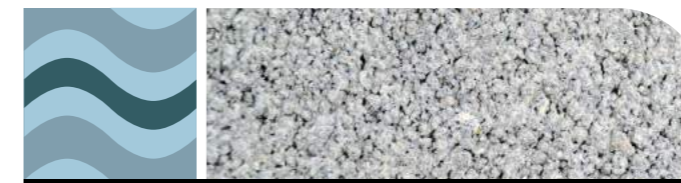

11 Smooth

This is a standard finish which has a smooth, textured effect. Smooth finish does not expose any aggregate or chips.



12 Exfoliated

Exfoliated finish is a special process where the product skin is removed in flakes without exposing too much of aggregate matrix, resulting in a textured surface that is soft to the touch.



3 Curling®

Using an automatic German machine, the surface of fully cured products are curled using a special carborundum brush to create a smooth, silken finish.



4 Transgulf Eco-Flow

Eco-flow is a permeable paving system that boosts urban drainage. It prevents the flooding of paved areas, while collecting and filtering rain water for later use.



13 Tumbled

Tumbled finish involves an automatic process where cured product edges are tumbled to give an old, distressed look and feel to products. Tumbled finish is often used to create an old-world charm to the landscape.



14 Toro

Toro refers to our special range of round edged products, created with a specially designed Italian machine. The Toro rounded edge is usually used to protect vulnerable areas.



5 Washed

High-pressured jets of water clean the top layer prior to hardening of the surface, resulting in a unique, textured surface that exposes the natural aggregates of the surface.



6 Bush Hammered

Employing an automatic German machine, the surface is pummelled by pyramidal chisels mounted on a hammer to create a roughened, natural looking surface.



15 Riven Finish

A special embossed effect with an undulating surface pattern, the Riven finish boasts of an irregular finish with a rough, granular surface texture.



16 Multi Color

Using Italian technology, two or more colours are blended in a single product to create a custom mix of hues that give any paver or kerb a natural, unique look.

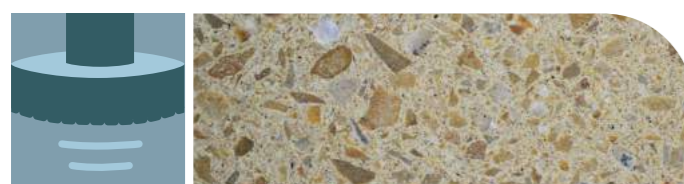

7 Honed

Carborundum stone grinding machines are used to grind the surface with the purpose of exposing the natural brightness and shapes of the colored aggregates and chips.

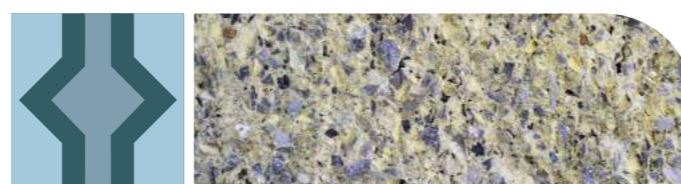

8 Split Finish

The surface of the product is split in two to expose its natural uneven structure. Split finish is often used for applications on custom designed blocks and steps.



17 Diamond Cut

A specialized machine cuts the top surface of the product with diamond blades to reveal the aggregates' natural beauty, resulting in a uniform, smooth surface.



18 Pimple

As the name suggests, this finish has small pimple-like elevations on its surface resulting in a consistent dotted surface pattern that is rough to the touch.



9 Embossed

Also known as Antique, this finish takes a step back in time, boasting a irregular and rough structured surface. Embossed finish offers good protection against slipping.



10 Normal

Normal finish is the standard, default finish for all concrete pavers made by Transgulf. This finish is also called Factory finish.



19 Tactile

Also known as detectable warning surface, Tactile is commonly used on footpaths, train stations and bus stations to assist the visually challenged.



20 Machine Laying

All products in this range can be laid by machine in pre-determined layout patterns. Machine laying is ideal for use in large areas like container terminals and warehouses.



1 PAVERS

Transgulf manufactures a wide range of concrete pavers with different attractive textures and colors to match your outdoor living space in the comfort of your own design. A variety of color choices and finishes allow you to have unlimited possibilities to develop the natural beauty of your surroundings.

Transgulf's paving stones are versatile, aesthetically attractive to meet the demand of any type of landscape architect and cost effective.

Transgulf's paving comply with BS 6717 & ASTM C 140.



1.1

PAVERS Sienna®

- A modern, versatile paving solution that works best when highlighted with contrasting colours and textures.
- Suitable for a wide range of environments including pathways, patios and streetscapes.

One of Transgulf's most popular ranges, Sienna is a multi-faceted paving solution suitable for driveways, walkways, patios and everything in between. The versatility of Sienna truly comes to the fore when colours and finishes are mixed together to create a limitless array of design possibilities that attract the human eye with ease.

Whether a simple residential setting or a larger public area, Sienna is a popular solution for most paving requirements. With a design that's modern and contemporary, it offers a clean, international look to any commercial or residential environment.

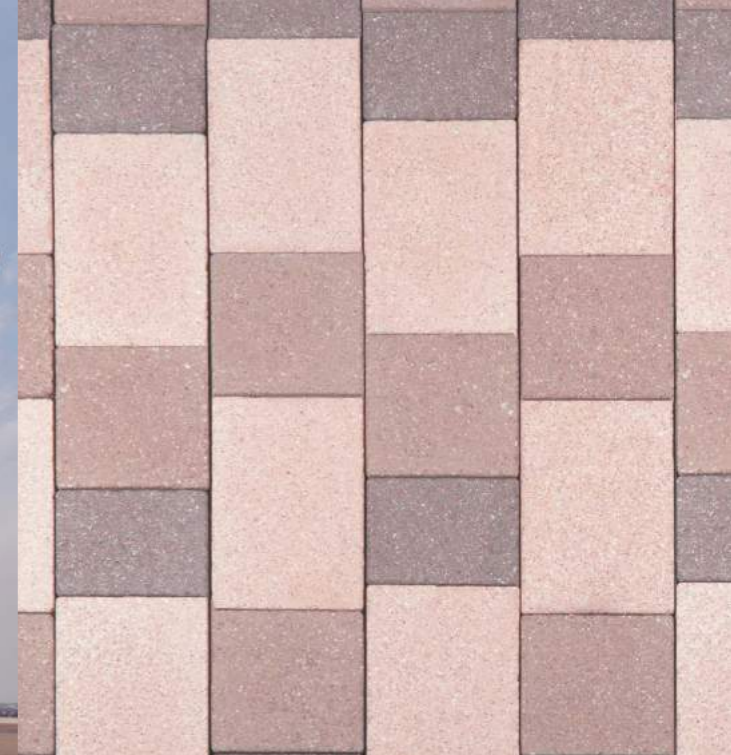
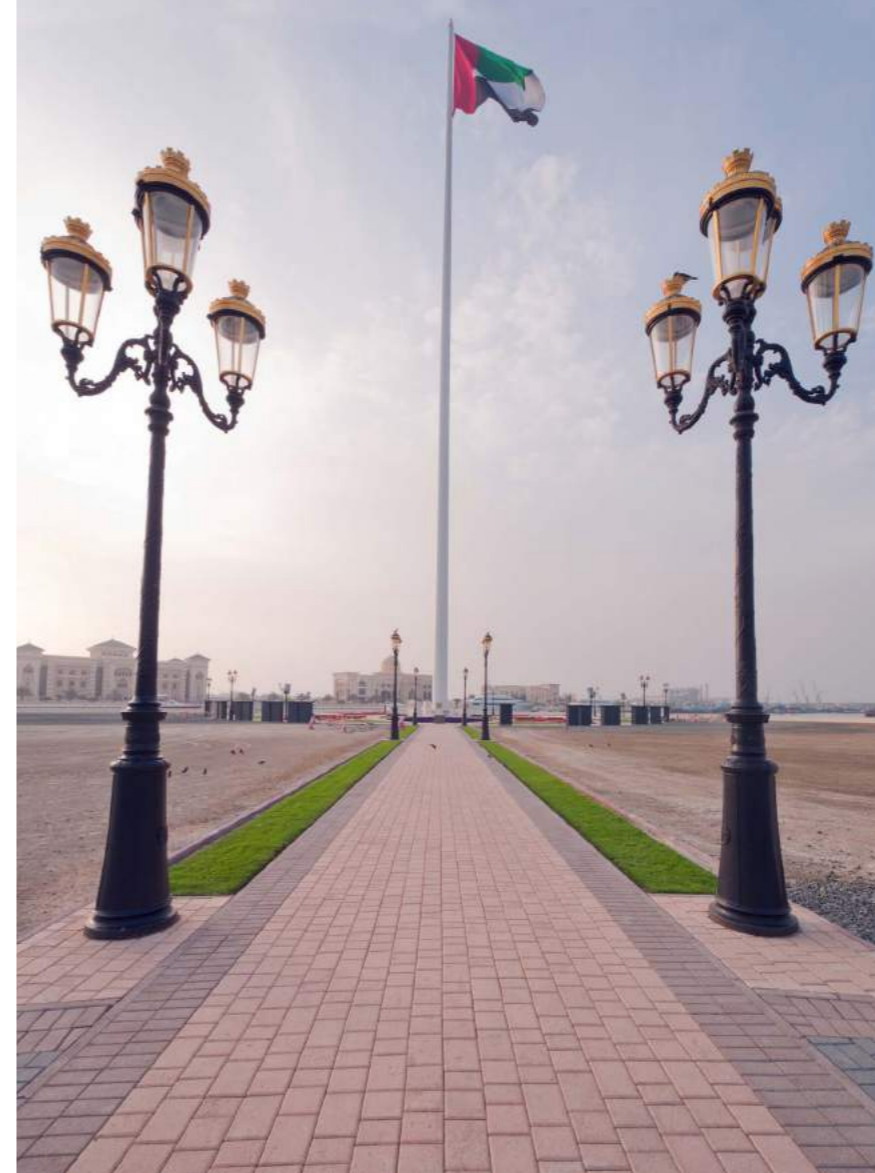

Flag, Sharjah

The public park at Sharjah welcomes people from all walks of life, and its centerpiece is this imposing flag hoisting pole. Transgulf's Sienna range is the paver of choice for the walkways and pathways surrounding the area resulting in a modern, utilitarian look.



Miracle Gardens, Dubai

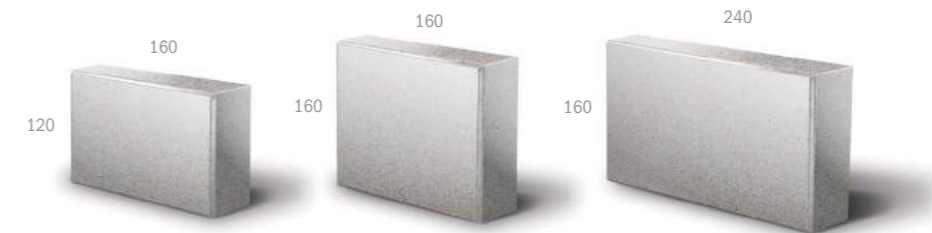

Item	Sienna							
	160x120		160x160		240x160		240x160/120	
Length(mm)	160		160		240		240/160/120	
Width(mm)	120		160		160		160	
Thickness(mm)	60	80	60	80	60	80	60	80
Weight of block (kg)	2.7	3.6	3.6	4.9	5.5	7.3	5.5/3.6/2.7	7.3/4.9/3.6
Blocks /m ²	52	52	39	39	26	26	36.48	36.48
Blocks/bundle	540	540	378	378	270	270	378	378
Square meter/bundle	10.36	10.36	9.67	9.67	10.36	10.36	10.36	10.36

RECOMMENDED FINISHES



1.1

PAVERS Sienna®

- A good alternative to the conventional rectangular paver.

Also known as Tegula, it is an alternative to the traditional rectangular paver. With a good resistance to load, pavers are commonly used for walkways and pathways that witness heavy pedestrian and light motor traffic.

Easy to pack and ship like the rectangular pavers, this shape offers even more flexibility with regard to design as they can be used in combination with other paver shapes to create a variety of interesting patterns. From conservatories to courtyards, sienna is a beautiful and practical paving solution for most paving needs.



📍 Sport City, Dubai

The usage of this sienna paver allows for alternative styles for pathways and walkways within the newly developed residential area.

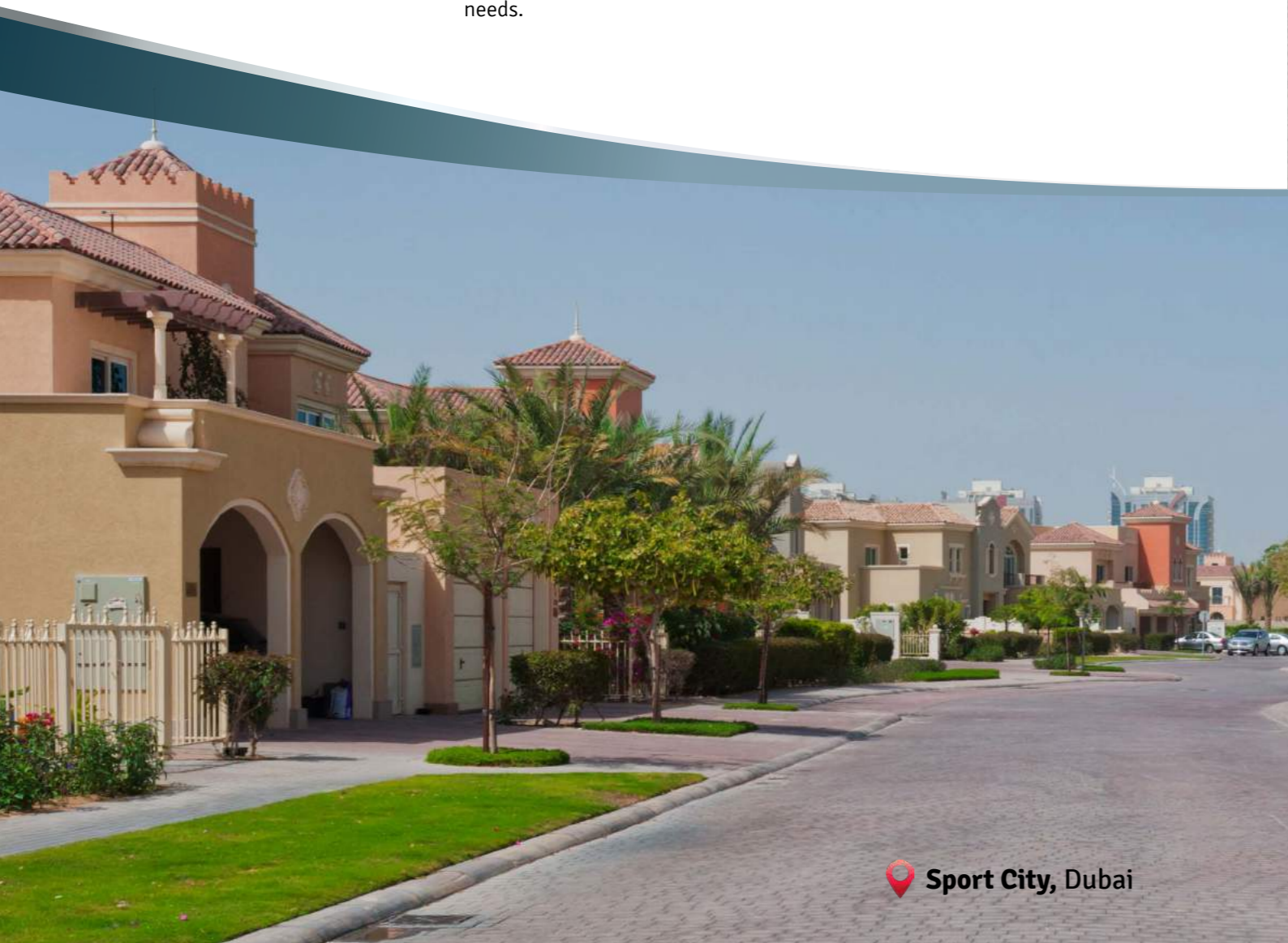

📍 Sport City, Dubai

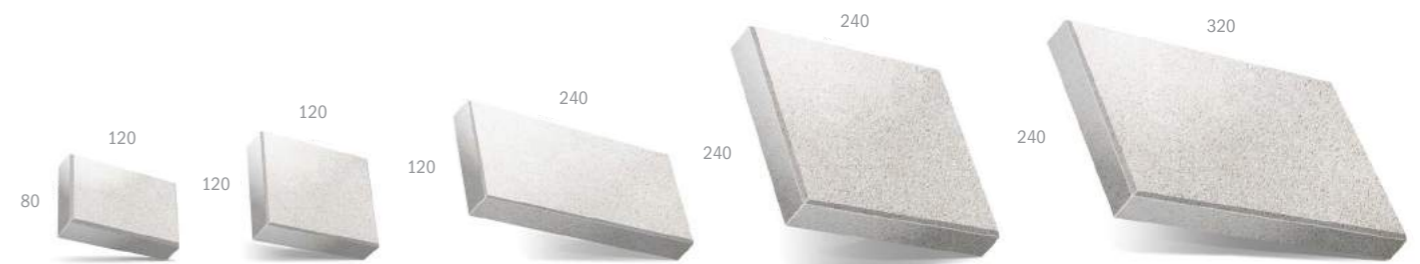

Item	Sienna 2				
Length(mm)	120	120	240	240	320
Width(mm)	80	120	120	240	240
Thickness(mm)	80	80	80	80	80
Weight of block (kg)	1.85	2.76	5.5	11	14.7
Blocks /m ²	104.25	69.5	34.73	17.36	13
Blocks/bundle	1008	720	360	135	108
Square meter/bundle	9.67	10.36	10.36	7.77	8.29

RECOMMENDED FINISHES

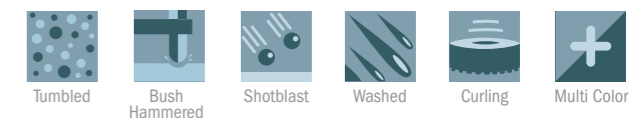

1.2

PAVERS La Lenia

- Evokes a sense of strength and dependability with its large, bold forms.
- Its design is always in perfect harmony with modern architecture.

Make a stunning statement with the bold, rectangular shapes of La Lenia, a perfect addition to any modern outdoor space. A combined range of concrete block and textured flag paving, La Lenia evokes a sense of strength, stability and dependability with its large shapes and bold form.

La Lenia is available in a variety of colours and textures, and is a perfect fit for contemporary structures due to its straight lines and sharp angles which are always in harmony with modern architecture.

Item	La Lenia									
	300		300		400		600		600	
Length(mm)	300		300		400		600		600	
Width(mm)	100		150		200		200		300	
Thickness(mm)	60	80	80	60	80	60	80	60	60	80
Weight of block (kg)	4.32	5.76	8.5	8.64	11.52	11.52	15.36	12.96	25.92	34.56
Blocks /m ²	33.33	33.33	22.22	16.66	16.66	12.5	12.5	11.11	5.55	5.55
Blocks/bundle	288	288	216	180	180	135	135	54	54	36
Square meter/bundle	8.64	8.64	9.72	10.8	10.8	10.8	10.8	9.72	9.72	6.48

RECOMMENDED FINISHES



Jumeirah Village, Dubai



Miracle Gardens, Dubai

1.3

PAVERS Viva Classico®

- Inspired by old European architecture, Viva's distinctive fan patterns are a signature style.
- With friendly curves and a rustic look, they are extremely popular for use in residential villas, pool surrounds and patios.

Inspired by ancient European architecture, the distinctive fan pattern of Viva Classico employs the attractive circles and sweeping curves of ancient times and adapts them to a modern setting. One of the most beautiful paving patterns around, the Viva pattern is especially favoured in residential projects as their friendly curves and rustic look add a sense of intimacy to any home or apartment complex. The weathered and elegant look of Viva makes it a popular option for villas, patios and pool surrounds as well.

The Viva series offers tremendous flexibility with respect to the size of the fan and the colour of the pavers, thus offering a limitless array of interesting laying patterns.



Item	Viva Classico
Length(mm)	Varies
Width(mm)	Varies
Thickness(mm)	80
Weight of block (kg)	Varies
Blocks /m ²	106.67
Blocks/bundle	576
Square meter/bundle	5.4

RECOMMENDED FINISHES

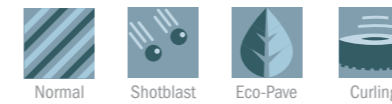

Burj Al Arab, Dubai

Creating a unique and attractive design around the Burj Al Arab, Transgulf's Viva range is used to stunning effect here, along with other paving ranges in a melange of styles and colours.



1.4

PAVERS Flair®

- Irregular shapes and rounded curves evoke a friendly, old-world feeling.
- Best suited for pedestrian walkways and pathways.

A simple, classic paving option that serves as an alternative to the straight, geometric lines commonly seen in interlocking pavers, the Flair range offers a more rustic charm to your paving needs. With gentle curves and irregular shapes, Flair takes its inspiration from nature, evoking long nostalgic walkways in the woods that hark back to a simpler time.

An ideal solution where a touch of the natural is needed, Flair is commonly used in contemporary landscapes that witness mainly pedestrian walkers. The Flair series also juxtaposes well against modern structures for a healthy contrast of the old and the new.



 Sport City, Dubai



(Irregular Shapes)

Item	Flair
Length(mm)	Irregular shape
Width(mm)	Irregular shape
Thickness(mm)	80
Weight of block (kg)	Varies
Blocks /m ²	71.8
Blocks/bundle	648
Square meter/bundle	9.02

RECOMMENDED FINISHES



1.5

PAVERS Rusto®

- Inspired by the look and feel of ancient Roman pathways
- Best suited for roads and pathways with light vehicular traffic

Influenced by the paved walkways of ancient Rome, the Rusto series is a departure from the clean-cut lines of more commonly used pavers. Emanating an old-world charm and timeless appeal, Rusto derives its name from the rustic aesthetic it has become synonymous with.

Rusto comprises three distinct shapes that can be laid combination with each other. The real beauty of Rusto lies in the visual movement its patterns create when used over large areas.



Item	Rusto
Length(mm)	210 / 150 / 90
Width(mm)	120
Thickness(mm)	80
Weight of block (kg)	4.6 / 3.3 / 1.9
Blocks /m ²	55.56
Blocks/bundle	540
Square meter/bundle	9.72

RECOMMENDED FINISHES

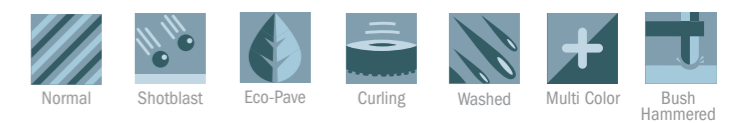

1.6

PAVERS Antique®

- Inspired by the look of traditional, aged stone pavings.
- Work well in projects that call for a mix of the modern and the traditional.

As the name suggests, Antique pavers take their inspiration from the allure of cobbled stone pathways and the charm of quaint, English cottages in the country. Emulating the natural beauty of stone pavers with an aged, traditional look, the Antique pavers are a perfect fit for any landscape application that calls for a mix of the old and the new.

By design, the Antique pavers add a sense of warmth and intimacy to any environment and help you recreate that ancient charm of times gone by in your contemporary landscaping designs. The quarry-fettled edges of Transgulf's Antique pavers only add further to its authentic, aged finish.

Item	Antique	
Length(mm)	196/140/109	196/140/109
Width(mm)	140	140
Thickness(mm)	60	80
Weight of block (kg)	3.9 / 2.8 / 2.2	5.2 / 3.7 / 2.9
Blocks /m ²	51	51
Blocks/bundle	378	378
Square meter/bundle	7.4	7.4

RECOMMENDED FINISHES

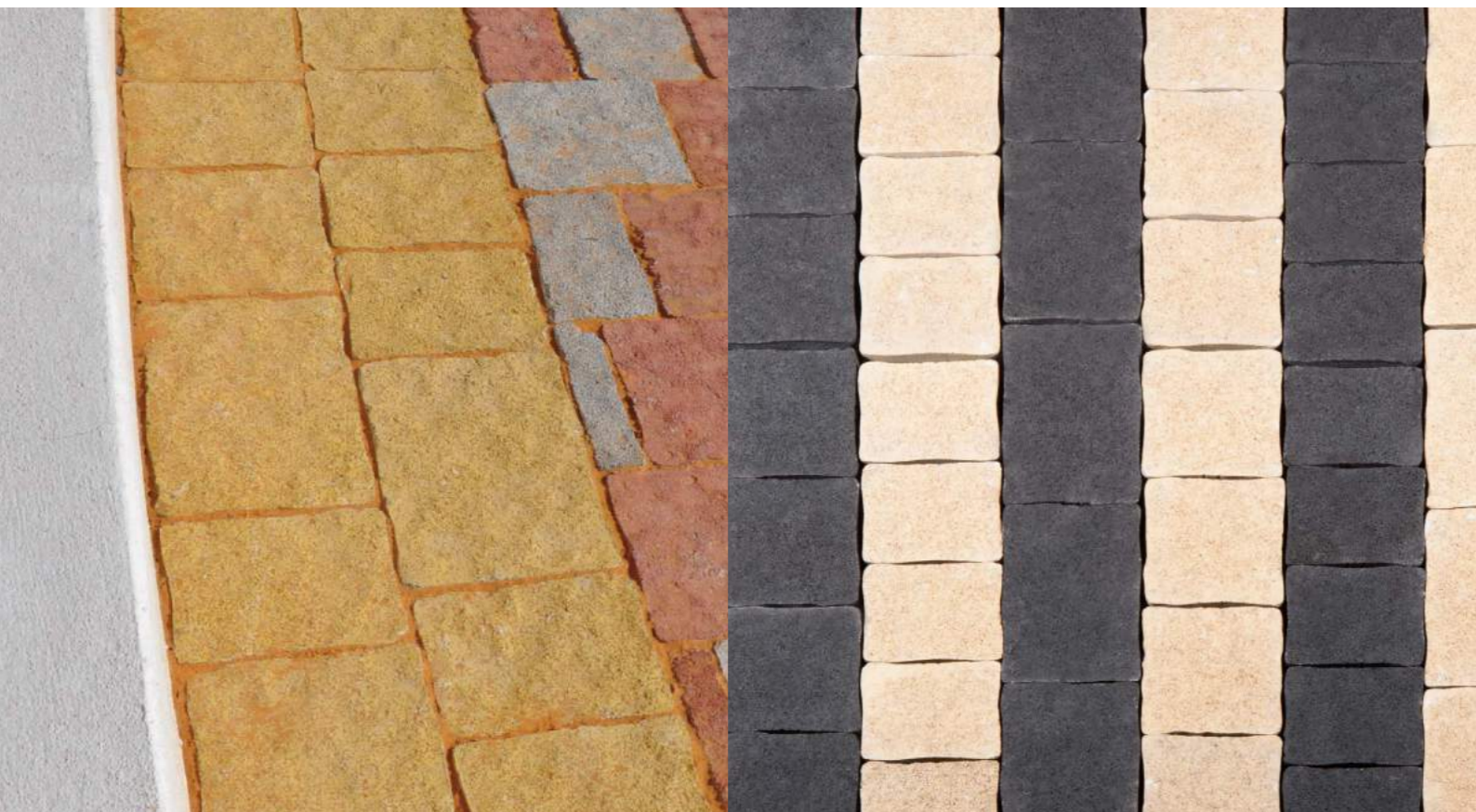
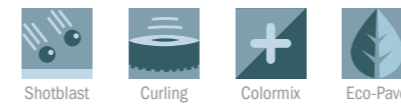

1.7

PAVERS Amwaj®

- Amwaj or 'waves' in Arabic, draws inspiration from the curvaceous form of water
- Best suited for a gentle pattern on patios, pathways and driveways

The undulating wave patterns of the Amwaj paver series conjure up images of the sea, the waves and all things tranquil. A refreshing departure from the straight lines and angular cuts of regular pavers, Amwaj takes its inspiration from the soothing curves of flowing water.

The pavers create a gentle wave-like effect on being laid and are commonly used in patios, driveways and walkways for a unique, soothing look. The Amwaj paving system is well suited to both single colour usage, as well as multiple colours.

Item	Amwaj	
Sides (mm)	200/210/320	
Thickness(mm)	60	80
Weight of block (kg)	8.3	10.3
Blocks /m ²	18	18
Blocks/bundle	144	144
Square meter/bundle	8	8

Item	Amwaj Starter
Sides (mm)	200/210/320
Thickness(mm)	60
Weight of block (kg)	8.3/7.2
Blocks /m ²	18.7
Blocks/bundle	144
Square meter/bundle	7.7

RECOMMENDED FINISHES

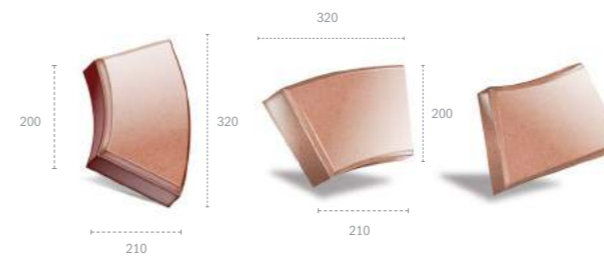

📍 Private Villa, Dubai

The soft curves of Amwaj make for a welcoming driveway at this private villa. Amwaj's curvaceous lines lends this design an air of intimacy and softness, making them a popular range for private villas and residential projects.

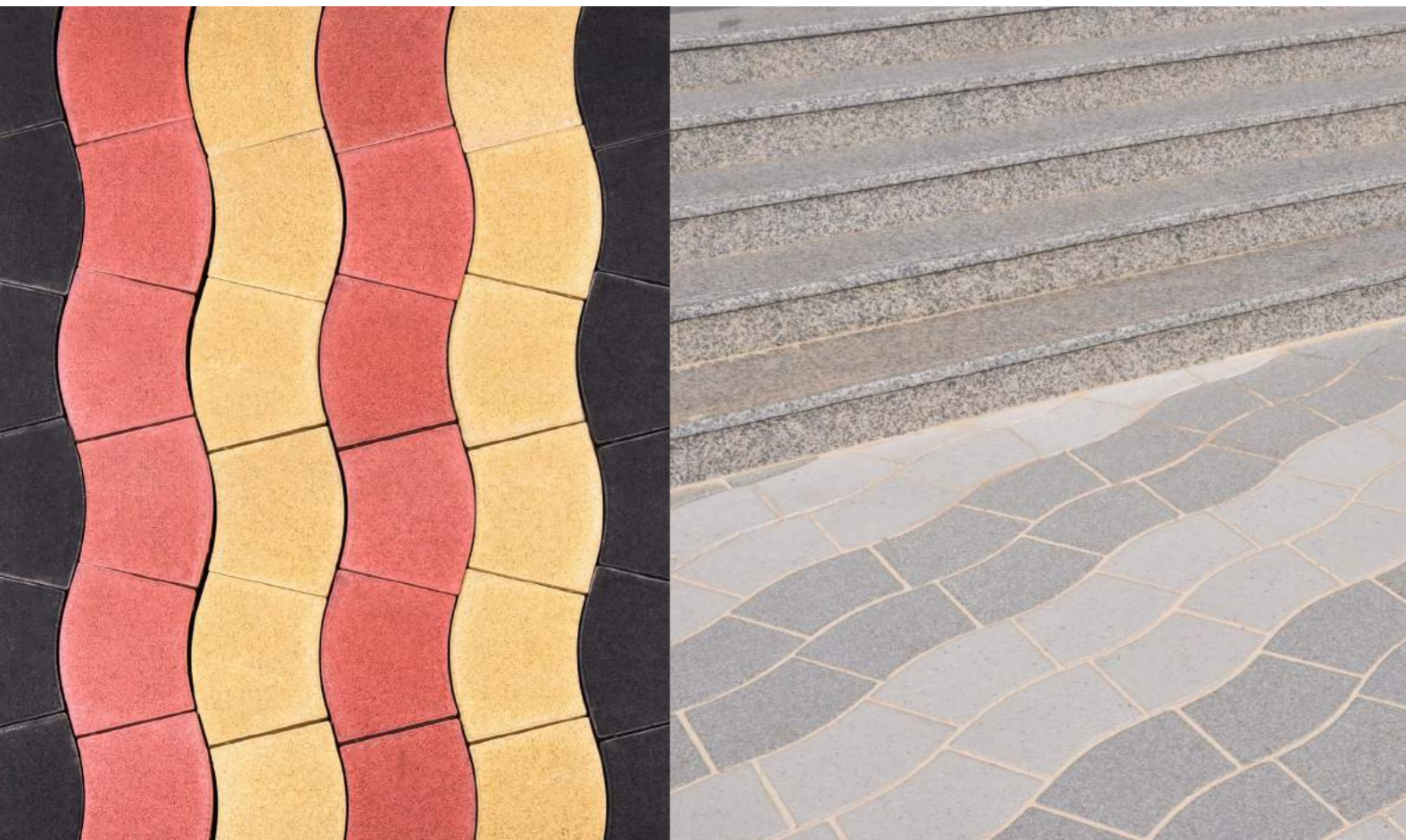

1.8

PAVERS Aura®

- Aura gets its name from its distinctive glint or shine
- Simple, modern classic with a wide variety of commercial and residential applications

Named for the unique glint that the pavers display, Aura is a modern, universal paving solution suitable for most residential and commercial projects. The visible glint or shine of the Aura pavers comes from a unique ingredient used exclusively during the manufacturing process.

A simple, modern classic, Aura comprises of three different shapes made more interesting by the application of various colours and finishes.



Rotana Hotel, Al Ain

Situated in the heart of Al Ain, Rotana is one of the few large hotels in the emirate. The hotel uses Aura pavers on walkways and driveways, right in front of the hotel, speaking for the product quality itself.



 Rotana Hotel, Al Ain



Item	Aura			
	280 / 225 / 150	280	150	
Length(mm)	280 / 225 / 150	280	150	
Width(mm)	225 / 140 / 140	225	140	
Thickness(mm)	60	80	60	80
Weight of block (kg)	9/4.5/3	12/6/4	9	4
Blocks /m ²	25.96	25.96	15.90	47.62
Blocks/bundle	270	270	144	432
Square meter/bundle	10.4	10.4	9.072	9.072

RECOMMENDED FINISHES

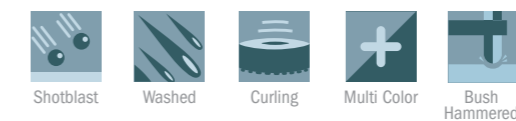

1.9

PAVERS Venus®

- Makes a bold statement exploiting geometric patterns and optical illusions
- Especially striking over large coverage areas, by drawing in the viewer's eye to the patterns

Taking its name from the mythical planet of the same name, the Venus series makes a bold statement with alluring patterns reminiscent of breathtaking perspectives and geometric illusions. The signature "diamond" shape of the Venus series lends itself beautifully to striking laying patterns, and is a visual play of sharp angles and optical illusions.

Choose the Venus series for a spectacular style that is sure to add a memorable and bold statement to your environment. Especially striking on installations over large areas, the Venus adds a new dimension and character to your paving like no other.

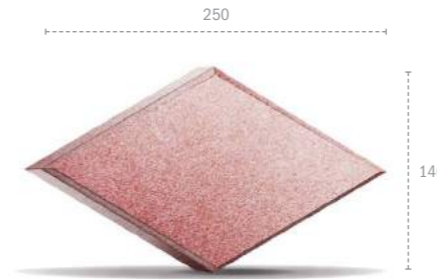

Item	Venus
Length(mm)	250
Width(mm)	140
Thickness(mm)	60
Weight of block (kg)	2.8
Blocks /m ²	51
Blocks/bundle	378
Square meter/bundle	7.41

RECOMMENDED FINISHES

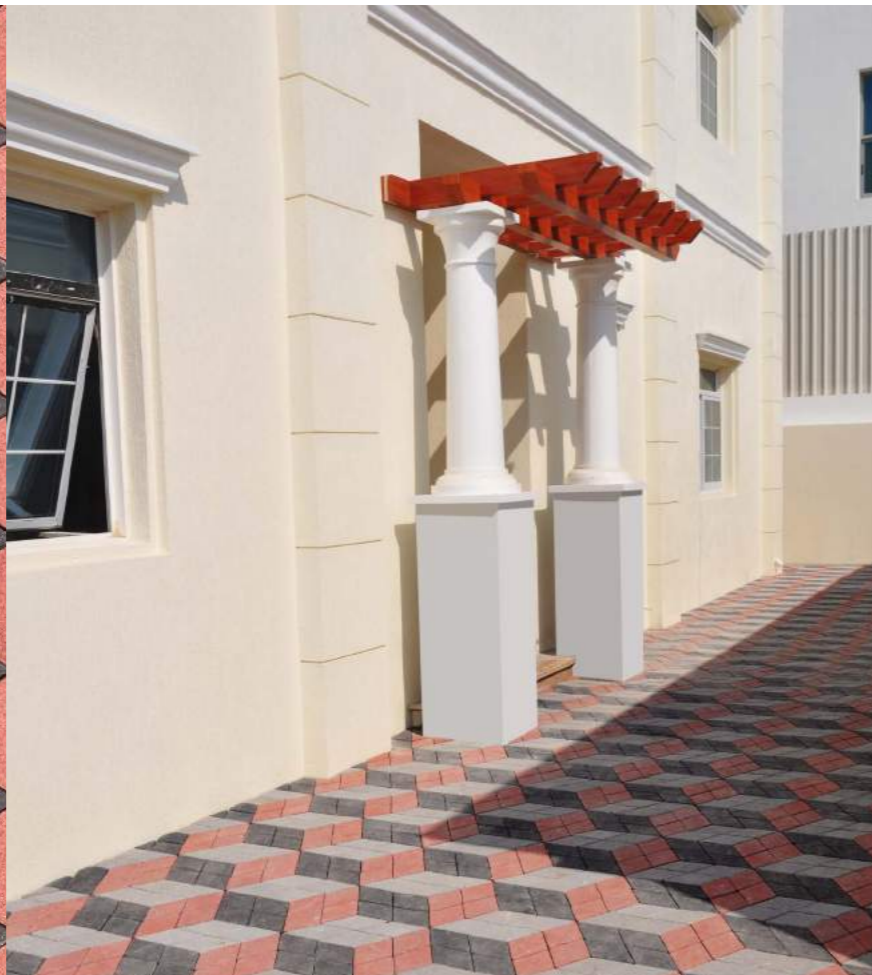

📍 Private Villa, Dubai

Create a dramatic, three dimensional effect for your landscaping project with the diamond shaped pattern of the Venus range. The hypnotic allure of Venus' shape is sure to make heads turn with its bold, geometric feel.

1.10

PAVERS Ladana®

- Provides the perfect counterfoil to the beauty of your main home or office
- Use solely or in combination with square and rectangular pavers
- Known for its subtle elegance, Ladana puts the spotlight on your main structure

The Ladana series is designed to blend in with your surroundings and let the light shine on the main architectural focus – be it your home, office or any other landscaping project. Enhance the visual grandeur of your home or office with Ladana as the perfect compliment to your project, and let the series work its magic as the pavers merge harmoniously with your environment.

Drawing upon the strength of conventional pavers, Ladana can be used in isolation or in tandem with Square and Rectangular pavers to create a range of subtle laying patterns. Ladana is especially popular for residential properties and add just that right hint of subtle elegance to your project.

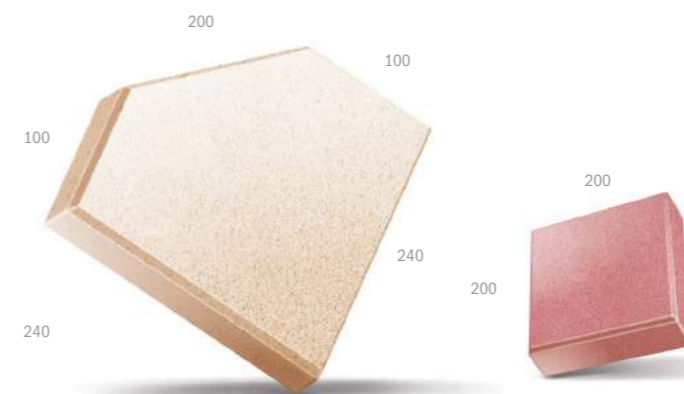
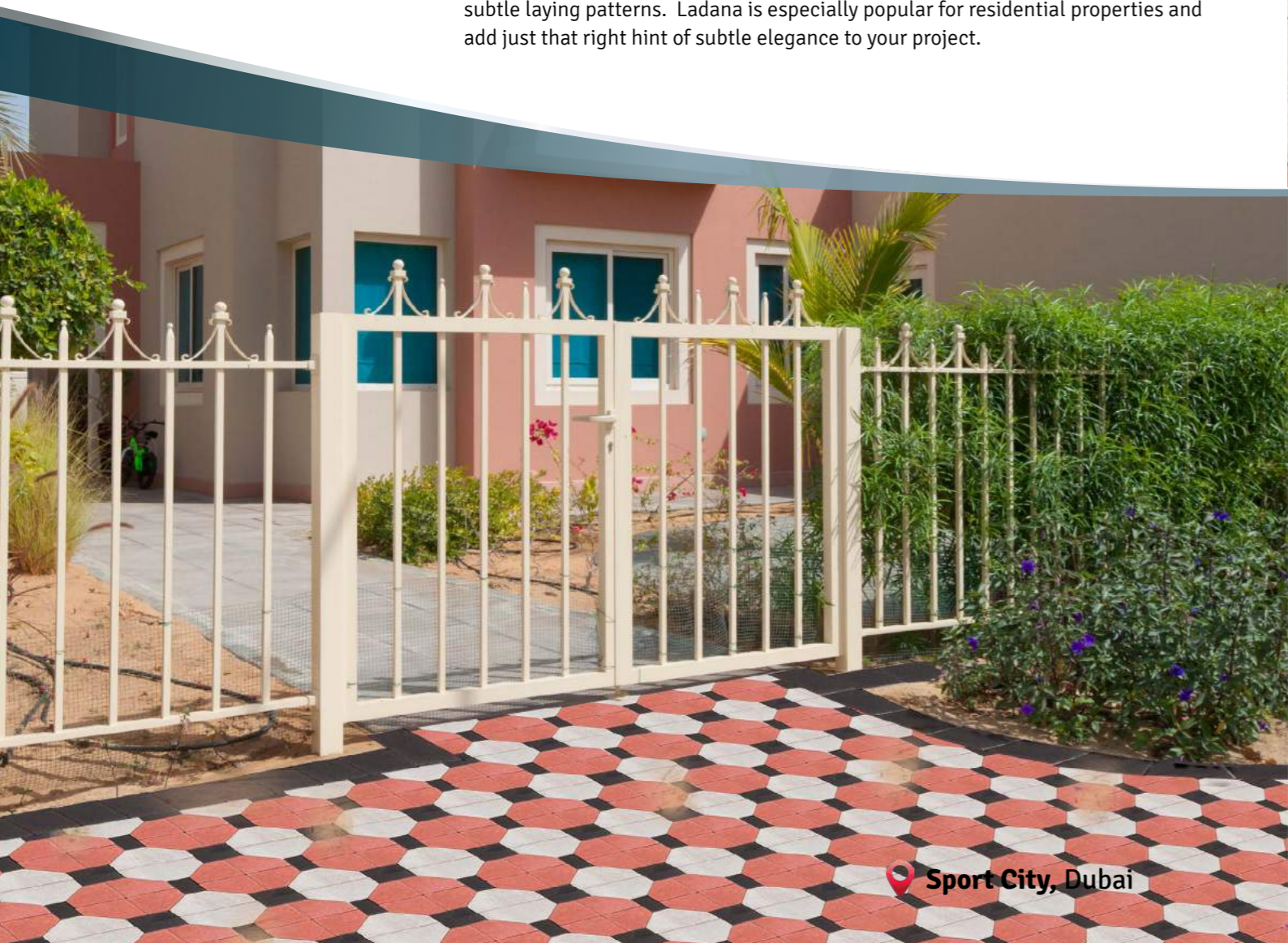
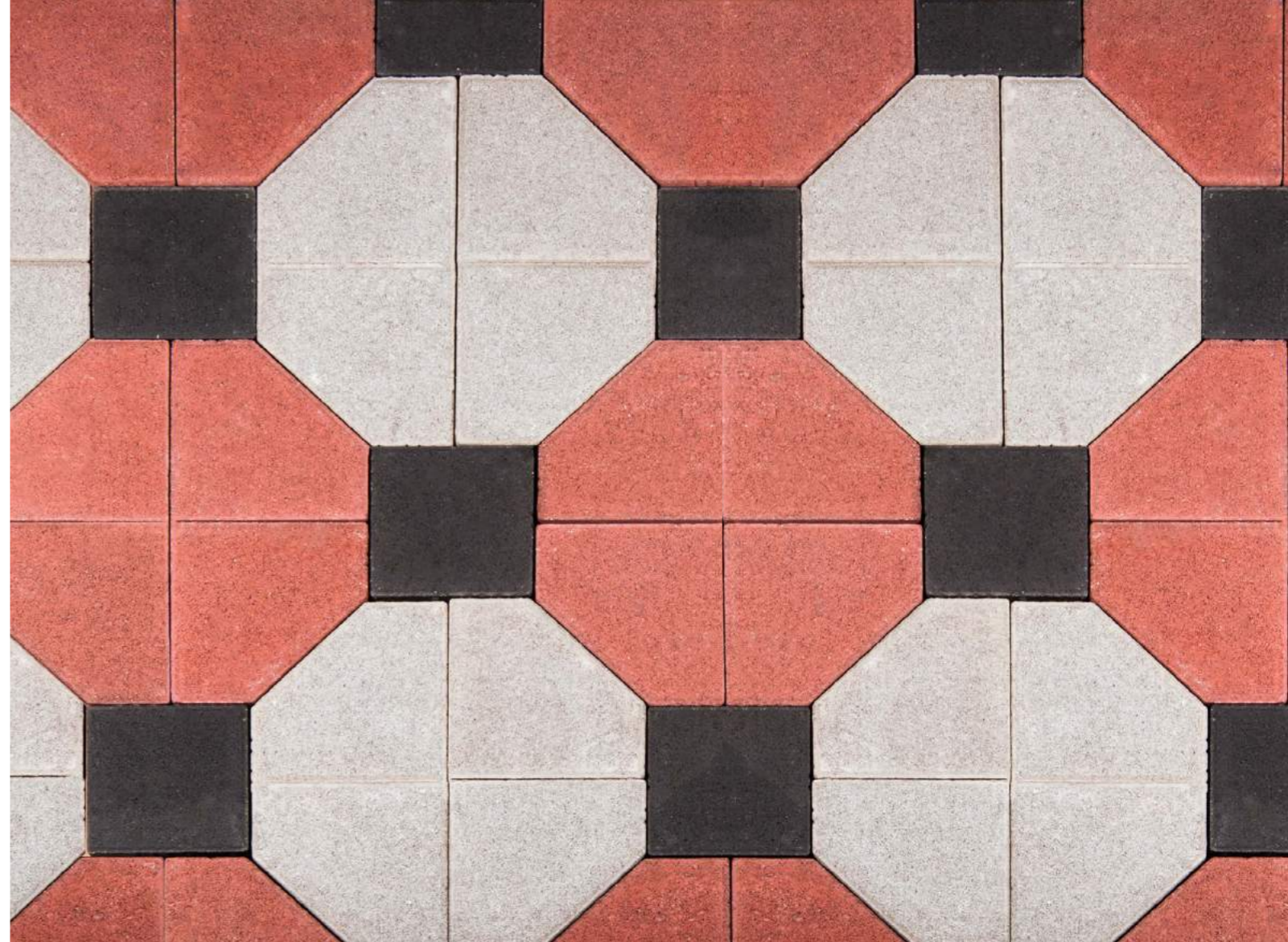

Item	Ladana
Length(mm)	240
Width(mm)	100/200
Thickness(mm)	60
Weight of block (kg)	6.8
Blocks /m ²	20.7
Blocks/bundle	135
Square meter/bundle	6.52

RECOMMENDED FINISHES



1.11

PAVERS Square®

- A good alternative to the conventional Rectangular paver.
- Can be used solely or in combination with other shapes such as Ladana or Hexagonal to create a range of unique design patterns.

A simple and popular paving solution, the Square paver is an economical paving range with a wide variety of applications. With a good resistance to load, Square pavers are commonly used for walkways and pathways that witness heavy pedestrian and light motor traffic.

Easy to pack and ship, the Square shape offers great flexibility in design as they can be used in combination with other paver shapes such as Ladana, Hexagonal and Rectangular to create a variety of interesting patterns. From conservatories to courtyards, the Square is a beautiful and practical paving solution for most paving needs.

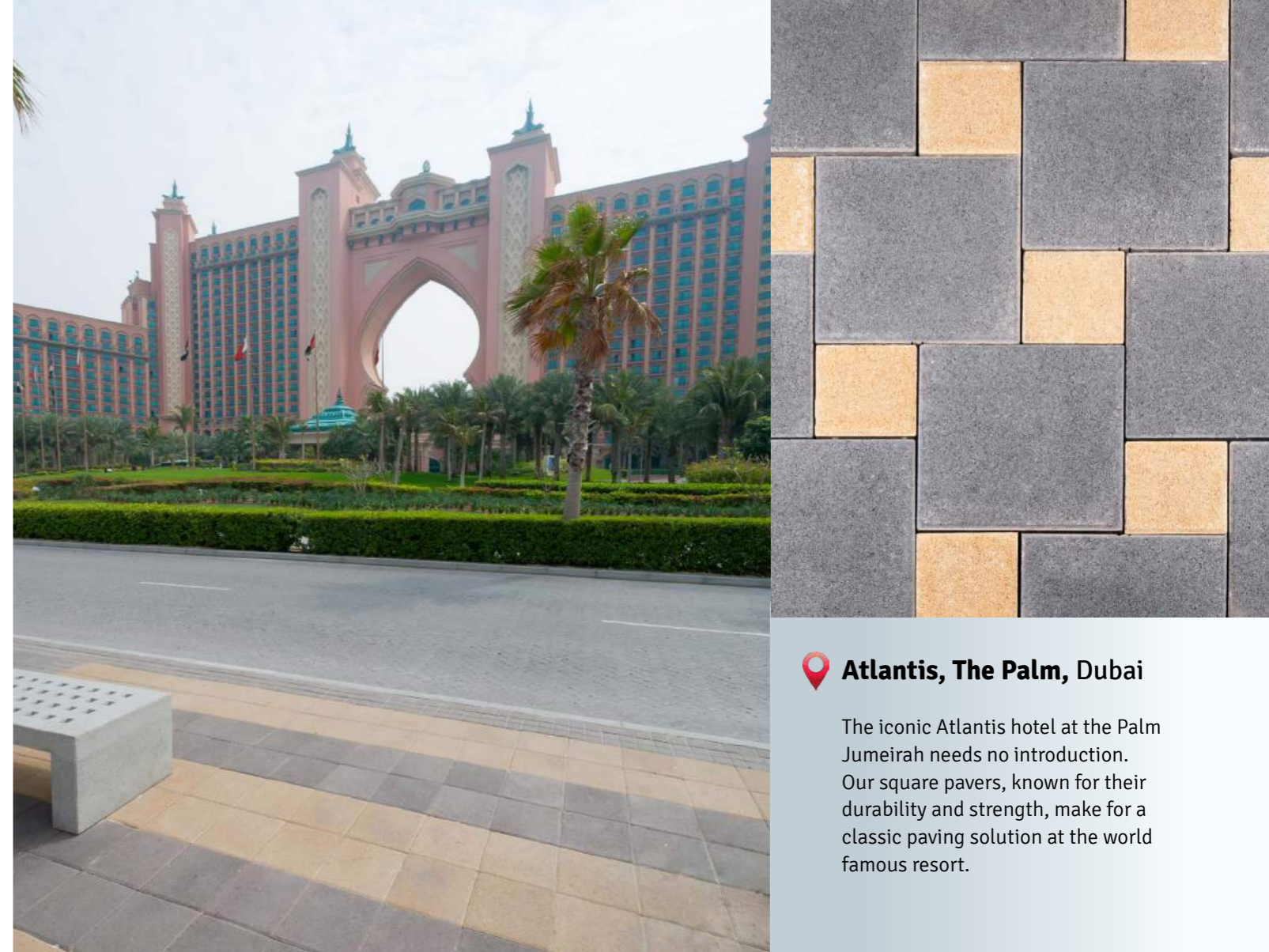

Atlantis, The Palm, Dubai

The iconic Atlantis hotel at the Palm Jumeirah needs no introduction. Our square pavers, known for their durability and strength, make for a classic paving solution at the world famous resort.



Zabeel Mosque, Dubai

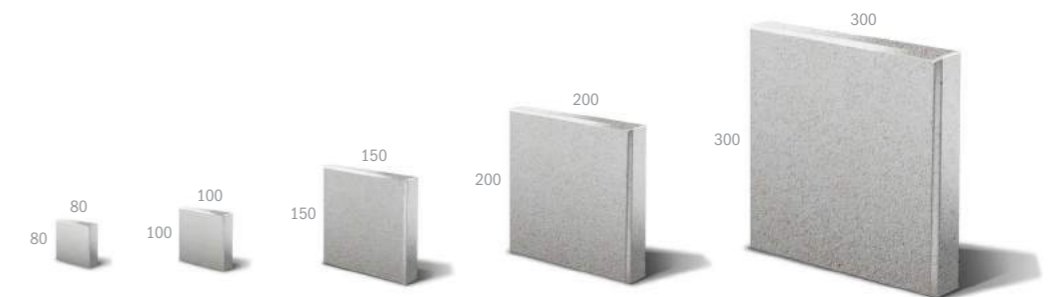

Item	Square										
	80		100		150		200		300		400
Length(mm)	80		100		150		200		300		400
Width(mm)	80		100		150		200		300		400
Thickness(mm)	60	80	60	80	80	60	80	60	80	60	
Weight of block (kg)	0.9	1.2	1.4	1.9	23	5.5	7.4	12.8	17.2	23	
Blocks /m ²	156.25	156.25	100	100	44.44	25	25	11.11	11.11	6.25	
Blocks/bundle	1260	1300	891	891	360	270	270	108	108	60	
Square meter/bundle	8.07	8.33	8.91	8.91	8.1	10.8	10.8	9.72	9.72	9.6	



1.12

PAVERS LaPlaza®

- Offers tremendous creative freedom in laying patterns
- Can be combined with square and rectangular pavers to create stunning results
- Suitable for outdoor decors that require a touch of glamour and sophistication

Allow your artistic side to take wing with the La Plaza series. Designed to work in perfect combination with the square and rectangular pavers, La Plaza offers you the freedom and flexibility to create custom patterns and user specific designs with tremendous ease.

La Plaza's characteristic designs evoke a touch of the Mediterranean, and will prove to be an elegant addition to any of your outdoor paving projects. The creative freedom it offers, coupled with its elegant and eclectic patterns, make the La Plaza range an artistic endeavour that lends an air of sophistication to any environment.

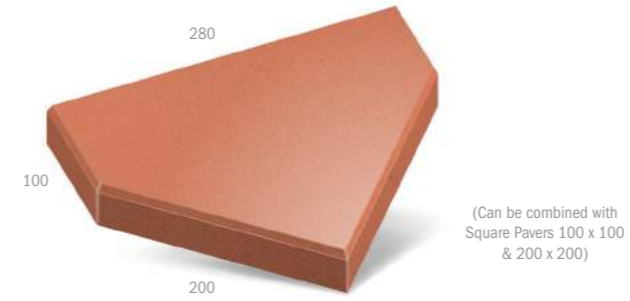

Item	La Plaza	
Length(mm)	280	
Width(mm)	100/200	
Thickness(mm)	60	80
Weight of block (kg)	7.2	9.06
Blocks /m ²	21	21
Blocks/bundle	126	126
Square meter/bundle	6.003	6.003

RECOMMENDED FINISHES



📍 Al Quoz Mosque, Dubai

The signature pattern of La Plaza serves as the perfect counterfoil for the main architectural focus in this complex at Al Quoz. The dark colours of the surrounding pavers serve to enhance the elegant beauty of the mosque.

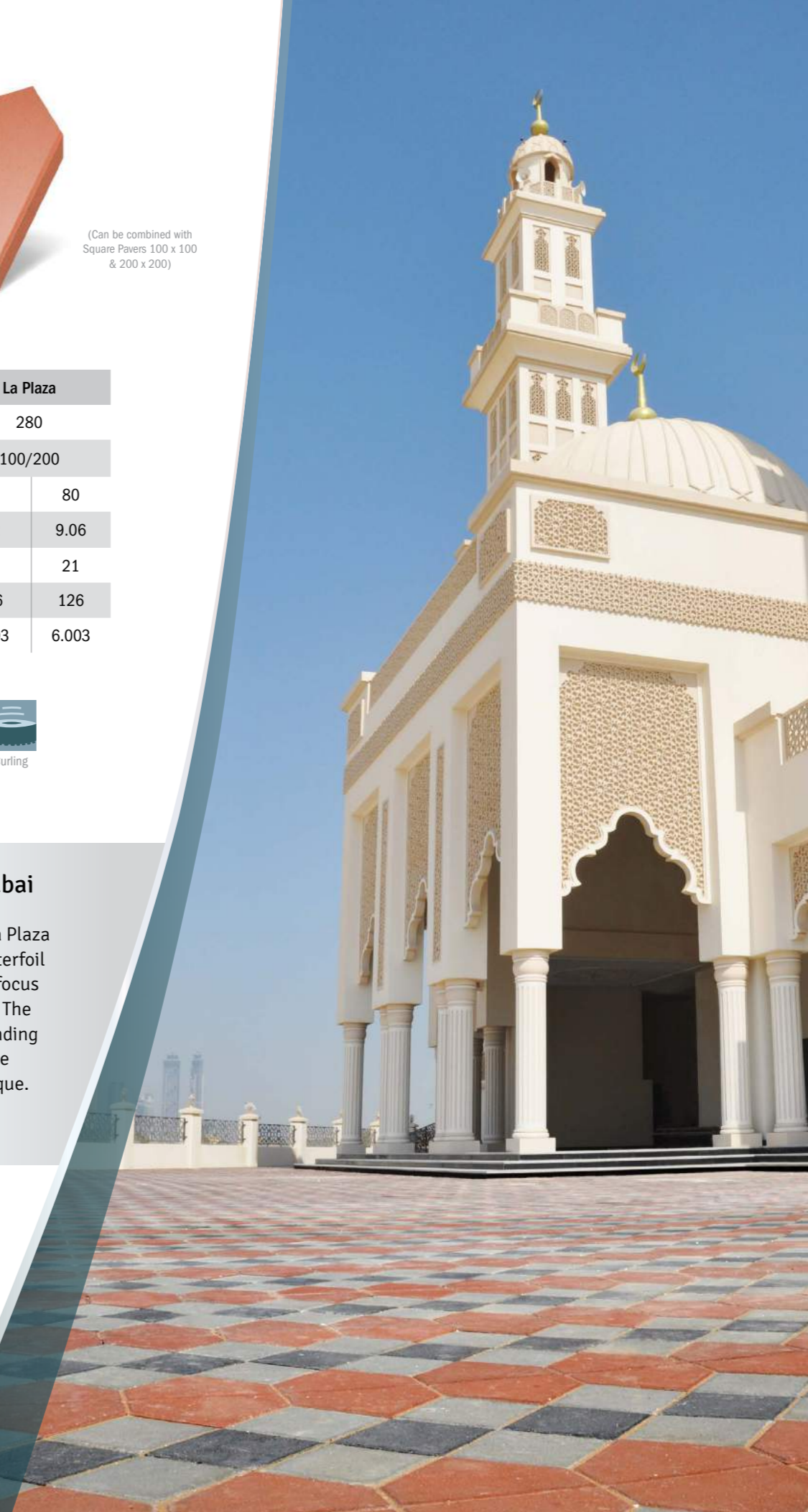
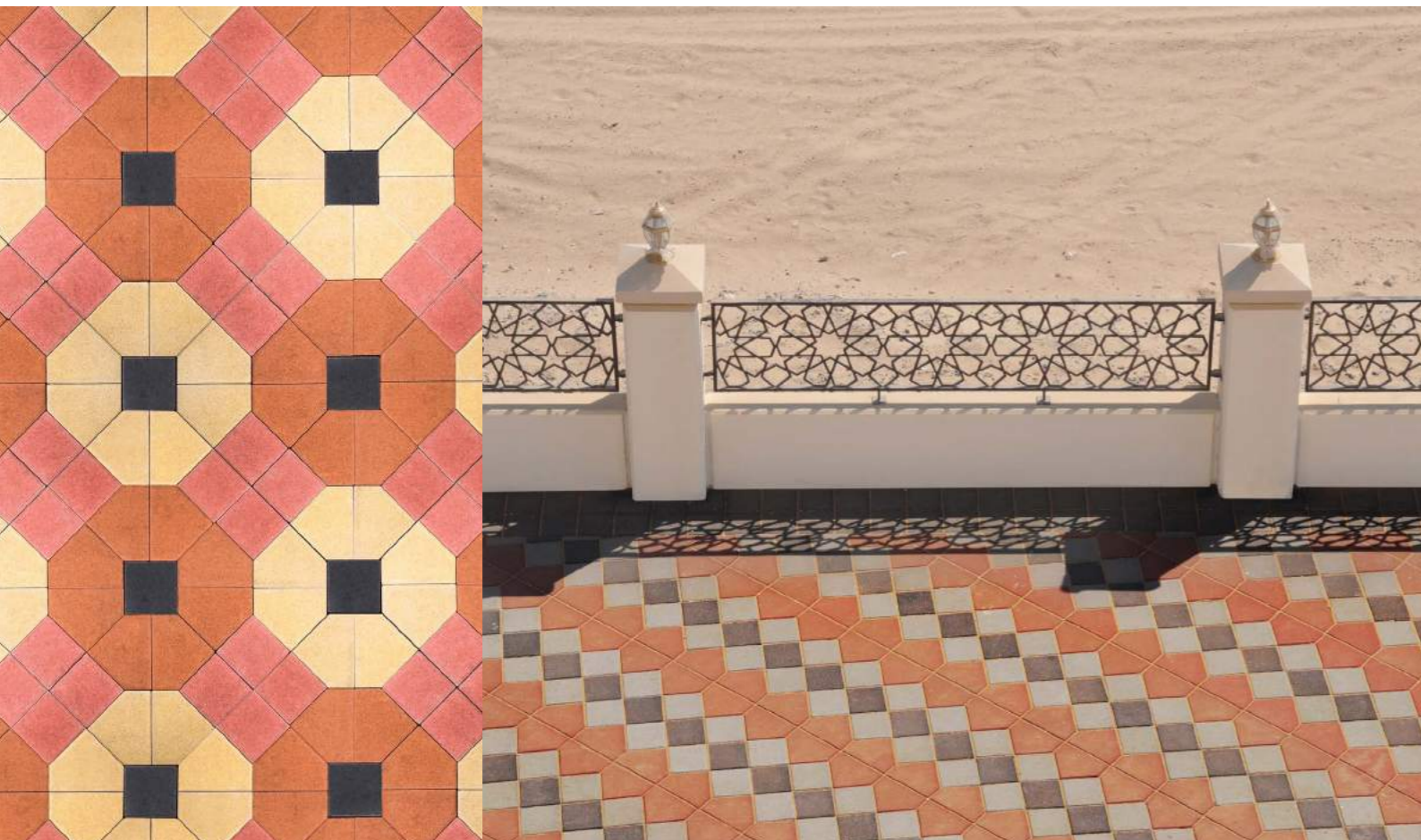

1.13

PAVERS Octapave

- Octapave creates a signature pattern employing the unique “octa” or 8-sided paver block
- Inherently strong locking strength makes it suitable for commercial and residential projects

For a truly eye-catching paving solution, explore the Octapave range which incorporates the unique “octa” or eight sided paver block. The Octapave series consists of three distinct shapes – the octagonal, quadro and cube. These three shapes can be used individually or in combination with each other to create a range of enticing patterns, made memorable by the unique eight-sided octagonal paver.

Octapavers have an inherently strong locking strength due to their shape, and are well suited for use in commercial and residential projects. Cost-effective with an exotic visual appeal, Octapavers are your first entry point into luxury. Make a signature statement with the Octapaver range for any of your custom paving needs.



Item	Quadro-I		Octagon		Cube	
Length(mm)	197		197		80	
Width(mm)	80/140		197		80	
Thickness(mm)	60	80	60	80	60	80
Weight of block (kg)	2.8	3.8	4.7	6.2	0.9	1.2
Blocks /m ²	51	51	30	30	156.25	156.25
Blocks/bundle	378	378	216	216	1260	1300
Square meter/bundle	7.41	7.41	7.2	7.2	8.07	8.33

RECOMMENDED FINISHES

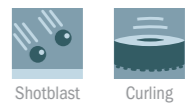

1.14

PAVERS Uni

- Renowned for superior locking strength of the Unipaver shape
- Capable of taking on enormous vehicular load

Economical and ubiquitous, the unipaver is one of our most popular paving solutions. The Uni is most renowned for its superior locking strength. Its serrated edges ensure that each block fits snugly against the next, creating an interlocked pattern capable of taking on enormous loads. The inherent shape of the paver, with its two axis upon which concentrated loads can be placed, results in a uniform distribution of weight and an optimal release of tension. This explains the Uni's outstanding durability, and why it is commonly used for covering large areas that witness heavy vehicular and pedestrian traffic.

Another reason for its popularity is that it remains unaffected by changes in season, be it scorching summers or biting winters, and requires no extra maintenance. The Unipaver can be laid in various patterns such as the stretcherboard, basket weave or herringbone. The Unistarter shape is used in tandem with Unipaver to create straight edges for the paving areas.

Item	Unipaver		
Length(mm)	225		
Width(mm)	112.5		
Thickness(mm)	60	80	100
Weight of block (kg)	3.57	4.72	6.00
Blocks /m ²	40	40	40
Blocks/bundle	400	400	280
Square meter/bundle	10.00	10.00	7.00

Item	Unistarter	
Length(mm)	315	
Width(mm)	225	
Thickness(mm)	60	80
Weight of block (kg)	4.37	5.75
Blocks /m ²	32	32
Blocks/bundle	216	216
Square meter/bundle	6.75	6.75

RECOMMENDED FINISHES



Normal



 **Zabeel Mosque, Dubai**

Kingdom of Sheba, Dubai

A mixed-use luxury resort, Kingdom of Sheba holds pride of place at the iconic Palm Jumeirah. Transgulf's Unipaver series offers the strength and durability needed for pedestrian & vehicular traffic.



1.15

PAVERS Behaton

- Ideal for large areas that witness heavy loads such as warehouses and parking lots
- Intrinsic shape and interlocking patterns provides maximum strength to withstand extreme loads

A tough, hardy paving solution for extreme conditions, the Behaton paver is noted for its strength and stability. The structural shape of the Behaton paver guarantees tremendous interlocking strength, making it an ideal paving solution for large scale industrial areas, warehouses and parking lots and other areas which bear heavy-duty vehicular traffic.

An added advantage lies in the fact that the Behaton requires little maintenance and is a hassle free paving solution come rain or shine.



 Technopark, Dubai

 **Technopark, Dubai**

Behaton is commonly used for parking lots, warehouses and similar areas that witness heavy motor traffic.

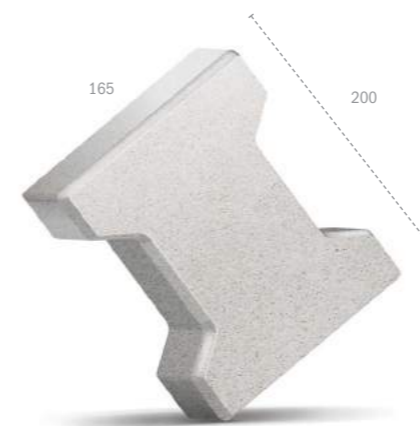

Item	Behaton
Length(mm)	200
Width(mm)	165
Thickness(mm)	80
Weight of block (kg)	5.2
Blocks /m ²	35.7
Blocks/bundle	360
Square meter/bundle	10.08

RECOMMENDED FINISHES



1.16

PAVERS Honeycomb®

- Exceptional strength due to the high grade concrete used in manufacturing
- Ideal for heavy-duty applications such as industrial roadways, airports and car parks

The super strong Honeycomb paving system brings together the superior interlocking strength of the industrial paver and a stunning contemporary design in one unparalleled combination. Manufactured from high strength concrete, they are exceptionally tough and can withstand extreme loads and high stress.

Honeycomb's strength and durability make it a perfect choice for heavy-duty applications such as industrial roadways, airports, container terminals, rail yards and car parks. Owing to the high strength concrete from which they are manufactured, Honeycomb pavings design is inspired by nature thus survive well beyond normal life expectations, proving to be cost effective solution in the long term.

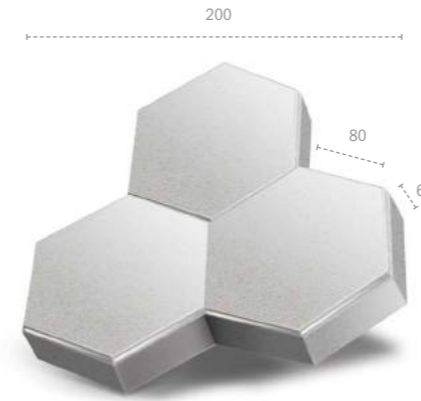

Item	Tri-Hex
Length(mm)	200
Side(mm)	60
Thickness(mm)	80
Weight of block (kg)	4.8
Blocks /m ²	39.375
Blocks/bundle	315
Square meter/bundle	8



 Private Apartments, Dubai

SAMA Dubai Accomadation, Dubai

This apartment complex, Jebel Ali uses Transgulf's Honeycomb series as the paver of choice for their parking lots. The simple grey Honeycomb provides an elegant counterpart for the multicoloured apartment block.



1.17

PAVERS Monaco

- Simple, intricate patterns work beautifully for outdoor spaces
- A range of textures and effects are available for creating different patterns

Another paver inspired by geometric designs, the six-sided Monaco incorporates the latest in our product advancements and technology. In combination with the square and rectangular pavers, Monaco also offers a versatile range of intricate laying patterns that add a sense of beauty and warmth to your environments. With a strong Mediterranean aesthetic, this series is a striking addition to any outdoor living space.

Monaco based designs work best across large installations as their detailed patterns add a sense of character to large expanses. With an intricate pattern Choose from our wide variety of colours and finishes to create interesting patterns and designs.

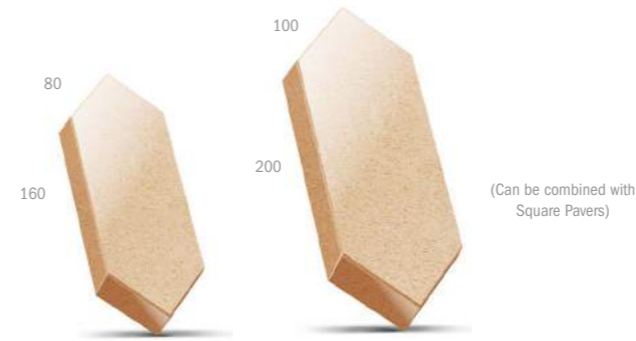

Item	Monaco Classic	Monaco New
Longer Side (mm)	160	200
Other Side (mm)	80	100
Thickness (mm)	80	80
Weight of block (kg)	4.7	7.5
Blocks /m ²	40.85	26
Blocks/bundle	297	207
Square meter/bundle	7.27	7.96

RECOMMENDED FINISHES



ADNOC outlets, Abu Dhabi

This intricate design uses the Monaco shape, adding interest and character to the featured ADNOC outlet in Abu Dhabi. The otherwise plain landscape which covers a large area is transformed into an eye-catching pattern using the Monaco range.



Adnoc outlet, Abu Dhabi

1.18

PAVERS Rectangular®

- One of the oldest and most commonly used pavers
- Ideal for pedestrian walkways, pathways and patios
- Popular for being extremely cost effective yet versatile

The Rectangular paver is one of the simplest and most widely used paver shapes worldwide. Prevalent from ancient Roman times, the Rectangular shape is a timeless classic popular for its ease of use and versatility. They are easy to pack and move, and can be laid in a range of interesting patterns that work well in most scenarios. With a high degree of resistance to loads, Rectangular pavers are commonly used for areas with high pedestrian traffic such as sidewalks of major roads and walkways in supermarkets, parks and patios.

Look beyond its initial simplicity, and the Rectangular paver can surprise with its limitless design possibilities. Two starter tiles – the triangular starter and the rectangular starter - are available for use with the rectangular paver.



Grand Mosque, Abu Dhabi

Transgulf's rectangular pavers can be seen lining the exteriors of the magnificent Grand Mosque at Abu Dhabi. The chosen neutral colour of the rectangular pavers complements the pure white of the mosque in the background.

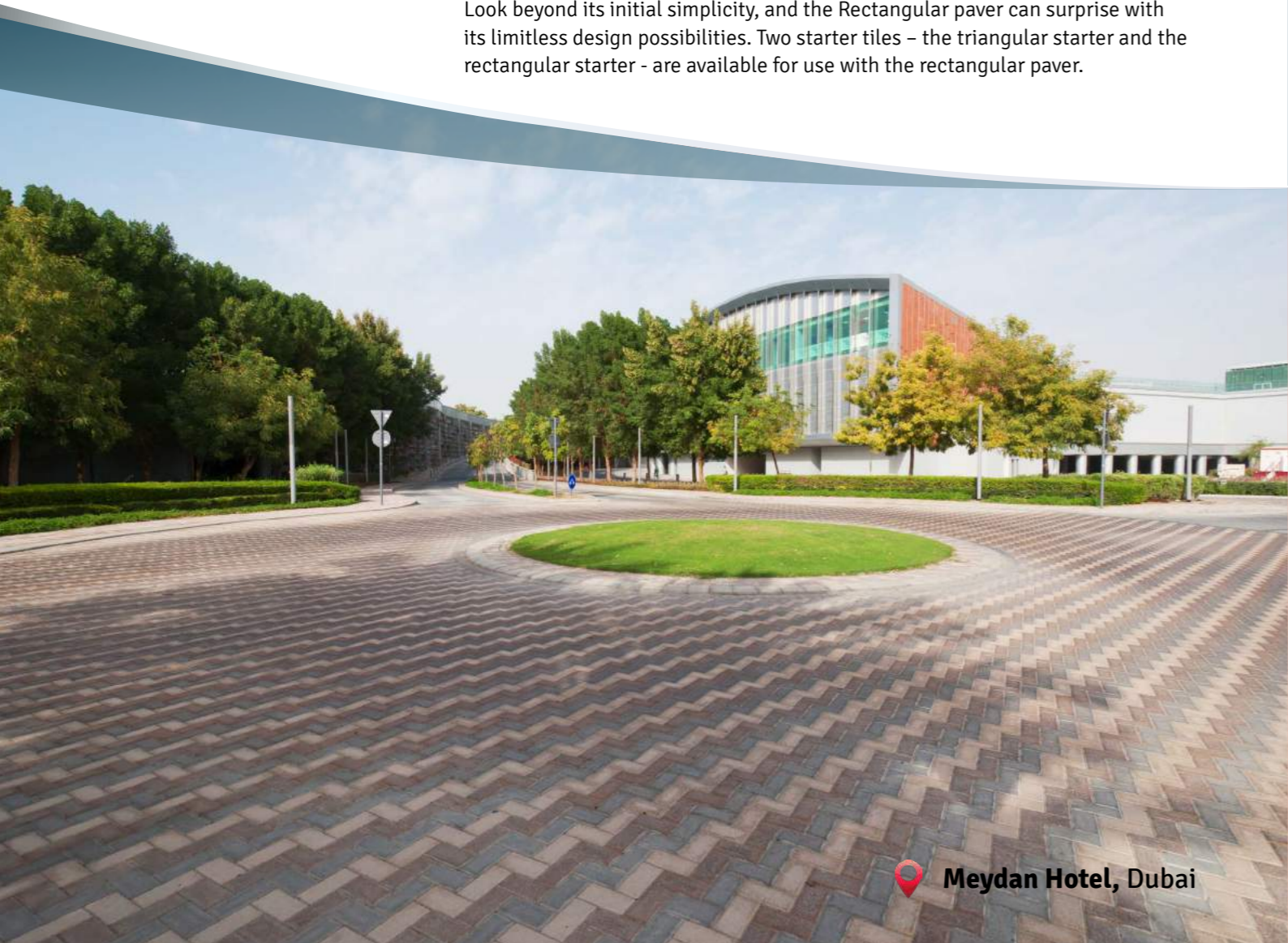

Meydan Hotel, Dubai



Item	Rectangular		
Length(mm)	200		
Width(mm)	100		
Thickness(mm)	60	80	100
Weight of block (kg)	2.85	3.85	4.85
Blocks /m ²	50	50	50
Blocks/bundle	486	486	384
Square meter/bundle	9.72	9.72	7.68



Item	Traingular Starter	
Length(mm)	140	
Width(mm)	100	
Thickness(mm)	60	80
Weight of block (kg)	2.7	3.7
Blocks /m ²	52.5	52.5
Blocks/bundle	378	405
Square meter/bundle	7.2	7.74



Item	BH Starter
Length(mm)	268.4
Width(mm)	192.9
Thickness(mm)	60
Weight of block (kg)	3.6
Blocks /m ²	50
Blocks/bundle	432
Square meter/bundle	8.64

RECOMMENDED FINISHES



1.19

PAVERS Grasscrete

- A permeable paving system for use in lawns, gardens and natural surroundings
- With a high load bearing capacity, Grasscrete can be used to create a range of interesting features

A beautiful compliment to the lush greens of nature, the Grasscrete paver can be used for creating walkways and driveways in gardens, lawns and parks. A permeable paving system, Grasscrete pavers protect the turf they encircle while subtly enhancing the beauty of the surroundings.

With one of the highest load bearing capacity of all pavers, Grasscrete can be used to create a variety of interesting features in gardens, public parks and other natural surroundings.

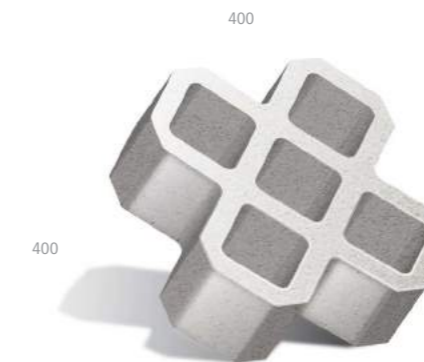
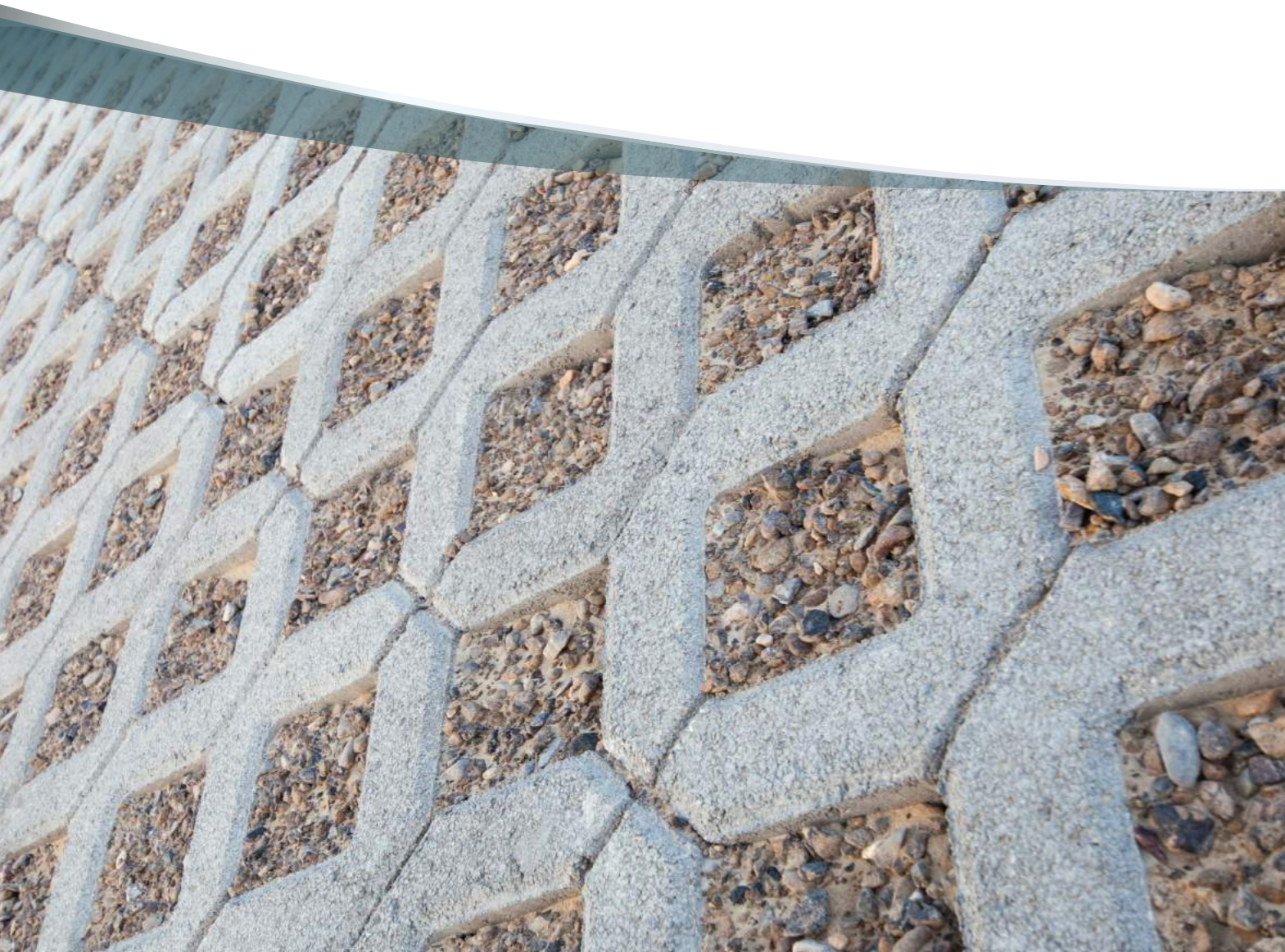

Item	Grasscrete
Length(mm)	400
Width(mm)	400
Thickness(mm)	150
Weight of block (kg)	36
Blocks /m ²	6.25
Blocks/bundle	36
Square meter/bundle	5.76

RECOMMENDED FINISHES
Normal

1.20

PAVERS La Rambla®

• La Rambla is available in multiple colors, with different shapes and sizes, enhanced by excellent finishing, making it suitable for a variety of outdoor décors and environments.

A traditional paving style inspired by world renowned Spanish architecture, La Rambla is designed to represent a wave-like pattern, adding its unique feel and touch to the overall ambiance. The paver is featured at numerous avenues, boulevards and seating areas



Item	La Rambla
Length(mm)	600
Width(mm)	400
Thickness(mm)	60
Weight of block (kg)	34.7
Blocks /m ²	4.167
Square meter/bundle	9.6

RECOMMENDED FINISHES



Multi-Color Honed Diamond Cut

Miracle Garden, Dubai

La Rambla's three dimensional, wave-like design heightens the memorable experience in the new extension of Miracle Garden, Dubai.



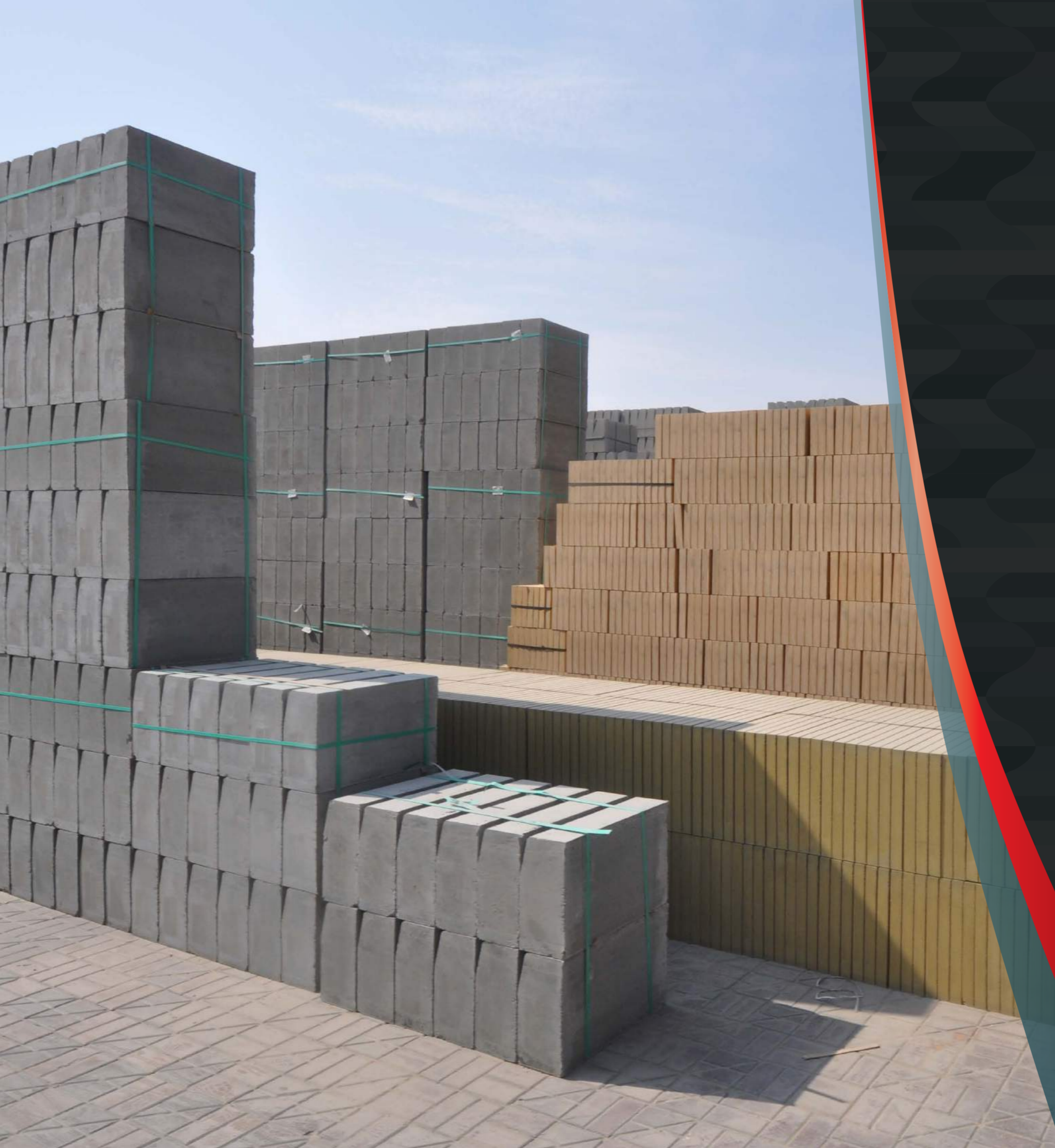

2 KERBS

Our ranges of hydraulically pressed Kerbstones are designed to complement block paving and at the same time serves as an ideal, attractive and versatile edge restraint. Extensive engineering and a good selection of components make this an exceptional bonding unit for paving blocks.

Kerbing improves delineation of road edges and contributes to the appearance and safety of the road. Some of the main purposes of the kerbstone are:

- Improvement of aesthetic values of the road alignment.
- To protect pedestrians.
- To assist drainage.
- To improve channelization and delineation of traffic flows.

All Transgulf's kerbstones meet BS 7263 specifications.



2.1

KERBS Heel Kerb

- A simple, economical edge kerbs that gels with all paving styles
- Heel kerbs come with a dentate that help adjacent kerbs to “interlock”

The heel kerb is one of the most economical of all kerbstone varieties. A small unit kerb, it is designed for maximum versatility with the ability to combine harmoniously with any of our varied paving styles. Our heel kerbs are made using two-part vibrating technology, fortifying the kerb for maximum strength.

Heel kerbs come with a unique dentate that helps one kerb “interlock” with the next. This is a unique feature within kerbs and helps this range have an excellent connecting strength. Available in a variety of colours and finishes to use with varied paving styles, the heel kerb is a simple, universal solution to any of your kerb needs.

Item	Heel Kerb	
Length(mm)	600	600
Width(mm)	75	100
Thickness(mm)	150	200
Weight of block (kg)	16	28.5
Blocks /lm	1.66	1.66
Blocks/bundle	88	72
LM/bundle	52.8	43.2



RECOMMENDED FINISHES



Grand Mosque, Abu Dhabi

Transgulf’s heel kerb serves multiple purposes in the Grand Mosque, acting as a design element in the park as well as a walkway in the middle of the grass.



 Grand Mosque, Abu Dhabi

2.2

KERBS Sienna®Kerb

- Suitable for a variety of applications from lining patios to driveways
- A careful consideration of the colours and textures available in Tegula results in stunning effects
- A Sienna kerb which can be laid in 5 different positions to get a variety of laying options

The versatility of the Sienna kerbstones is one of the reasons for its popularity. With Sienna, it is particularly worth investing time and giving some thought into the selection of colours from our wide range of options. Dark coloured kerbstones go well with lighter pavings. Such a contrast enhances the appearance of the landscaped area and provides more interest to the human eye.

Also known as Tegula kerb it can be used in a variety of applications to add a bold statement to your landscape design. Tegula is popularly used to line gardens, pavements and driveway edges, and tree islands.

Item	Tegula Kerb
Length(mm)	100
Width(mm)	125
Thickness(mm)	200
Weight of block (kg)	5.6
Blocks /lm	10
Blocks/bundle	324
LM/bundle	32.4



RECOMMENDED FINISHES



📍 Private Villa, Dubai

The Sienna Kerb is popular among private residential villas, adding to their beauty and sophistication, while being being purposeful at the same time.



📍 Private Villa, Dubai

2.3

KERBS Half Battered

- One of the most widely used kerbing solutions worldwide
- Known for its strength and durability
- The battered face offers some special advantages within kerbstones

One of the most widely seen varieties worldwide, the half battered kerb is a cost effective and extremely popular kerbing solution. Its main function is to warn motorists of being too close to the edge of the carriageway. The inherent shape of the half battered kerb also has the additional advantage of allowing road rollers to operate right up to the edge of the pavement without scratching or damaging the kerb surface.

An extremely popular kerbing solution for major roadways and pathways, half-battered kerbstones are available in a variety of colours and finishes to suit various paving styles.



Half Battered, Kerb Sizes:

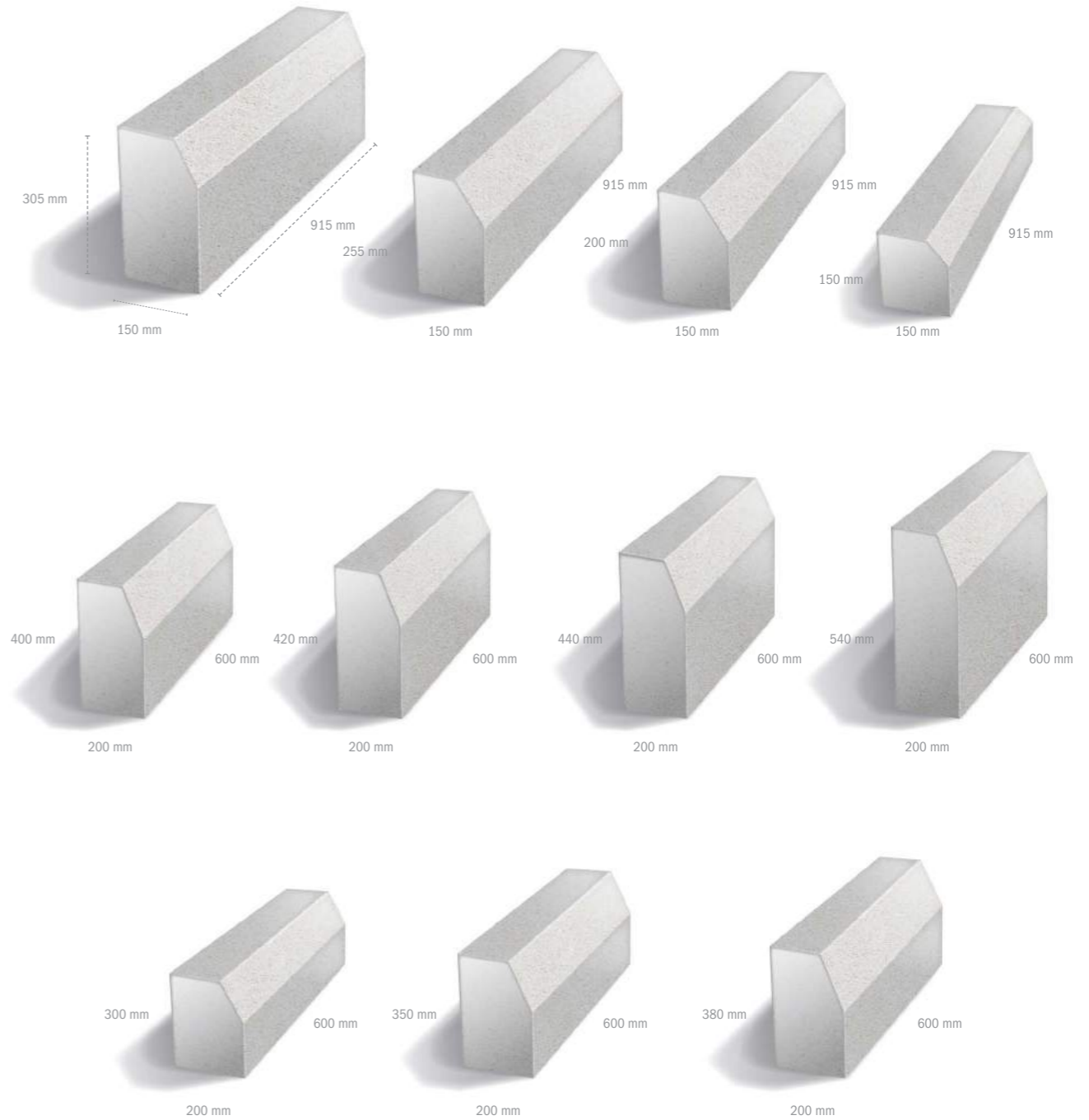

RECOMMENDED FINISHES



2.4

KERBS Flush Kerb

- Flush kerbs' distinctive feature are its sharp, right angles
- Can easily be laid flush with the street level for driveways

The flush kerb, so named for its right-angled edges and straight lines, are most commonly seen in residential neighborhoods with light vehicular traffic. In such areas that witness heavy footfalls, the flush kerb allows a straight step down for pedestrians, thus making them less likely to trip over kerbs. Another reason for their popularity stems from the fact that flush kerbs require minimum modification when being laid at driveway entrances of homes and villas. The straight edges of the flush kerb allow them to be easily laid flush with the carriageway to provide access for cars.

Flush kerbs are available in a variety of colours and finishes to suit any of your kerbing projects.



Flush, Kerb Sizes:

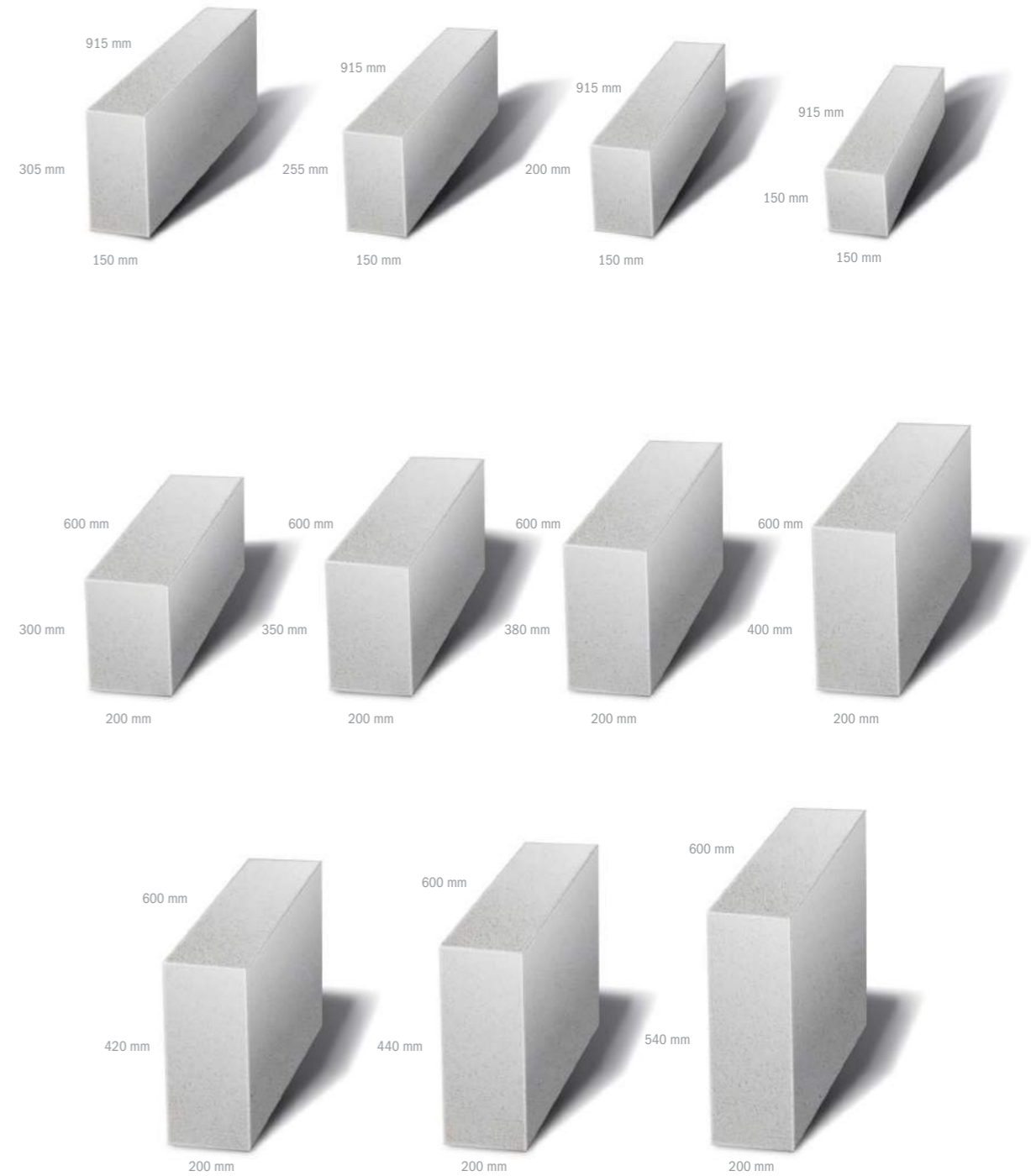

RECOMMENDED FINISHES



2.5

KERBS Bullnose Kerb

- Bullnose kerbs have a soft edge restraint for a smooth, gentle look
- Suitable for a variety of applications, including as borders for pathways, flowerbeds

The bullnose kerb provides a soft edge restraint to the kerbstone, while continuing to maintain a 90-degree angle to the ground. Due to this smooth, curved edge, the bullnose is well suited for a variety of applications, including being used to border pathways, steps and flowerbeds with the aim of providing definition.

When a crossing is required, normally for access to a private driveway or pedestrian crossing, a bullnose curb sequence is used. Choose from a variety of colours and finishes in the bullnose series to suit your environment.



Bullnose, Kerb Sizes:

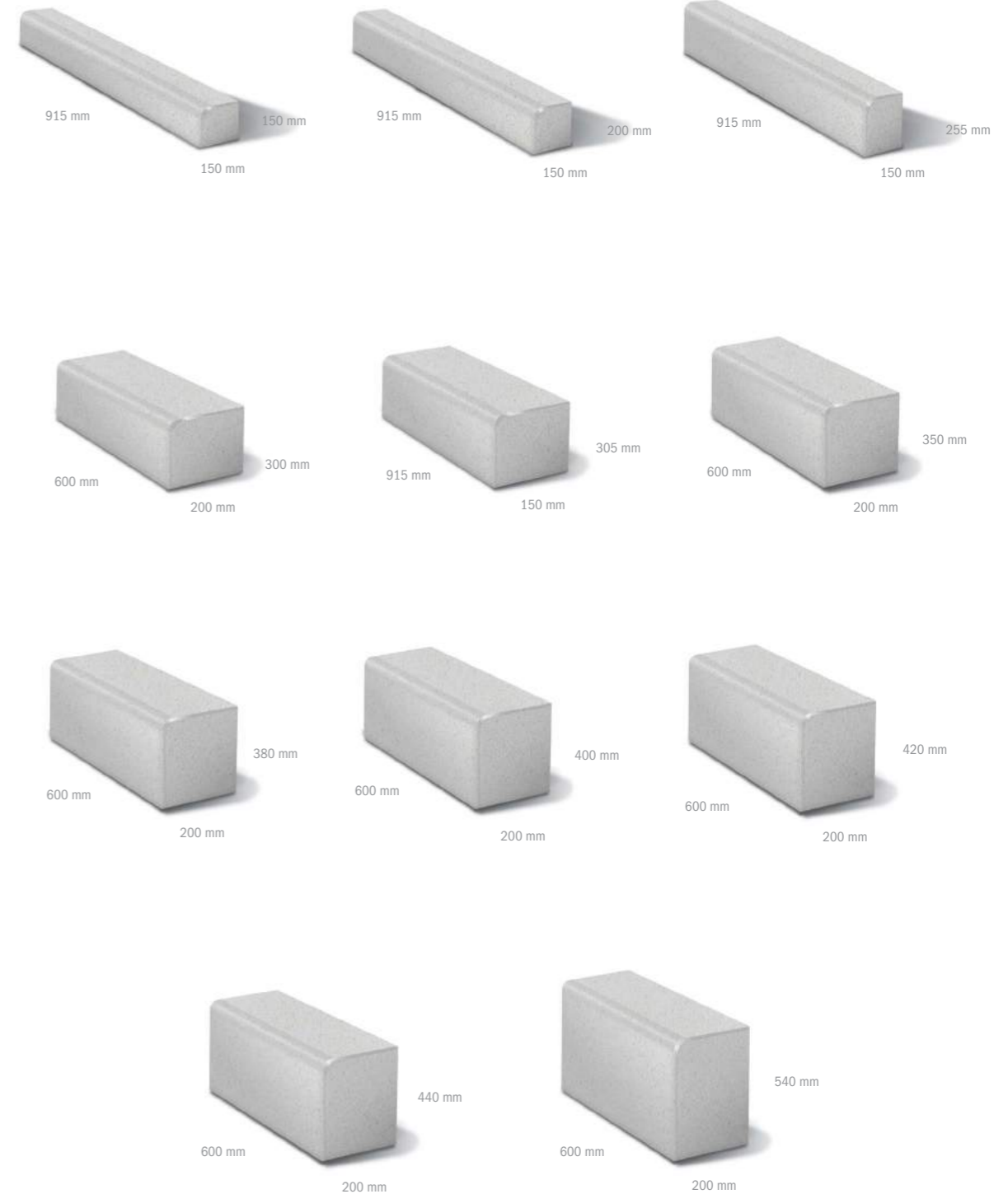

RECOMMENDED FINISHES



2.6

KERBS Gutter Kerb

- Used to channel surface water or run from the edge of the carriage way
- Also provides a spacer between the edge of the road and the start of the kerb

Gutter kerb is a concrete structure typically located at the edge of a road designed to provide road drainage, and as a barrier to prevent vehicles from leaving the road carriage way. The kerb is shaped in a way that allows easy flow of water to drainage, while in case the road is dry, it provides a sleek feel to the road as it merges with the pedestrian walkway.



Gutter, Kerb Sizes:

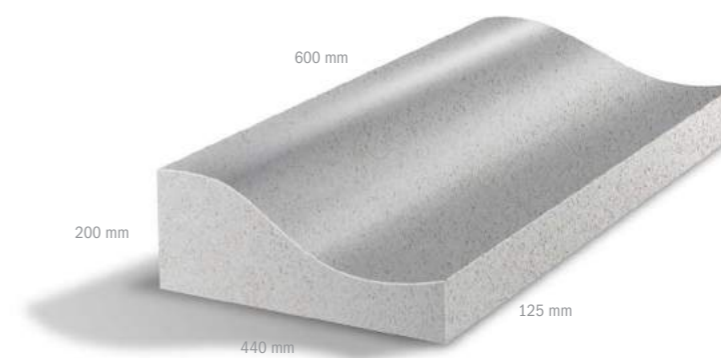
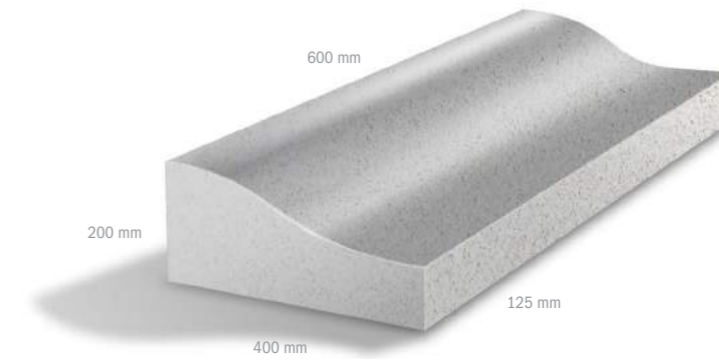
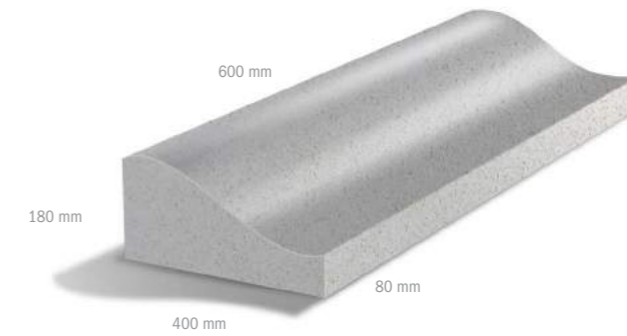

RECOMMENDED FINISHES



2.7

KERBS Barrier Kerb

- The inherent shape of the barrier kerb, with its steep face, acts as a deterrent to vehicular traffic
- Barrier kerbs act as a deterrent to motorists from coming too close to pavement edges and other sensitive areas

Barrier kerbs, as the very name suggests, are intended to prevent vehicle encroachments from one side of the carriage way to the other. Barrier kerbs are used to distinguish sections and separate opposing traffic flow, thereby restricting drivers to their side of the road.

The intrinsic shape of the barrier kerb with its steep concave face, acts as a deterrent to motorists, thus reducing the risk to pedestrians walking on pavements. Another common application of the barrier kerb is to protect vulnerable footpaths such as pedestrian islands and dangerous curves. They are commonly used to line and protect sensitive roadside equipment such as fuel pumps at filling stations as well.



Barrier Kerb, Texture

Barrier, Kerb Sizes:

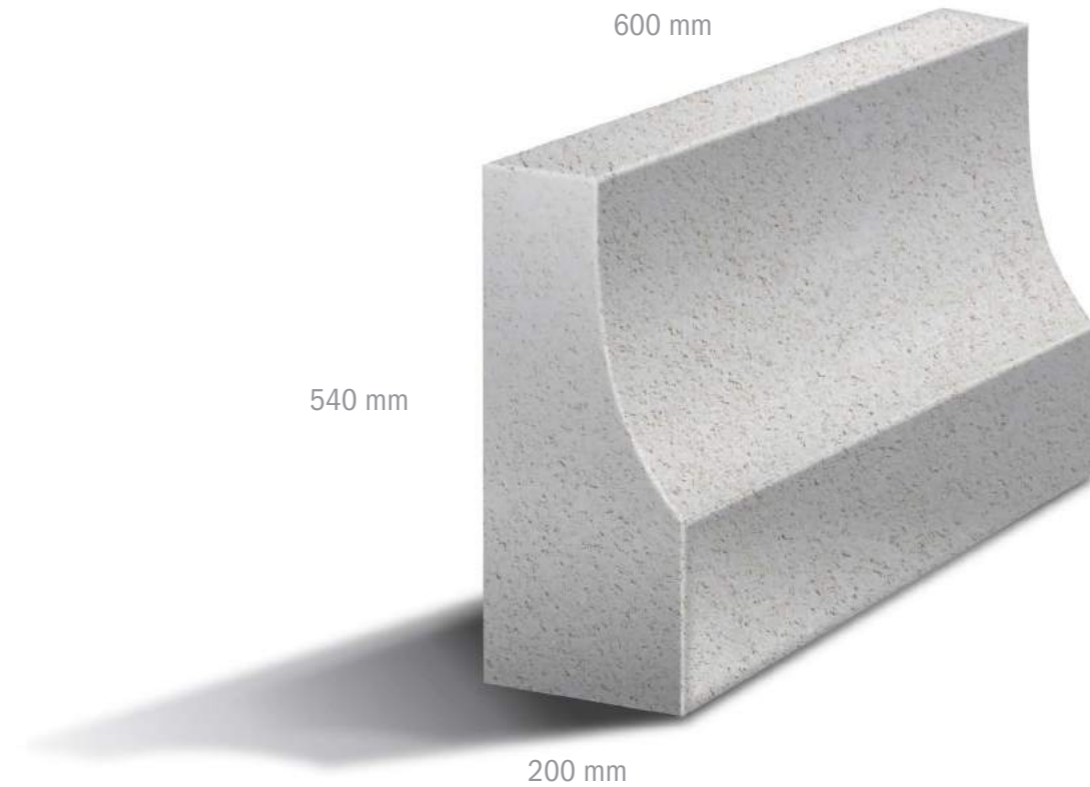

RECOMMENDED FINISHES



2.8

KERBS Rollover Kerb

Transgulf's rollover kerb is an ideal kerb to be used as a separator between the pavement and the grass or road area. Its curve shape allows it to be simple yet add a little design to the environment, and also to be used at multiple purposes. The simple purpose based application allows the architect or exterior designer to use it according to the location setting.



Rollover, Kerb Sizes:

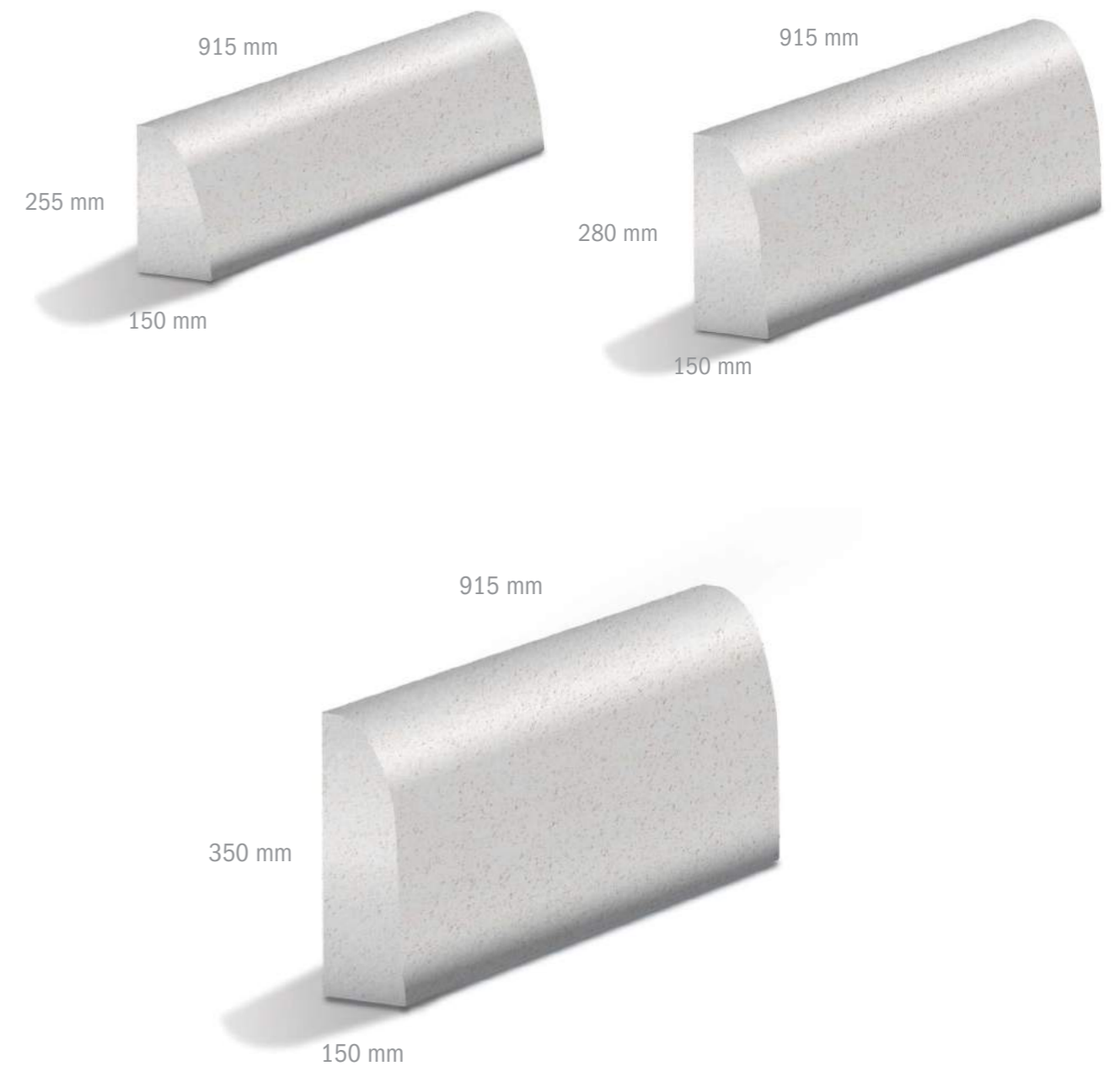

RECOMMENDED FINISHES



2.9

KERBS Channel Kerb

- Used to channel surface water or run from the edge of the carriageway
- Also provides a spacer between the edge of the road and the start of the kerb

Channel Kerbs provide a gutter for drainage of surface water and also a spacer between the edge asphalt and the face of the kerb. They are often laid as a restraining edge to those carriageways where no check is required, usually access roads where surface water is shed to each side of the carriageway or pavements where some form of drain is placed just outside the edge of the hard pavement.



Channel, Kerb Sizes:

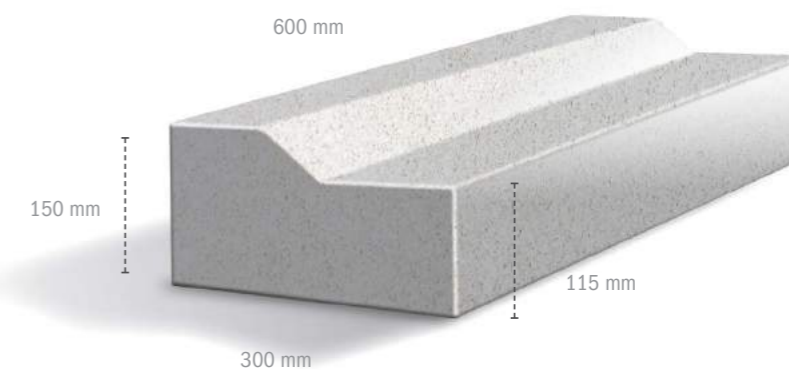
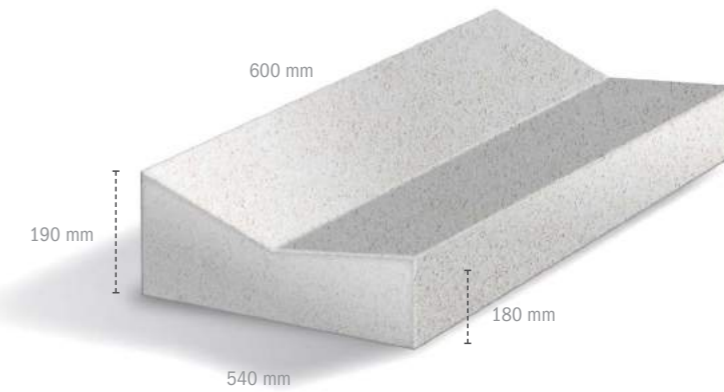

RECOMMENDED FINISHES



2.10

KERBS Wheel Stopper

- Used specially in parking area as a type of stopping units.

Our wheel stopper kerbs are high strength, thick material blocks, and are usually placed to limit the vehicles from going ahead more than the prescribed area. The inner strength of the kerb allows it to be solid barrier, while not to be so solid that it damages the object bumping into it. This is of most importance when used in parking lots, to allow for maximum utilisation of the space, as well as protecting the vehicles from crashing into walls or entering pavements or parks.



Wheel Stopper, Kerb Sizes:

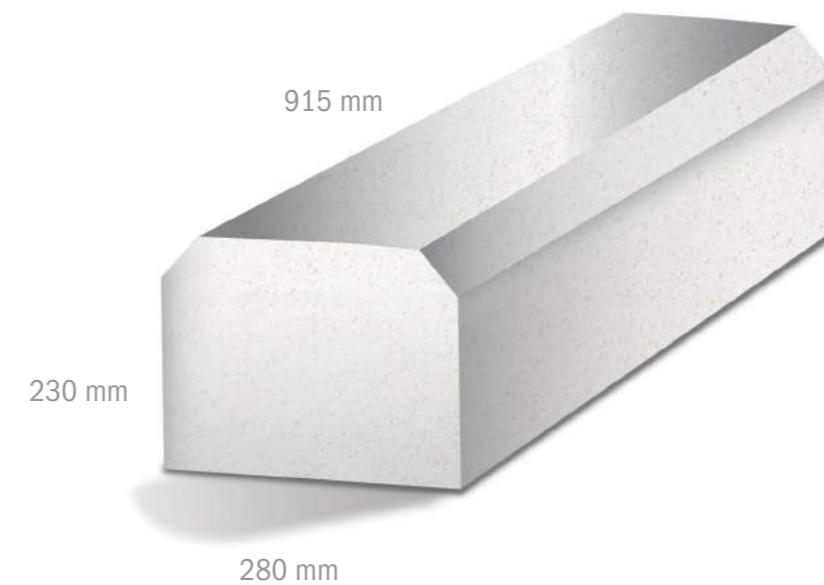
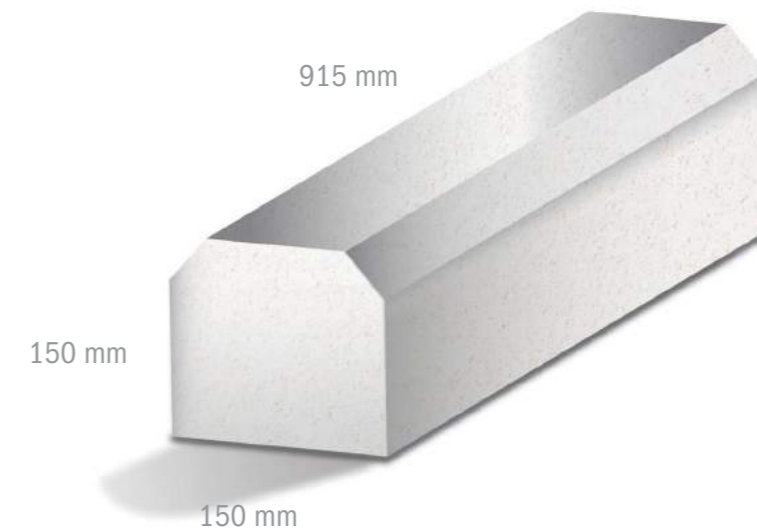

RECOMMENDED FINISHES





3 TILES

Transgulf's tiles are highly versatile. They are mainly used for public walkways, yards and simply everywhere else you desire.

Our tiles are made of concrete with natural aggregate and are available in different sizes to meet your requirement. Our choice of distinctive color and finishes will simply allow you to select the right tile for your designated environment.

Transgulf's tiles are manufactured using hydraulically pressed wet mix.

Tiles are manufactured as per British Standards.



www.tgcp.ae

3

TILES

When it comes to creating an experience, every single element of the site is important in making the right impression. While many may not notice a good tile design, structure and its particular role in the overall ambiance, but if anything is wrong, the same tile is bound to be noticed. Transgulf's Hydraulic Press Tiles are built with precision to ensure durability, making it ideal for places having low as well as high foot fall, adding a different level of perfection to the overall experience of your site.

Available Finishes

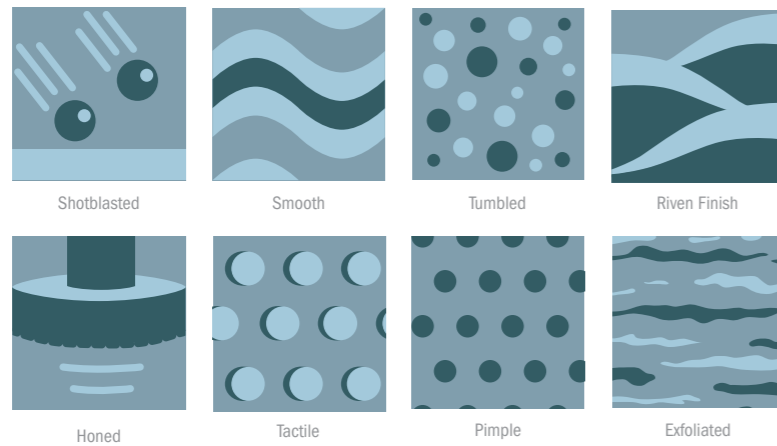

Salam Street, Abu Dhabi

Transgulf's tiles are placed on one of Abu Dhabi's main streets, multiple colors of tiles are placed together to create a simple yet attractive walkway for pedestrians as well as adding to the beauty of the UAE capital emirate.

Salam Street, Abu Dhabi

Each of our tiles is manufactured with standard top-quality materials, employing state of the art hydraulic press technology. Ideally tiles of multiple colors are placed together to add to the design element of the site, cutting down maintenance costs.

Our tiles fit perfectly with each other, creating a flawless, comfortably smooth walkway. Transgulf offers a wide range of sizes, colors and textures, making our tiles suitable for places of completely different natures, from sports stadiums to beaches, from public parks to monumental mosques.

Sizes (mm)	Thickness (mm)
300 X 300	40/60/80
400 X 400	40/60/80
400 X 200	40/60/80
450 X 450	40/60/80
500 X 500	50/60/80
500 X 250	50/60/80
600 X 600	50/60/80
600 X 300	50/60/80
600 X 400	50/60/80
800 X 400	60/80
1000 X 300	60/80
1000 X 250	60/80
1000 X 500	60/80

3

TILES

The process of hydraulic press allows for not only efficient, cost effective production of tiles, but also for standardization and perfection. Transgulf uses the highest level of scientific equipment and process for production of tiles, ensuring sustainability, durability and perfection in each and every tile.

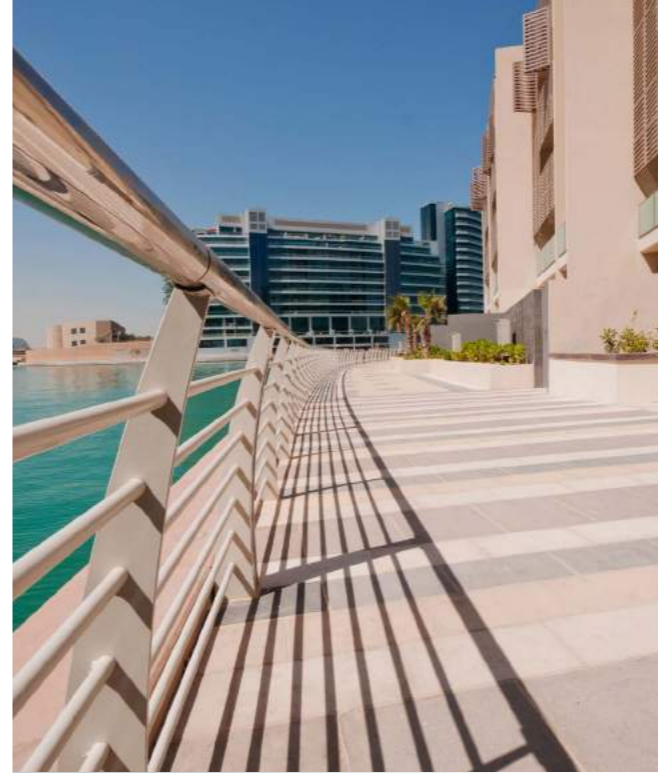

Raha Beach, Abu Dhabi

Transgulf's tiles are an essential part of the beautiful posh residency at Al Raha beach, its smooth as well as textured pattern adds simple class to the location's sophistication.

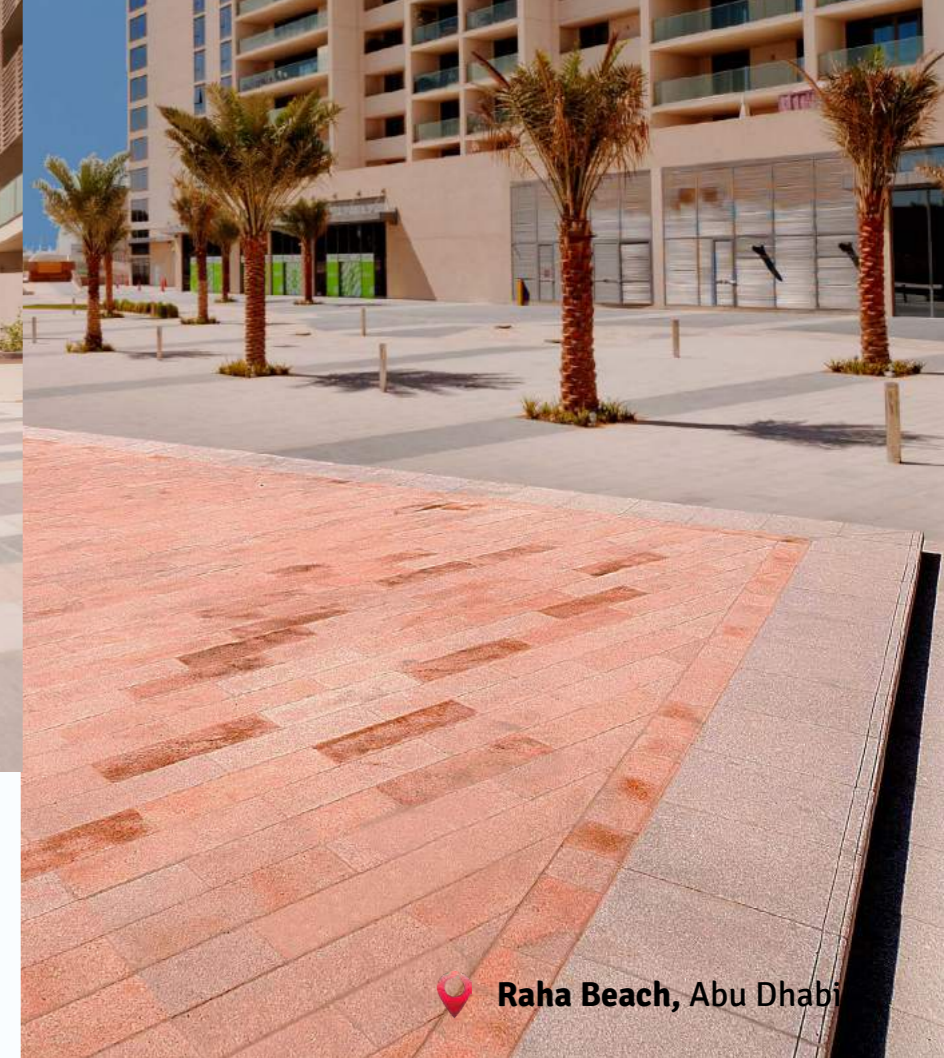

Raha Beach, Abu Dhabi



Miracle Garden, Dubai



Raha Beach, Abu Dhabi



Grand Mosque, Abu Dhabi

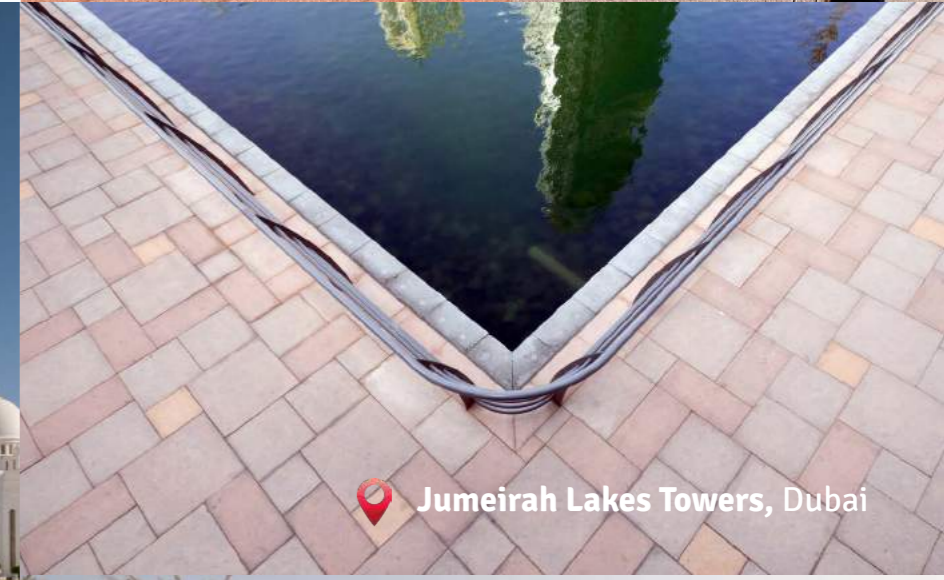

Jumeirah Lakes Towers, Dubai



Meydan Hotel, Dubai



Municipality, Abu Dhabi



American University, Sharjah



4

MASONRY BLOCKS

Our multi-utilitarian masonry blocks produce hi quality walls that are secure and stable, with perfect thermal and sound insulation. Manufactured from naturally occurring aggregates, our masonry blocks are extensively used as substitutes for conventional wood-frames for high-grade exterior walls. They are fortified from the inside out with a high level of resistance to aging, fire, environmental damage and weathering, a range of masonry blocks is available from standard structural units to blocks made for custom requirements.



www.tgcp.ae

4

MASONRY BLOCK

4.1 Hollow Block

Transgulf's Hollow blocks are manufactured in compliance with international standards (ASTM ,BS,BS EN,DM,ADM etc) as specified by the project specification and the requirements. Blocks are the main constituent for the construction technology, Transgulf's are manufactured as per the standard dimensions, using uniform material content, ensuing durability and economic production.

Fire resistance for 4 hours

Item	Hollow Block			
Length(mm)	400			
Width(mm)	100	150	200	250
Thickness(mm)	200	200	200	200
Weight of block (kg)	14	18	23	28
Blocks /m ²	12.5	12.5	12.5	12.5
Blocks/bundle	108	72	54	45



4.2 Solid Block

Transgulf's Solid blocks are standard structural masonry units with load bearing and non bearing capacity in compliance with international standard such as (ASTM, BS, BS EN, DM, and ADM etc) as per the project specification. We manufactured the units with different standard sizes in compliance with all quality procedure as per ISO standard 9001: 2008

Fire resistance for 6 hours

Item	Solid Block			
Length(mm)	400			
Width(mm)	100	150	200	250
Thickness(mm)	200	200	200	200
Weight of block (kg)	18	26	34	43
Blocks /m ²	12.5	12.5	12.5	12.5
Blocks/bundle	108	72	54	45



4.3 Hourdi Block

Our Hourdi masonry blocks are manufactured in compliance with the international standards and project specification. The units are suitable for a various climatic conditions and ideally used in the slab floor concrete, as a purpose of filler blocks.

Fire resistance for 4 hours

Item	Hourdi Block			
Length(mm)	420/380			
Width(mm)	200	240	250	300
Thickness(mm)	200	200	200	200
Weight of block (kg)	18	20	21	23
Blocks/bundle	54	45	45	36

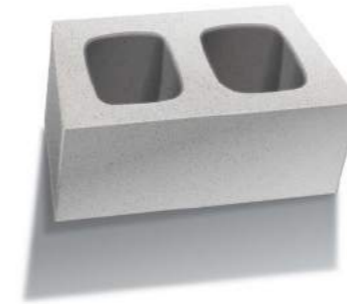

4.4 Thermo Block

Transgulf's Thermo Blocks are manufactured with different dimensions along with precise thermal insulation polystyrene insert embedded in the concrete which acts as an efficient thermal barrier and density in compliance with the standards which will provide cooling, save electricity, resist water, fire rating and comply with the thermal properties k, u and R values specified.

Fire resistance for 4 hours

Item	Thermo Block		
Length(mm)	400		
Width(mm)	200	250	300
Thickness(mm)	200	200	200
Weight of block (kg)	22	30	21
Blocks/m ²	12.5	12.5	12.5
Blocks/bundle	54	45	45



All our masonry products are in compliance with Quality Management system as per EN ISO 9001:2008

U. Value (thermal transmission) : 0.362 watt/m²°c

K. Value (thermal conductivity) : 0.0723 watt/m²°c

R. Value (thermal resistance) : 2.762 watt/m²°c

4

Retaining Wall Systems

4.5 Geoblock

Transgulf's Geoblock – our solid, top-pinning segmental retaining wall system – is a low-absorption, high-strength, solid concrete units ensuring the long-lasting durability engineers expect. The retaining wall system is ideal for use in residential, as well as commercial projects, adding a raw, natural, yet sophisticated feeling to location's low retaining walls, planter walls, tree rings and fire rings.

Geoblocks are subject to continuous research and testing in our facilities, ensuring stability, durability and exposure to different weather conditions. Our Geoblock is available in multiple colors, sizes and types, designed keeping in view the diverse demands from architects and engineers.

Item	Geo Block
Length(mm)	400/360
Width(mm)	100
Thickness(mm)	200
Weight of block (kg)	18
Blocks /m ²	12.5
Blocks/bundle	108

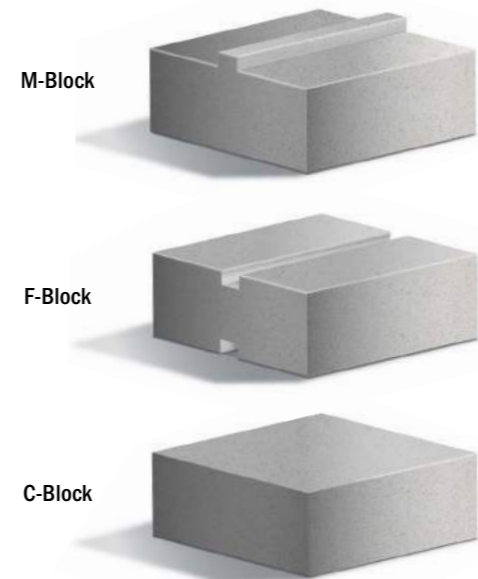

4.6 Dwell Block

Our Dwell blocks bring life to residential and commercial gardens, parks and planters, with an attractive decorative walling. It combines the durability and strength with the lush beauty of a hanging garden. Inside each unit, there is a plantable core for planting and a groove in the top to accommodate irrigation tubing. The result is a beautiful yet functional wall that becomes a living part of your garden landscape.

Item	Dwell
Length(mm)	400
Width(mm)	200
Thickness(mm)	167
Weight of block (kg)	20
Blocks /m ²	15
Blocks/bundle	72





5 PRECAST

The historic process of using concrete material and pouring it into the moulds to build complicated network of water tracks and tunnels could have only been turned into an efficient and effective process, using machinery to create complex structures to be used in architecture.

Transgulf is proud to have specialty in precasting concrete. Our high capacity equipments are more than capable of producing many different types of architectural applications in different shapes, sizes and functions depending on the requirements of our clients, from concrete seating to simply adding design elements to a site. Transgulf ensures great control in the quality of material used, as well as the artistry of the structure or shape of the concrete.



www.tgcp.ae

5

PRECAST CONCRETE PRODUCTS

Manufacturers of specialized architectural, structural precast products with vast finishes textured and colored concrete products from structures to furnitures with high quality and innovative design products. "TGCP" pledges, its best efforts to meet our client's desires for all prestigious projects with an exceptional quality and detailed drawing within fixed time frame.

HARD SCAPE PRODUCTS:

TGCP's vast experience in hard scape industry has been instrumental in successfully completing major projects across UAE. In the field of architectural excellence, we are known for the best; bringing our ingenuity with expertise by experienced teams of engineering.

ARCHITECTURAL HARDSCAPE

Rapid advances in technology are revolutionizing the hard scape industry, including the end to end application of architectural information and modeling and rapid adoption in our products and modular solution in our products.

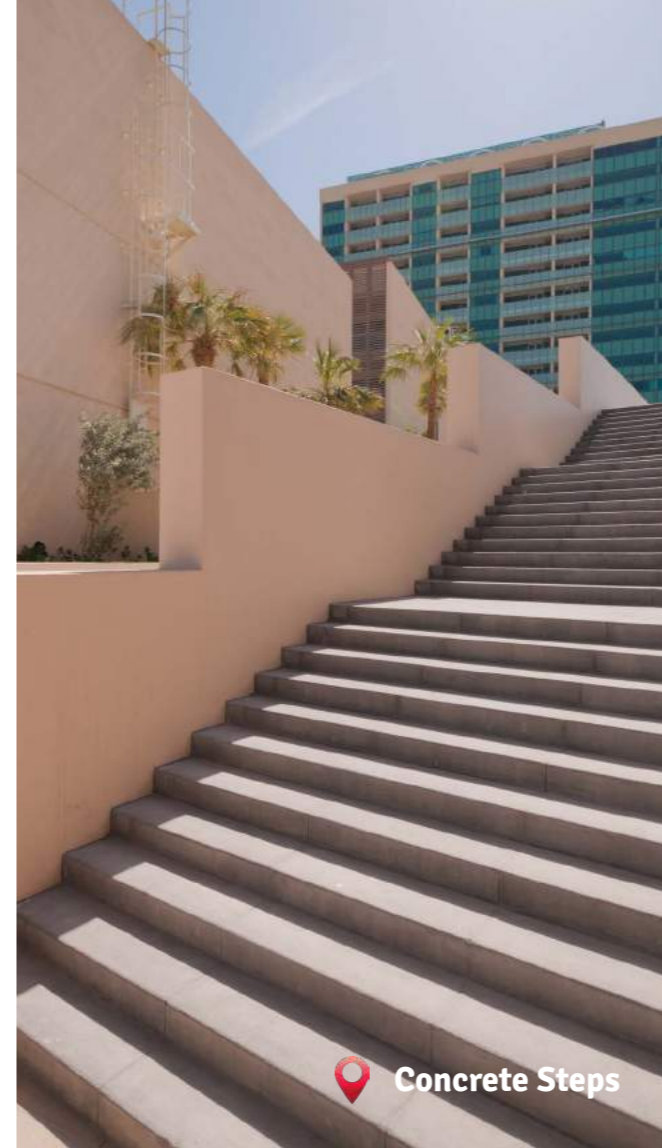

Concrete Steps



Tree Planters



AL Ain Stadium



Tree Grate

5

PRECAST CONCRETE MANUFACTURING

The modern challenges of construction, the combination of more knowledgeable clients and developers, poor quality of traditional methods and deteriorating skill shortages denotes that the precast industry has reached a critical level. With an innovative step to change the productivity to reach high quality, offsite and modular techniques offer a realistic solution to problem.

DESIGN & PRODUCTION

With our innovative creative design and production we are leading, a step ahead in increased productivity in construction processes and quality improvement in a most economical way. As a result, more client organizations are demanding for more innovative building techniques that are safer, cleaner and more efficient and; which minimize pollution with guaranteed quality, cost and time bound.

Working with government and private sector clients and the architecture, design and delivery supply chain; we are driving for value based agenda to be more widely achieved and stressed, creating mechanisms which will enable unique designs to compete with high class standard.

MANUFACTURING CAPABILITIES

TGCP's manufacturing solutions are transforming traditional construction methods into a modern process of elements. Our capability provides structural and hard scape elements.

THE SOCIAL GREEN ENVIRONMENT AND ECONOMIC BENEFITS

- Safer & cleaner delivery with specialized health & safety performance at the factory.
- Higher production with guaranteed quality in achieving the final product.
- Speed advanced projects delivered before the due time frame, enabling an earlier return on investments, an extensive range of interior or exterior options ensure complete design variation. Modern innovative technologies are adopted to achieve more precise quality. Creating sustainability through thermal & environmental performance, lower operational maintenance cost & with minimal industrial waste.

LIST OF PRECAST PRODUCTS:

- | | |
|----------------|---|
| • Planter | • Manhole |
| • Tree Grate | • Foundation blocks, |
| • Litter Bin | • Road new jersey barriers |
| • Re-cycle bin | • Boundary wall architectural textured and colored. |
| • Bollards | • Architectural coping |
| • Bicycle rack | • Sustainable ECO-paver |
| • Benches | • Deco deck decking units |
| • Tables | • GRC indoor and outdoor |
| • Drain cover | |

OUR PRECAST PRODUCTS:



Bench

Bench



Planters

Bollard

Bollard

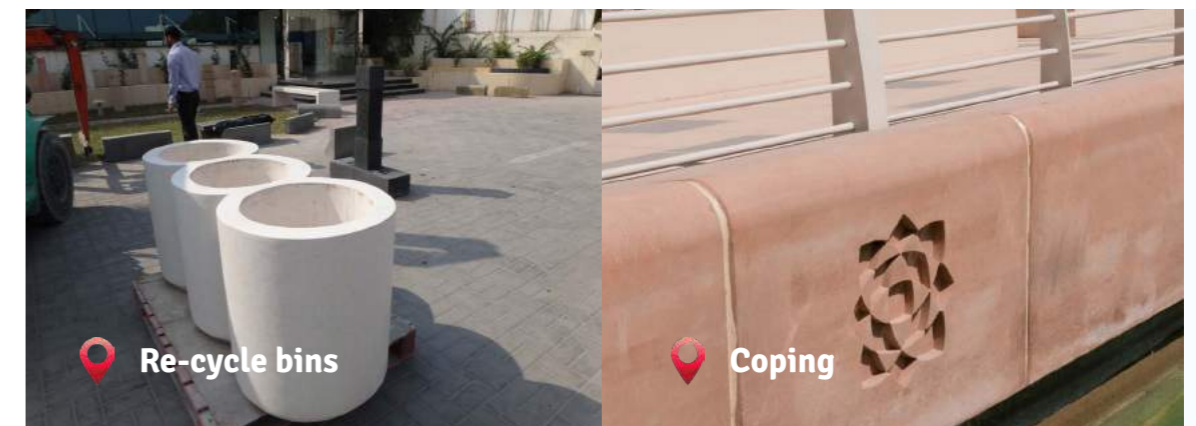

Re-cycle bins

Coping



Garden Table

Security Bollard

Drain Cover

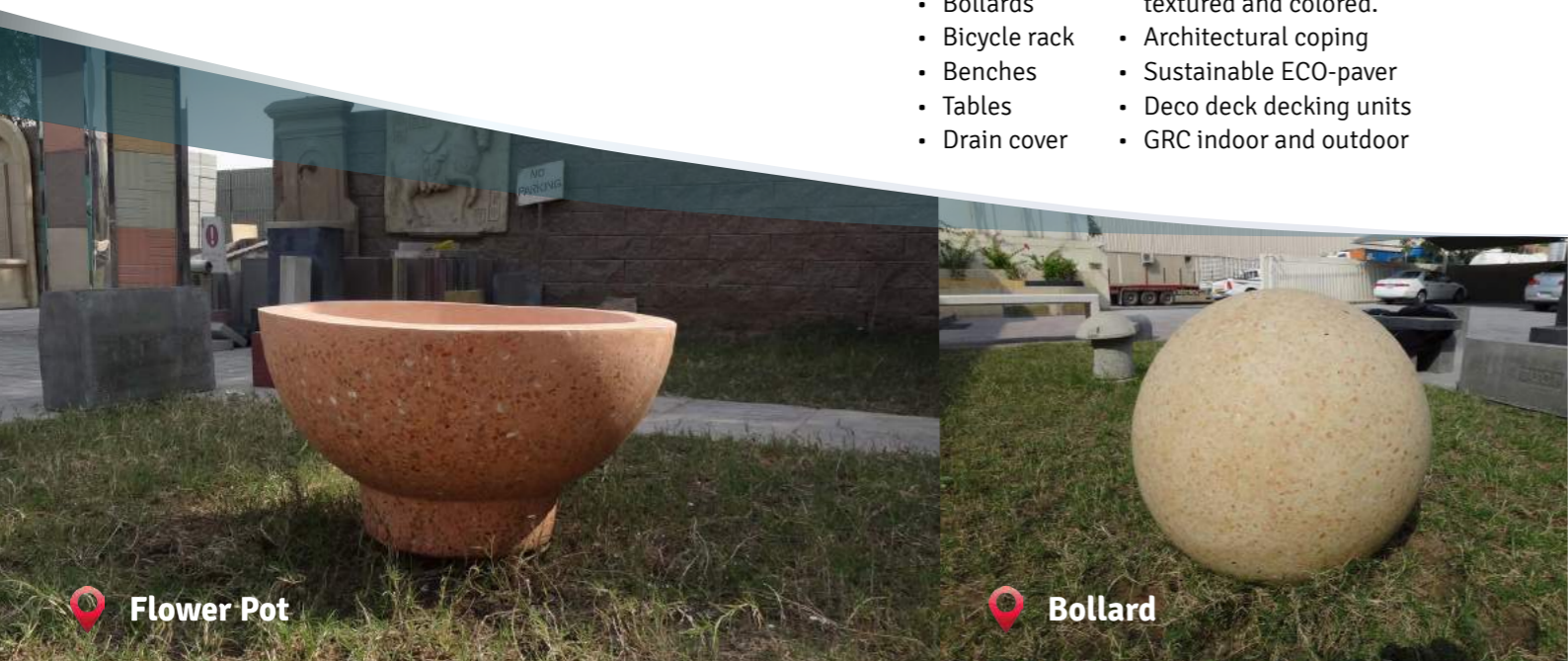

Flower Pot

Bollard



6

IMPORTANT INFORMATION



www.tgcp.ae

6

IMPORTANT INFORMATION

HEALTH AND SAFETY

Care should be taken when handling and installing TRANSGULF CEMENT PRODUCTS. Units weighing 20kg or more should ideally be handled mechanically, or by two or more persons if the process of carrying is repetitive.

DELIVERY AND STORAGE

TGCP are normally delivered to sites, properly packed on crane-offload road vehicles. Upon special request, packs can also be delivered shrink-wrapped and/or palletized to aid subsequent site movement activities. After delivery, the customer is solely responsible to ensure all packaging is carefully disposed off in accordance with the local environmental laws.

Delivered products should be stacked at a planned location on the site to avoid the double handling. Bundles should be stacked onto a prepared, clean area to minimize soiling and damage. It is highly recommended that the products are kept at a distant location, away from passing vehicles and pedestrians.

EFFLORESCENCE

All concrete products may, in their early life, appear to lose some intensity of color and experience a white stain on the face of the product. This phenomenon is known as efflorescence, it is a temporary phenomenon and stains will generally clear within a period of time. This is not detrimental to the product performance in any way and TGCP cannot be held responsible for its occurrence.

COLOR VARIATION

Due to the phenomenon of different curing, slight color and shade variation do occur on individual colored concrete products. Site conditions, seasonal manufacture, or naturally occurring variations in the aggregates used, can also cause variations. This is generally considered to enhance the natural stone effect and the colors will invariably wither in time.

MAINTENANCE

It is recommended that the paving materials are cleaned 2-3 times in a year to maintain appearance. Products which are paved on driveway, particularly of light colors, require more maintenance as the tire mark and oil leakage can diminish the appearance. It is recommended to clean using normal water with a soft brush, high pressure jet pumps should not be used. Power washing is to be avoided completely.

ORDERING

To avoid shortage, wastage of material, please double check the order quantity as TGCP LLC will neither be responsible for extra material nor the duration to deliver the shortage material. To avoid any confusion with respect to ordering, it is suggested that the paving tiles are ordered as a total batch and drawn out from several packs at the same time, to enhance any color variation. We recommend that colors are chosen from actual materials rather than color photographs herein.

WEATHERING

All concrete products will wither and change, especially after a period of time with exposition to natural elements.

SIZES

TRANSGULF's paving is manufactured to capture the authenticity of natural stone and as such, they do vary in thickness. All sizes are nominal and customers are advised to check with their supplier. Bulging can occur on larger individual pavers as a natural result of shrinkage. This does not alter the durability of the product.

LIABILITY

Liability in respect of any statements, conditions, warranties and representations made on behalf of the company, TRANSGULF CEMENT PRODUCTS LLC cannot accept liability for any loss, damage or injuring sustained as a result of following it. We will not take any responsibility or liability if products are being used for purposes other than those for which they are intended for by the manufacturers. Due to our continuous evolution of product design and improvement, our range is subject to change without prior notice. Customers are advised to ensure that the stated information is up to date.

PRODUCT UNSATISFACTORY CONDITION

In case a product is delivered in an unsatisfactory condition, and other than any natural occurring one as described, the defect would have to be informed about apparent prior to laying. It is at this point that the supplier should be notified of such a fault, and allowed time for the rejected product to be replaced. If the complaint is raised after laying the product, no responsibility will be accepted for any relaying or removing costs.

Product Standards

ALL "TRANSGULF CEMENT PRODUCTS L.L.C" PRODUCTS ARE MANUFACTURED TO THE APPROPRIATE INTERNATIONAL STANDARD WHERE APPLICABLE.



Transgulf Cement Products L.L.C.
عبر الخليج للمنتجات الإسمنتية ذ.م.م.

Dubai office:

Jebel Ali Ind. Area
P.O. Box 25595, Dubai, U.A.E
Tel : +971 4 8801020
Fax : +971 4 8801021
Email : info@tgcp.ae
Web : www.tgcp.ae

Abu Dhabi office:

P.O. Box 131329, Abu Dhabi, U.A.E
Tel : +971 2 6797959
Fax : +971 2 6797960
Email : info@tgcp.ae
Web : www.tgcp.ae