

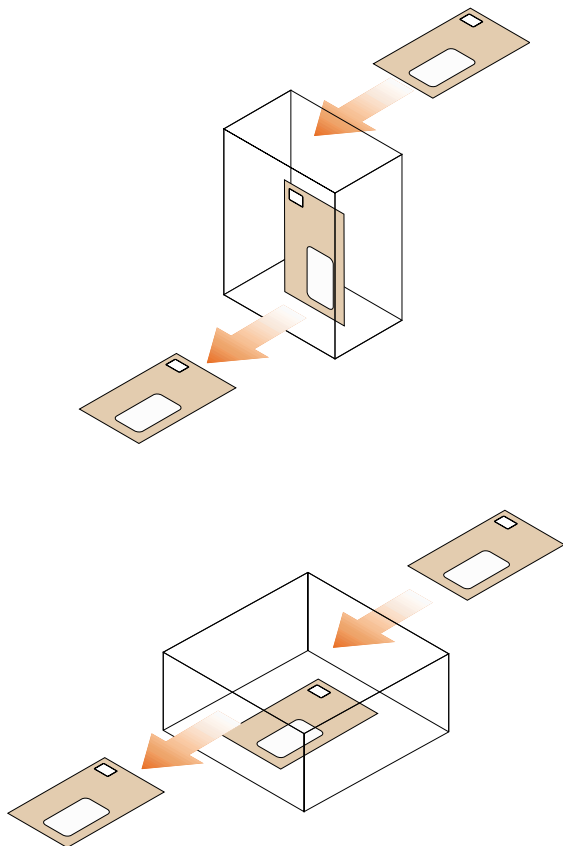

In Back/Out Front Range



This range of products is designed to receive the mail through the back of the mailbox. The mailbox holds the mail which is then accessed by opening the lockable door on the inside face.

Ideal for mounting onto the inside surface of an exterior door, boundary wall or fence where the postman cannot gain access to the actual building or site, or when banked together to form a sorting facility.

The Homeguard range was the first mailbox produced by the Safety Letterbox Company. The unit was originally designed to fit onto the inside face of a domestic front door and contain not just the mail but also dangerous unwanted materials such as burning rags, fireworks etc. The mailbox therefore was classed as a safety device and these unique features gave rise to the company name – The Safety Letterbox Company.



The Post Office Boxes are ideal for apartment blocks, reception areas or to create a boundary wall in an office space where mail is received in bulk and distributed into the mailboxes by internal staff.

- Manufactured from aluminium extrusion. Polyester powder coated to a choice of colours from our standard range
- Suitable for domestic and commercial use
- For interior application
- Large range of sizes available
- Large number of units can be accommodated per sq meter
- Can be manufactured in banks to suit required configuration and client requirements
- Totally secure locked front doors
- Vandal resistant

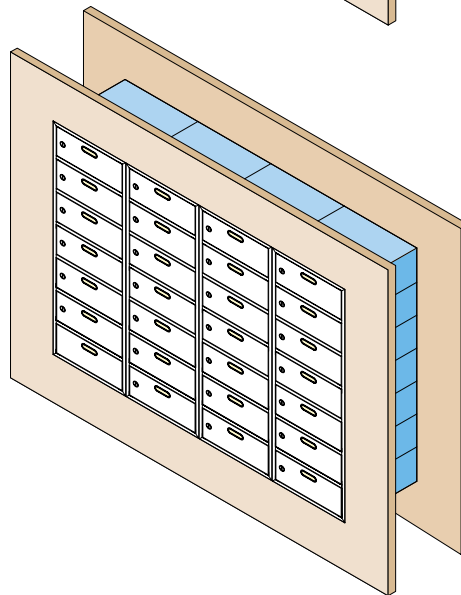
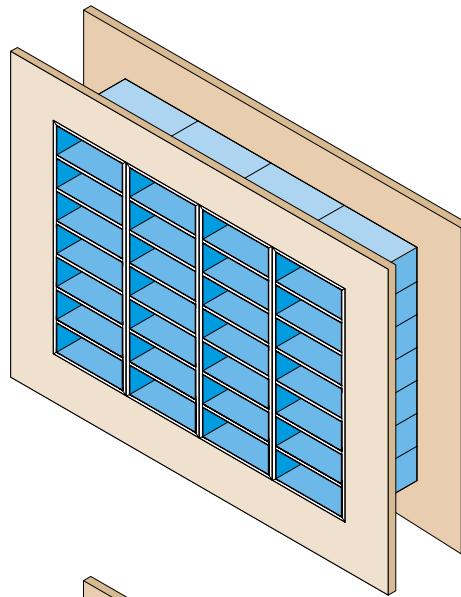

Fence Mounted – Vertical

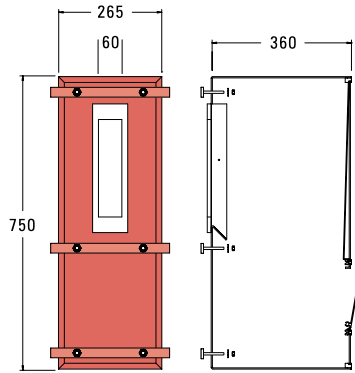
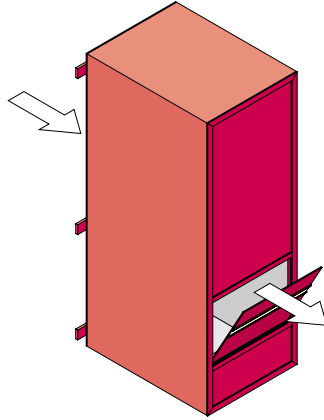

These mailboxes are supplied with clamping plates and fasteners enabling them to be fitted to a fence or steel railings.

As the flap and railings are vertical, it is only necessary to align the flap in the gap between the railings, providing this gap is not less than 60mm.

- Manufactured from aluminium extrusion. Polyester powder coated to a choice of colours from our standard range
- Suitable for domestic and commercial use
- For exterior application
- Receives A4 size mail but can be produced to receive A3 size
- Large capacity
- Easy to fit
- Weather and vandal resistant

Railings height must be at least 750mm to allow mail to be inserted and retrieved

Fence Mounted – Horizontal

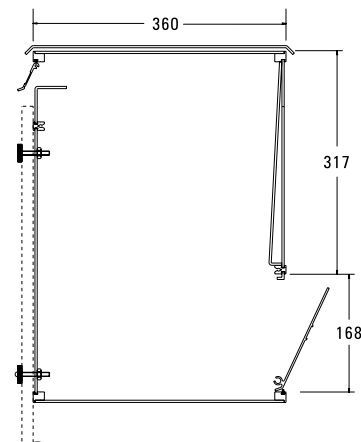
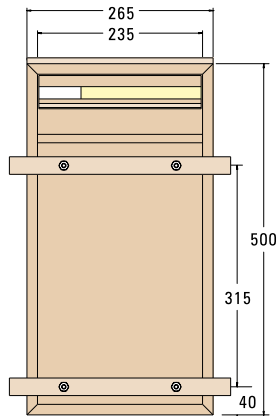

Horizontal mailboxes have a large capacity but are not as tall as the vertical boxes shown above. Supplied with clamping plates and fasteners enabling them to be fitted to a fence or steel railings.

- Manufactured from aluminium extrusion. Polyester powder coated to a choice of colours from our standard range
- Suitable for domestic and commercial use
- For exterior application
- Receives A4 size mail but can be produced to receive A3 size
- Large capacity
- Easy to fit
- Weather and vandal resistant

If fitted to vertical railings they would need to be cut local to the flap area

Homeguard

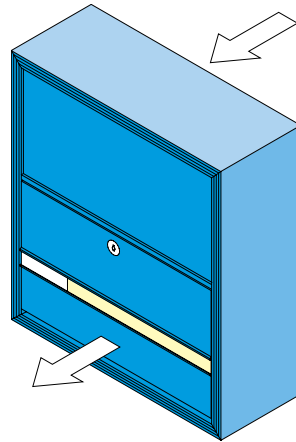

Front view

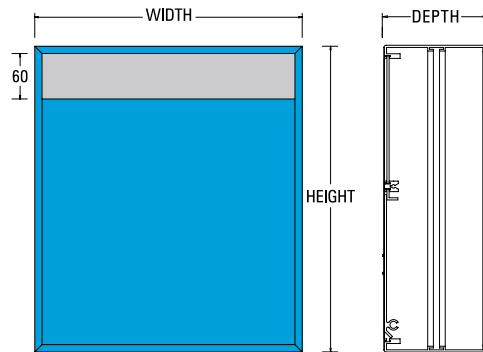

Rear view

Side view

Homeguard is an elegant unit designed to withstand considerable abuse and unwanted materials such as burning rags and fireworks.

- Manufactured from aluminium extrusion. Polyester powder coated to a choice of colours from our standard range
- Suitable for domestic and commercial use depending on size
- For interior application
- Single unit weight 3.5k
- Range of standard sizes available
- Robust welded construction for added strength
- Best suitable as surface mounted
- Can be fitted with fire extinguisher
- Letterplates can be supplied as an additional extra
- Vandal resistant

Model	Height	Width	Depth	APERTURE SIZE	
				Width	Height
D4	400	260	120	240	60
C3	400	300	120	280	60
C5	500	350	120	330	75
C7	500	350	240	320	75

THE SAFETY
LETTERBOX
COMPANY LTD

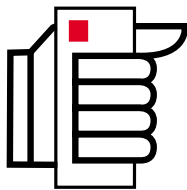

**The Safety Letterbox Company
Unit 1B, Milland Industrial Estate
Milland Road,
Neath SA11 1NJ**

Telephone: (01639) 633525

Facsimile: (01639) 646359

Web: www.safetyletterbox.com

Whilst all reasonable care has been taken in the preparation of this literature, all recommendations or suggestions regarding the use and application of products are made without guarantee, since conditions of use are beyond our control. Owing to a policy of constant improvement, information herein is subject to change without notice.

© The Safety Letterbox Company Ltd. 2005.
No part of this literature may be reproduced without the permission of The Safety Letterbox Company Ltd.