



Specials, Bespoke and Creative Range

As a result of unusual demand and experiences in the market place, special products have been created to combat a variety of difficulties.

As more difficulties and problems present themselves, so more imaginative solutions continue to be sought and in turn provided by the Safety Letterbox Company.

Each unit is designed and manufactured to meet specific client requirements and needs by working in partnership with the client to provide a unique and successful solution.

Our dedication to research and development together with our 'partnership' approach to working with our customers means that we are able to provide mailbox solutions in a variety of shapes, sizes and finishes.

If you have a project which requires a bespoke unit then The Safety Letterbox Company will be able to help you to reach the perfect mailbox solution.

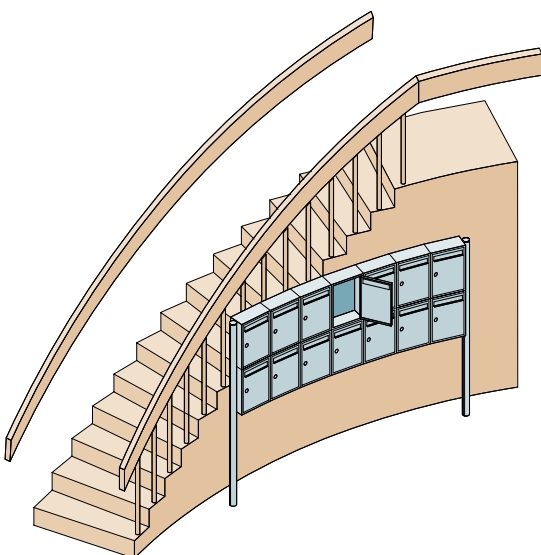

Key / Mail Boxes

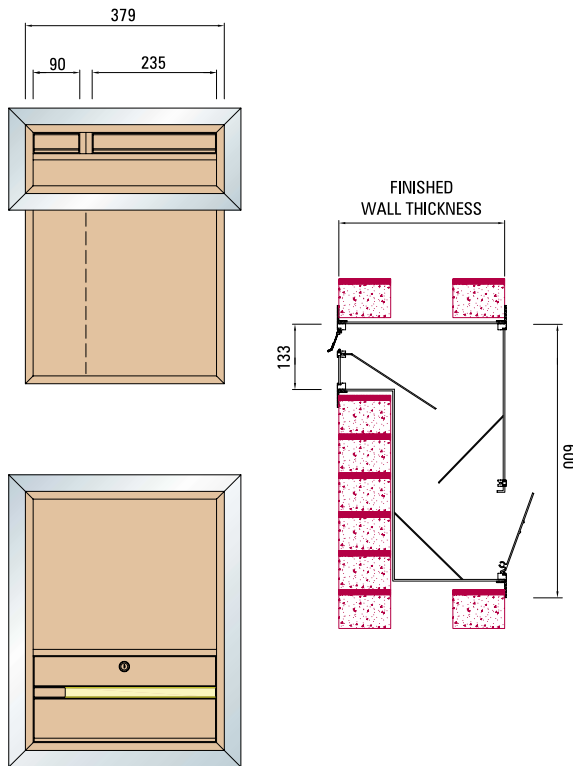

Designed to meet the specific needs of customers such as car hire or showroom companies who need a secure mailbox solution to accommodate the safe storage of returned sets of keys.

- Manufactured from aluminium extrusion. Polyester powder coated to a choice of colours from our standard range
- Suitable for commercial use
- For interior or exterior application
- Access door bridges both compartments
- Key aperture is kept as small as possible for added security
- Keys pass over steel baffles to avoid magnet attraction
- Suitable to be built into the brickwork
- Keys travel in a circuitous route to avoid illegal hooking from the mailbox
- Weather and vandal resistant

Repeat Prescription Mailboxes

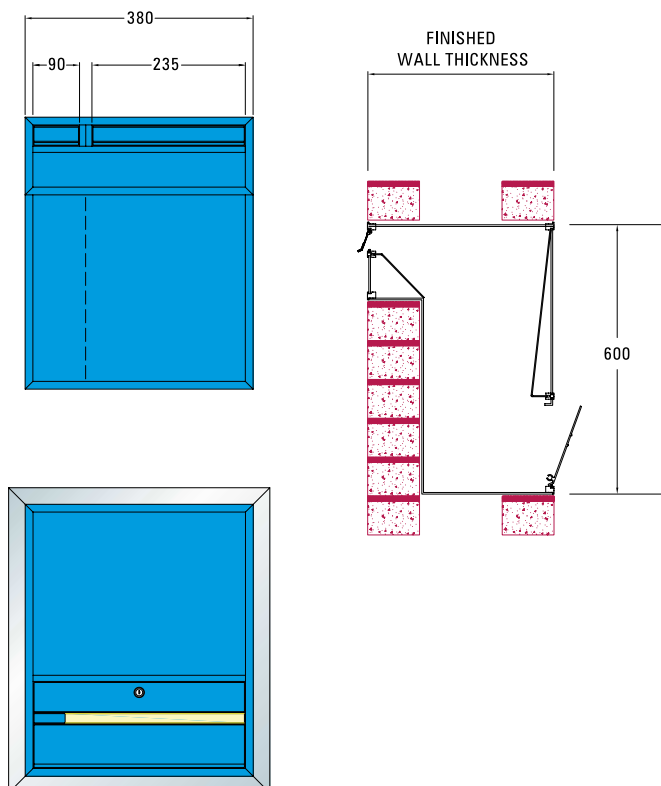

These units combine a mailbox compartment together with a smaller secure area for high volume mail e.g. repeat prescriptions. Enables the user to have easy access to prescriptions which have been posted by the patient.

- Manufactured from aluminium extrusion. Polyester powder coated to a choice of colours from our standard range
- Suitable for commercial use
- For interior application
- Access door bridges both compartments
- Suitable to be built into the brickwork
- Vandal resistant

Large Units



In certain circumstances a mailbox may be required to overcome a variety of problems.

We can create mailbox solutions which overcome a variety of problems including:

- Telescopic joints
- Inspection covers for easy access
- Anti-vandal mesh to protect from malicious liquids
- Removable wire basket for controlled sorting
- Drain off pipe to ensure any flammable substances are discharged clear of the mailbox
- Fire extinguishers
- High security hinges
- High security locking options

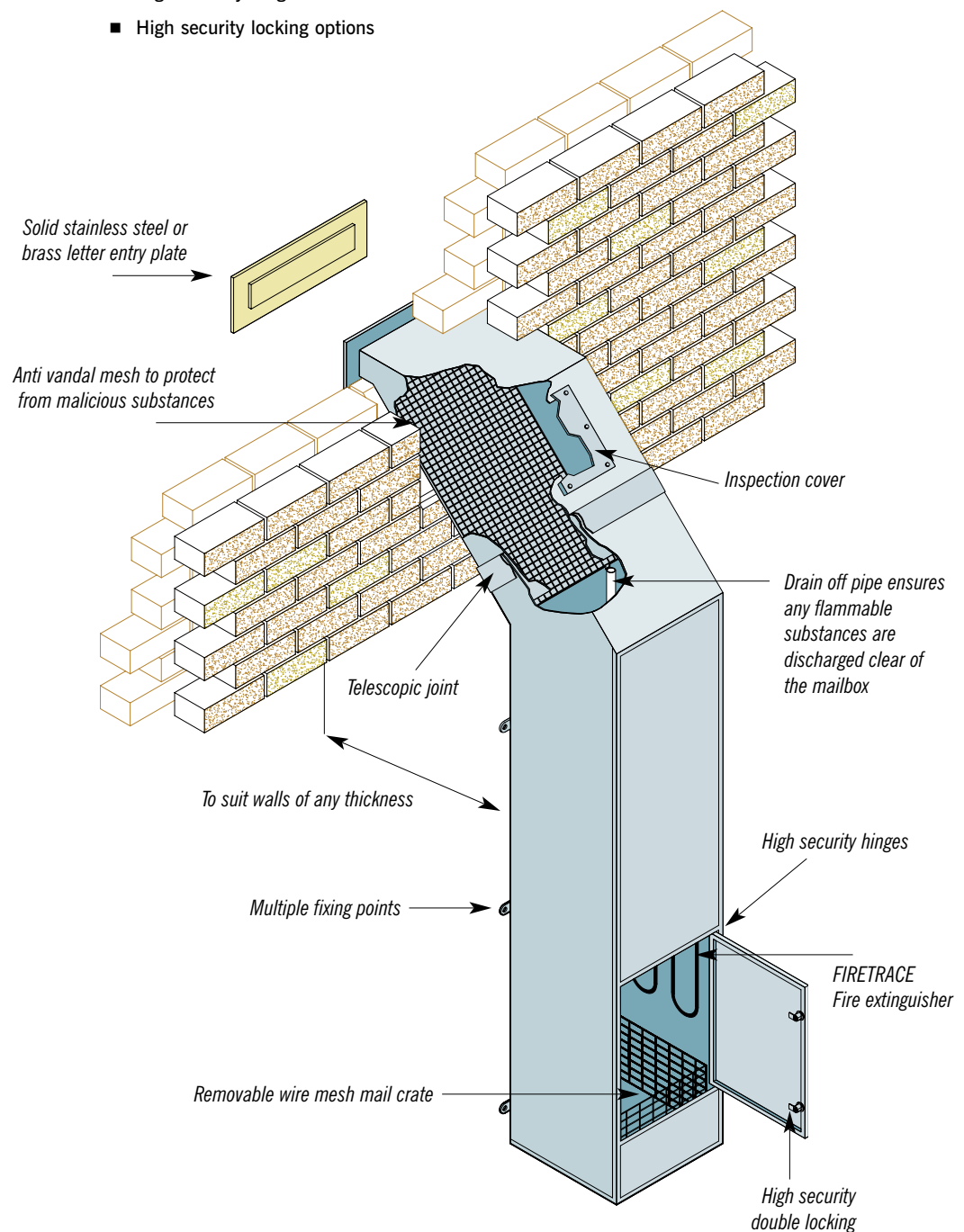

Bespoke Units

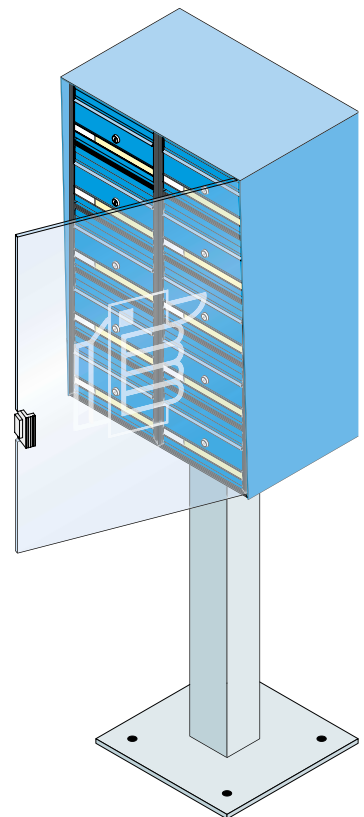
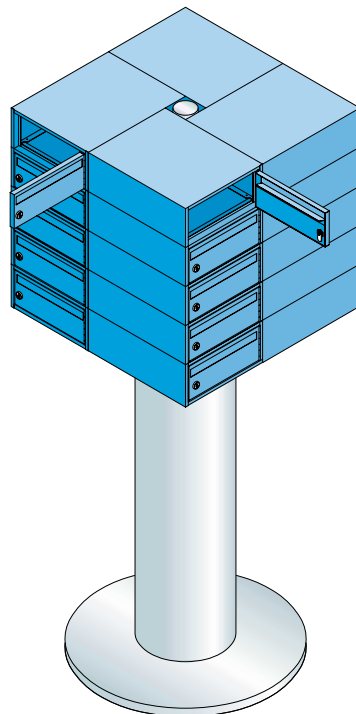

THE SAFETY
LETTERBOX
COMPANY LTD

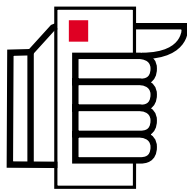

**The Safety Letterbox Company
Unit 1B, Milland Industrial Estate
Milland Road,
Neath SA11 1NJ**

Telephone: (01639) 633525

Facsimile: (01639) 646359

Web: www.safetyletterbox.com

Whilst all reasonable care has been taken in the preparation of this literature, all recommendations or suggestions regarding the use and application of products are made without guarantee, since conditions of use are beyond our control. Owing to a policy of constant improvement, information herein is subject to change without notice.

© The Safety Letterbox Company Ltd. 2005.
No part of this literature may be reproduced without the permission of The Safety Letterbox Company Ltd.