

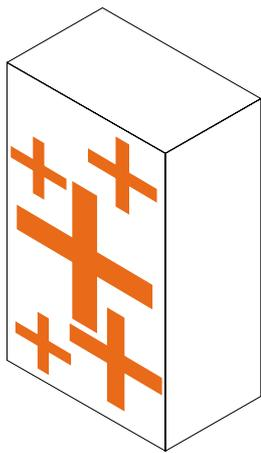

Accessories



The Safety Letterbox Company have created a variety of accessories which can be used with our range of mailboxes.

These range from support stands to weather shielding and locking options.

Some of our range of accessories are illustrated here but the list is not exhaustive.

Site conditions and/or aesthetics can dictate the requirement for an accessory to enhance the finish of the completed job.

The Safety Letterbox Company welcomes the opportunity to accommodate client requirements to create elegant solutions to infinitely variable site conditions.

Support Frames for Mailboxes

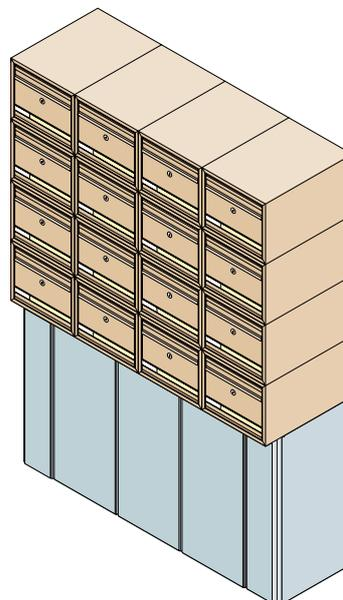
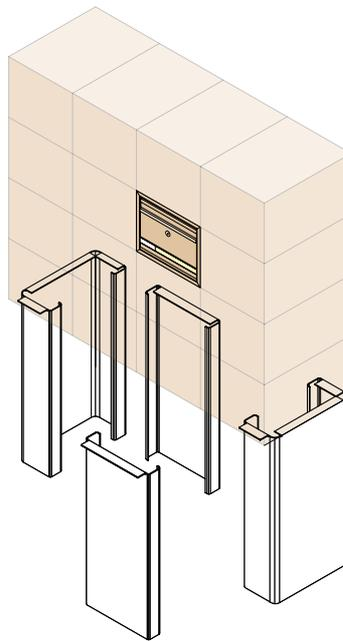

In many instances there is no space to house mailboxes on the wall surface, or indeed, anywhere in or on the building.

The only alternative therefore is to position the mailboxes alongside a pathway, in a car park or communally used approach way.

The mailboxes in this case, would be mounted with a freestanding support frame.

This section gives some standard alternatives but other options can be created if necessary.

- Manufactured from aluminium extrusion. Polyester powder coated to a choice of colours from our standard range
- Heavy duty models manufactured from 60mm dia steel. Polyester powder coated to a choice of colours from our standard range
- Stainless steel models manufactured from 60mm dia 316L Grade brushed finish stainless
- Flexible solution – can be used anywhere within the boundary of a property
- Frames are easy to assemble
- All fastenings are provided
- Support frames supplied disconnected from the actual mailboxes

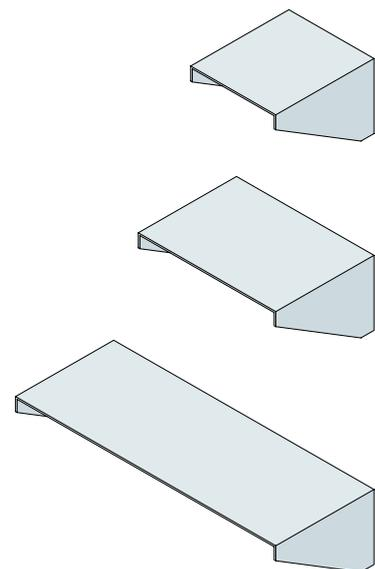

Cantilever support brackets

Locking Options

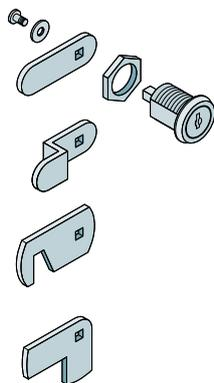

One point locking

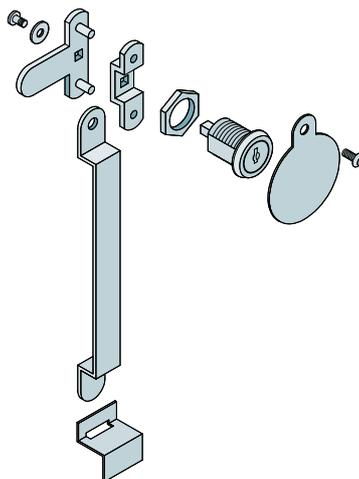
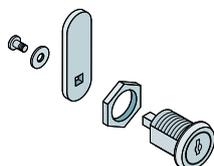

Two point locking

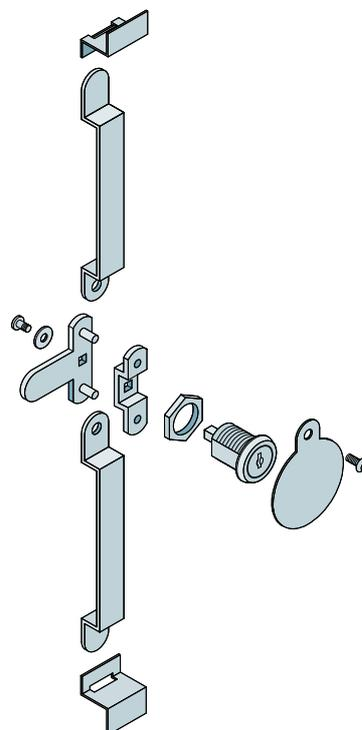
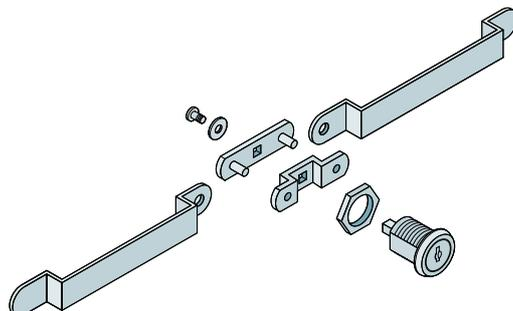

Three point locking

All mailboxes are fitted with a single disc tumbler lock as standard which provides a strong locking solution.

However, in exceptional circumstances, where the door size may be abnormally large, or, the level of security required is higher than normal, then a 2 point or even 3 point locking option can be made available to most of our range of mailboxes.

The locks have key numbers engraved on the front for ease of ordering spares.

Vision Panels

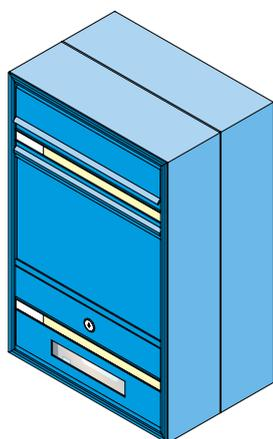

Vision panels to allow sight of the contents of the mailbox prior to opening can be made available for any of our mailbox range. The strong transparent material can be incorporated into mailbox doors and are held in position by internal fixings.

- Offers added security in hostile environments
- Strong polycarbonate material
- Shatterproof
- Weatherproof
- Vandal resistant

Weather Shielding

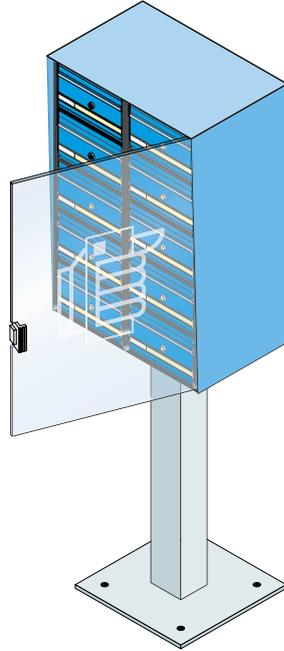

Weather shielding offers added protection against the elements where a support frame is situated in an exposed position.

- Manufactured from 1.5mm galvanised steel sheet. Polyester powder coated to a choice of colours from our standard range
- Easy to install as mailboxes are delivered complete with weather cladding
- Polycarbonate shields or polycarbonate doors with magnetic locks available for severe conditions



Light Fitting / Roof Options



By increasing the size and shape of the weather clad roof area, we can create sufficient space for the introduction of low voltage lighting which can be switched either manually or automatically.

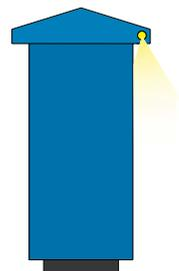
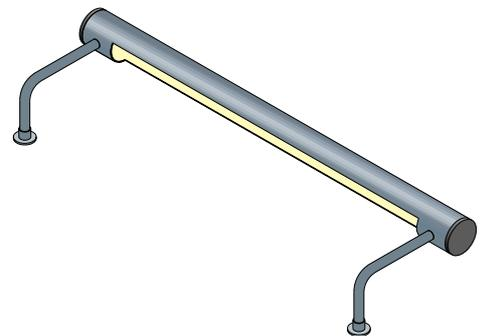
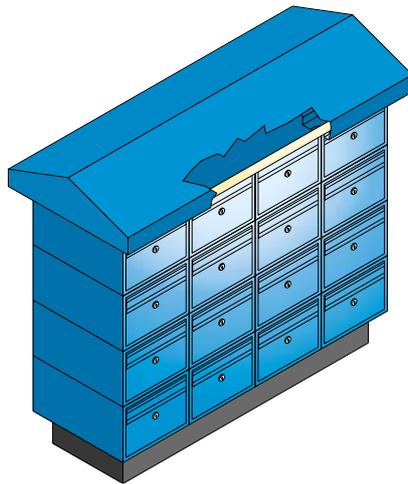

Fire Extinguishers



Where risk is considered high, mailboxes can be fitted with a fire extinguisher. Originally designed and created to protect racing car drivers from fire, 'pyroflex' is an unobtrusive tube which is fixed to the inside of the mailbox. In the event of fire, the heat generated softens the tube which punctures at the hottest point, (approx 80°) accurately releasing the gas into the seat of the fire which extinguishes the fire at source.

- Self-activating system
- Suitable for domestic and commercial use
- Inexpensive and easily replaced
- Lightweight and unobtrusive
- Mailboxes are supplied with extinguisher fitted
- Tube contains Dupont FE25 clean fire extinguishant gas which is environmentally friendly and complies with the current Montreal Protocol
- The system is unaffected by humidity, dirt or turbulent airflow
- Can also be fitted with alarm

Letterplates

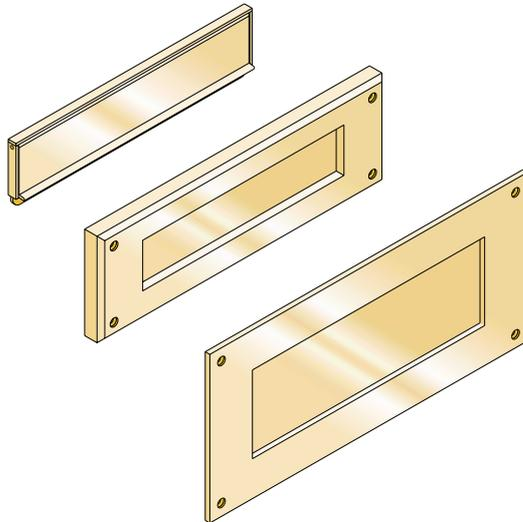

For many applications, standard proprietary letterplates are satisfactory. However, there are circumstances where the standard letterplate option is unacceptable because of limited size. In these circumstances we can produce a letterplate with a spring inward opening flap to any size.

These letterplates are particularly suited for use with Chuted 1, 2 and 3 mailboxes (see page 28-29).

- Can be manufactured in aluminium with a powder coated finish, solid polished stainless steel or solid polished brass
- Suitable to receive extra wide packages, e.g library books cassettes etc

Name Badges

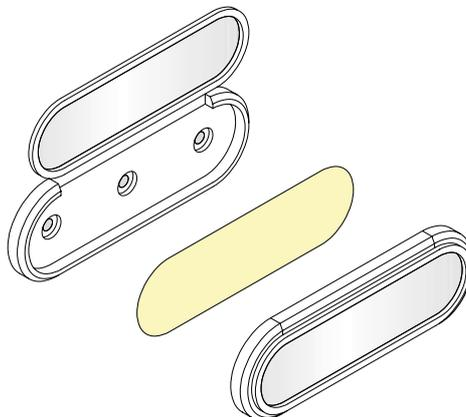

Name badges are a one piece flip open weather-proof name card holder.

They are supplied if alternative methods of engraving vinyl numbers/letters or our distinctive yellow and white name strip are not available or desired.

Door Entry Systems

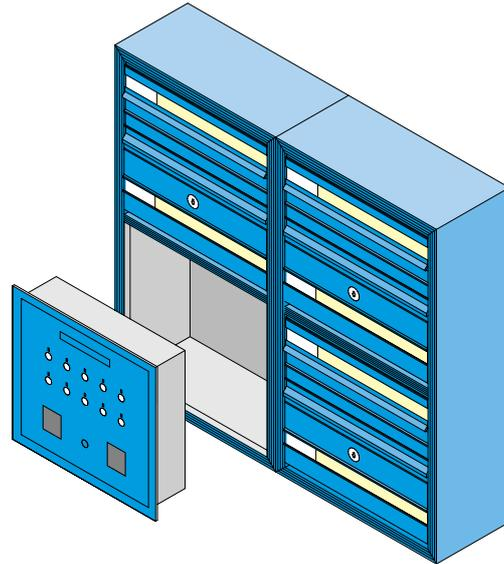

Where a door entry system and a mailing system is required at the same location, it can be convenient to house the door entry system within the mailbox system thereby saving space and cost and resulting in an aesthetically pleasing solution.

Most proprietary door entry systems can be accommodated within our mailboxes but the most space effective method would be to use our supplied components to create a system which is designed and sized to suit the mailbox.

As a result of the infinite variations of requirements, i.e. number of push buttons, audio and/or video requirements, door release systems etc, it is preferred that our technical sales team provide the customer with a drawing of the finished layout upon receipt of full specification and requirements.



Engraving



With our in-house CNC engraving facility, numbering and lettering in a wide range of fonts and sizes infilled in a variety of colours is available.

Mailbox flaps, bridges and doors can be engraved or additional nameplates can be incorporated in mailbox assemblies – all to individual customer requirements.

Complexity of detail required is no bar to engraving, and anything that can be drawn can be faithfully reproduced.

Flanges

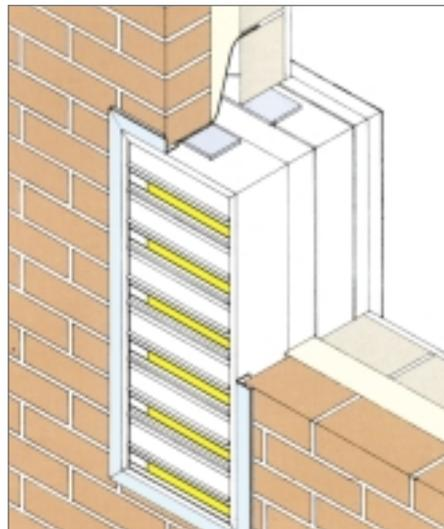

All mailboxes and most banks of mailboxes which are recessed, or built into a wall, can be supplied with surround flanges externally and internally.

The internal flange would be supplied loose fitting for subsequent fitting on site.

The internal flange could be substituted with softwood architrave which, depending on site conditions may be more flexible and convenient.

Collection Baskets

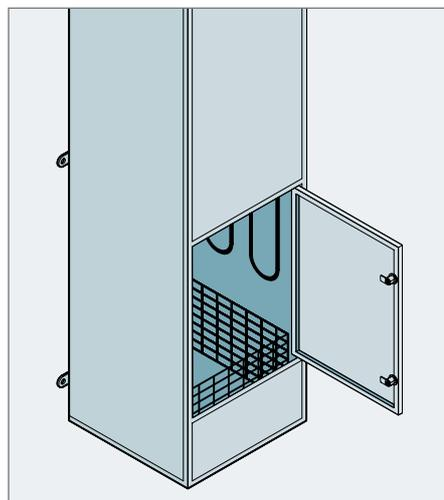

There is a danger, especially in some public buildings with large mailboxes, that harmful materials can be deposited into the mailbox.

In an attempt to reduce the risk to the individual accessing and sorting the mail, a mesh basket can be provided which can be lifted out and removed to a convenient area which enables the mail to be sorted in a safer environment.

Our range of mailboxes can be polyester powder coated to a choice of colours from our standard RAL range.

The material which we use is a high quality powder formulated to have excellent anti-graffiti and stain resistance properties with good aesthetic appearance.

Colours can also be matched to client requirements – please contact us for further details.

Anti Graffiti Powder Coating

All mailboxes can, in addition to the standard 'extra-life' coating, be further protected by an additional coat of 'anti-graffiti' lacquer.

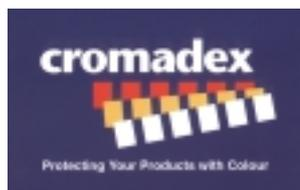

	Light ivory RAL 1015
	Melon yellow RAL 1028
	Carmine red RAL 3002
	Dark sapphire blue RAL 5003
	Gentian blue RAL 5010
	Dark cobalt blue RAL 5013
	Middle sky blue RAL 5015
	Moss green RAL 6005
	Anthracite grey RAL 7016
	Black grey RAL 7021
	Blue grey RAL 7031
	Agate grey RAL 7038
	Window grey RAL 7040
	Sepia brown RAL 8014
	Jet black RAL 9005
	Pure white RAL 9010
	Gold
	Silver
	Bronze
	Stainless steel

Due to the nature of the printing process, these colours are reproduced on this brochure as closely as possible to the final finish.

THE SAFETY
LETTERBOX
COMPANY LTD

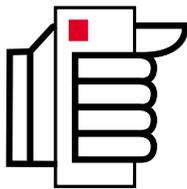

**The Safety Letterbox Company
Unit 1B, Milland Industrial Estate
Milland Road,
Neath SA11 1NJ**

Telephone: (01639) 633525

Facsimile: (01639) 646359

Web: www.safetyletterbox.com

Whilst all reasonable care has been taken in the preparation of this literature, all recommendations or suggestions regarding the use and application of products are made without guarantee, since conditions of use are beyond our control. Owing to a policy of constant improvement, information herein is subject to change without notice.

© The Safety Letterbox Company Ltd. 2005.
No part of this literature may be reproduced without the permission of The Safety Letterbox Company Ltd.