

# PLATE TYPE HEAT EXCHANGERS

## OPERATION & MAINTENANCE MANUAL



Project :

Customer :

Exchanger type :

Serial number :

Year :

PED category :  Art. 3, par.3       Cat. 1       Cat. 2       Cat. 3       Cat. 4

Approved by : NB number:

Remarks :

The contents of this publication are based on the latest information available and the materials that are used at the time of printing. However, because of rapid developments in this field we cannot be held liable for changes in specifications affecting the contents of this publication.

**COPYRIGHT**

Copyright © SONDEX HOLDING A/S. All rights reserved. No part of this publication may be reproduced or distributed without prior written permission of SONDEX HOLDING A/S.

## **1 FOREWORD**

This manual is a guide for installation, commissioning and maintenance of plate type heat exchangers supplied by SONDEX.

It is meant for those who are responsible for the installation, the use and maintenance of the heat exchangers. We recommend that you read this manual carefully before commencing any work.

## **2 INTRODUCTION**

This manual is applicable for all heat exchangers produced and supplied by SONDEX.

**SONDEX can not be held responsible or liable for damage as a result of incorrect installation, use and / or maintenance of SONDEX plate type heat exchanger as well as not complying with the instructions in this manual.**

**Please note that our plate type heat exchangers are specially designed and built for the operating conditions (pressures, temperatures, capacities and type of fluids) provided by the customer. Sudden pressure peaks beyond the normal operating pressure (or pressure surges) which can occur during starting up or stopping of the system can severely damage the heat exchanger and should be prevented. SONDEX can not be held responsible for any damage as a result of any operation deviating from the original design conditions.**

If you wish to alter the design conditions, please contact us refer page 24. You may only commission the heat exchanger under the modified conditions after inspection and written approval by SONDEX. Also the name plate on the heat exchanger will be adapted.

## **3 SAFETY ALERT NOTICES**

Refer to applicable SAFETY ALERT notices within the manual

All SAFETY ALERT notices are applicable to personal injury and identified by the following symbol.



## CONTENTS

- 1 FOREWORD**
- 2 INTRODUCTION**
- 3 SAFETY ALERT NOTICES**
- 4 GENERAL**
  - 4.1 Identification of the heat exchanger
  - 4.2 Correct operation
  - 4.3 Cautions
- 5 CONSTRUCTION**
  - 5.1 Frame
  - 5.2 Plates
  - 5.3 Gaskets
  - 5.4 Special executions
- 6 INSTALLATION**
  - 6.1 Requirements to the installation area
  - 6.2 Transport, lifting, storage
  - 6.3 Installing the pipe connections
- 7 COMMISSIONING / OPERATION**
  - 7.1 Commissioning and pre-checks
  - 7.2 Operation
  - 7.3 Shut-down for a short period
  - 7.4 Shut-down for a long period
- 8 MAINTENANCE**
  - 8.1 Clean in place (CIP)
  - 8.2 Some cleaning detergents
  - 8.3 Opening the heat exchanger
  - 8.4 Cleaning the plates
  - 8.5 Plate replacement
  - 8.6 Gasket replacement
  - 8.7 Tightening of the plate pack and pressure testing
  - 8.8 Maintenance of the heat exchanger
- 9 PROBLEM SOLVING**
- 10 AFTER SALES SERVICE**
  - 10.1 Ordering parts
  - 10.2 Modifications to the heat exchanger
  - 10.3 Contacts

4 GENERAL

4.1 Identification of the heat exchanger

All plate type heat exchangers supplied by SONDEX are provided with a name plate. On this plate the following details are specified:

- type of heat exchanger
- year of manufacture
- manufacturing number
- nominal capacity in kW
- transmission area in m<sup>2</sup>
- max. working pressure in bar
- test pressure in bar
- max. working temperature in °C
- min. assembling measure in mm

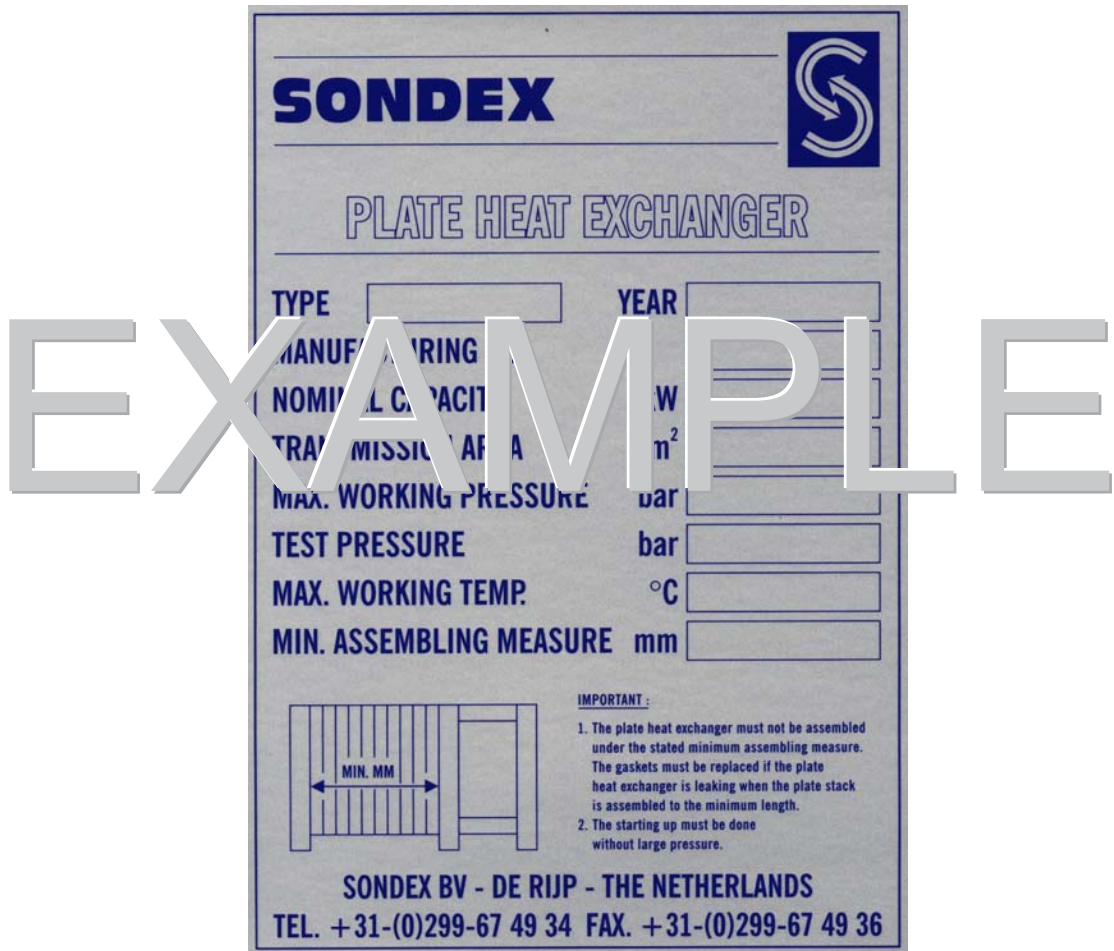

Fig. 1

## 4.2 Correct operation

**This user manual provides information and instructions for correct and safe operation of the unit. Many accidents are caused by incorrect use!**

**It is essential that you study the instructions carefully, and above all, ensure the availability to those who install, maintain and operate the apparatus on a daily basis. This manual will be of no value if it is not available at the time when your staff needs it.**

Should you have a problem with your SONDEX Heat Exchanger which is beyond the scope of this manual, do not hesitate to contact us. The installation should not be put into operation before all indistinctnesses have been solved!

To avoid injuries and damages, follow the instructions and local applicable safety regulations. Also take the necessary protective measures, depending on the nature of your process or circumstances related to it, at your plant.

Please note that our plate type heat exchangers are especially designed and built for the operating conditions (pressures, temperatures, capacities and type of fluids) provided by the customer. Sudden pressure peaks beyond the normal operating pressure (or pressure surges) which can occur during starting up or stopping of the system can severely damage the heat exchanger and should be prevented. SONDEX can not be held responsible for any damage as a result of any operation deviating from the original design conditions.

If you wish to alter the design conditions, please contact us. You may only commission the heat exchanger under the modified conditions after inspection and written approval by SONDEX. Also the name plate on the heat exchanger will be adapted.

## 4.3 Precautions – All potential personal injury hazards are identified by safety alert symbol.



Bodily harm can be caused by:

- burning as a result of touching the heat exchanger or other parts of the installation;
- the uncontrolled release of pressurized media with which the danger of burning and other injuries is present;
- contact with chemicals;
- touching sharp edges of the installation.

Damage to equipment can be caused by:

- external forces;
- corrosion;
- chemical action;
- erosion;
- weary;
- water hammer;
- thermal and / or mechanical shock
- freezing;
- wrong transport / lifting.

Even after stopping the installation some parts of it can still be hot!

The heat exchanger may only be used with the fluids specified on the datasheet.

The hot medium may not flow through the apparatus without the cold medium flowing through. This is to prevent damage to the apparatus.

In case the cold medium is present but does not flow while the hot medium is flowing through, the cold medium will start boiling and the apparatus will be damaged.

Sudden pressure and temperature changes should be prevented.

When a heat exchanger (filled with water or a water mixture) which is not in operation is exposed to temperatures below zero, the plates can become deformed. If a danger of frost occurs, the heat exchanger should be drained completely.

Demountable plate heat exchangers can always leak. We advise you to take this into account while installing. Preferably you should install a drip tray underneath the heat exchanger to prevent leakages onto the floor and/or danger to electrical equipment.

If the heat exchanger is being used with temperatures above 60° C or with aggressive fluids, we advise you shroud the heat exchanger to prevent the risk of touching.

If welding activities have to be carried out near the heat exchanger, never use the heat exchanger for earthing the construction work.

Electrical currents can cause severe damage to both plate and gasket.

If you have to weld, dismantle the connecting flanges and isolate the heat exchanger from the system.

## CONSTRUCTION

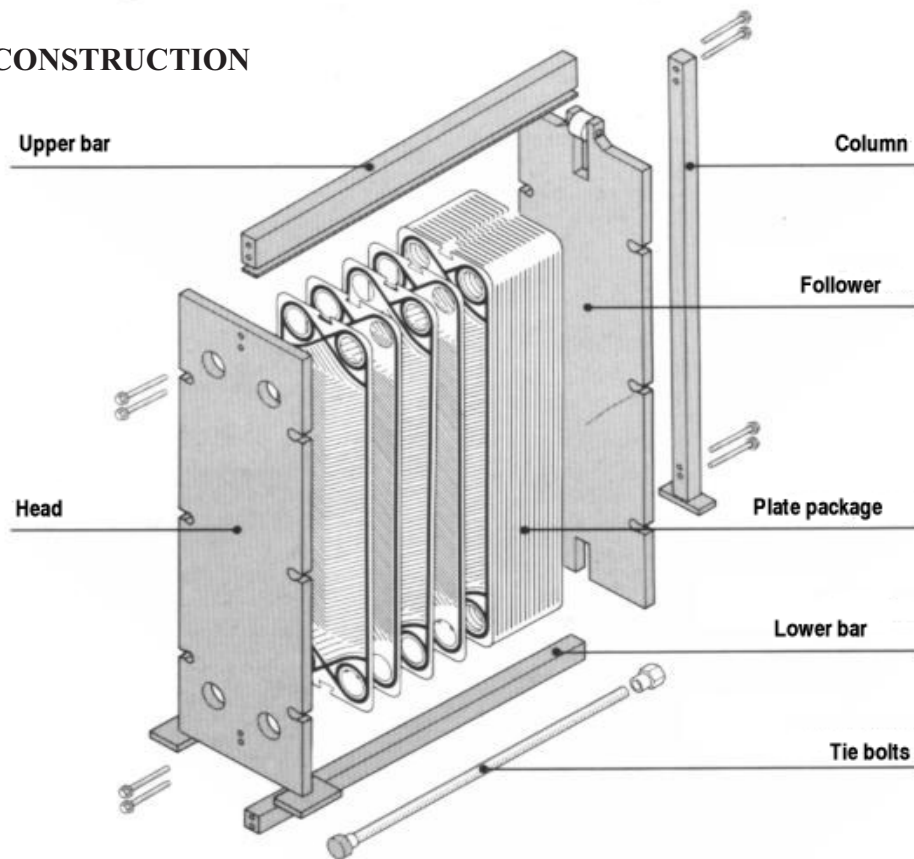

### 5.1 Frame

The heat exchanger consists of a frame plate (Head), a pressure plate (Follower), a carrying bar, a lower bar and a column. Tightening bolts are used to press the plates together. This is depending on the type of heat exchanger and can be different in some applications.



### 5.2 Plates

The plate package consists of plates with a groove along the rim of the plate and around the ports. The number of plates is, as well as size and dimension, dependant on the thermal output required. Depending on the application stainless steel or titanium plates might be used.

### 5.3 Gaskets

The groove provided in the plates holds the special gasket. The purpose of this gasket is to prevent intermixing of the media and leakage to the outside. The gaskets are selected to suit the actual combination of temperature, chemical environment and possible other conditions to be considered. They can be supplied in Viton, Nitrile or EPDM.



The following types of packings are being used in our plate type heat exchangers:

- Glue gaskets
- Clip-on gaskets
- "Sonder Lock" gaskets (new generation Clip-on gasket)



Clip-on gasket



Sonder Lock gasket

#### 5.4 Special applications

If the plate heat exchanger works with several fluids at the same time, it can be necessary to insert intermediate frames.

The intermediate frames are equipped with corner blocks, forming connections between the different sections. Two connections can be placed in the same corner block, having connection to two different sections in the plate heat exchanger.

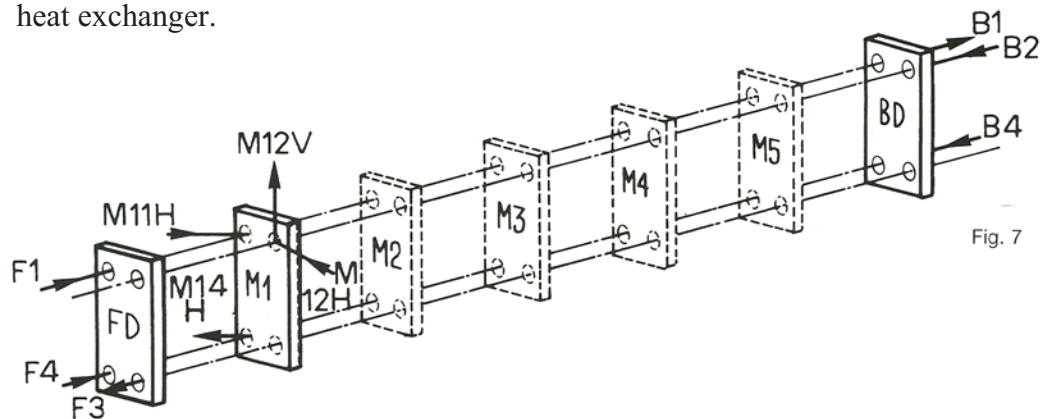
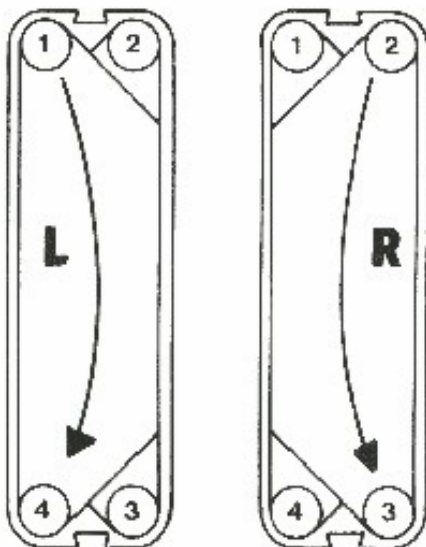

Fig. 7

For the exact application of your plate type heat exchanger please check the documentation which was supplied with the heat exchanger.



The SONDEX plates are designed in such a way that they can be used both as right and as left plates. The plates just have to be turned 180°. Right and left plates:

On a right plate the flow runs from hole 2 to hole 3 or reverse from hole 3 to hole 2.

On a left plate the flow runs from hole 1 to hole 4 or reverse from hole 4 to hole 1.

The opening of the corner holes are described in a "plate code index". For instance 1234 means that all corner holes are open.

Every plate can be identified by the packing configuration, the plate code index and thermal short or thermal long execution.

**Plate types:**



Start plate with gasket



Left hand flow plate with gasket



Right hand flow plate with gasket



End plate with gasket



Thermal long plate

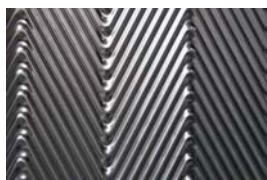

Thermal short plate

## 6 INSTALLATION

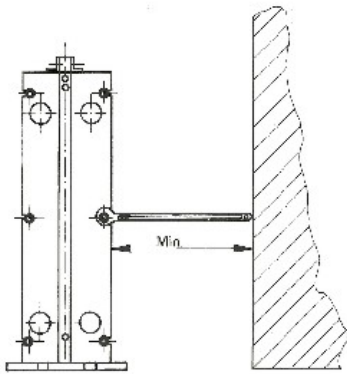

### 6.1 Requirements to the installation area

It is very important that enough space around the plate type heat exchanger is kept free for servicing of the unit (renewal of plates, tightening of the package).

As a rule the free space around the unit should be 1,5 to 2 x the width of the unit.

### 6.1 Transport, lifting and storage

Transport:

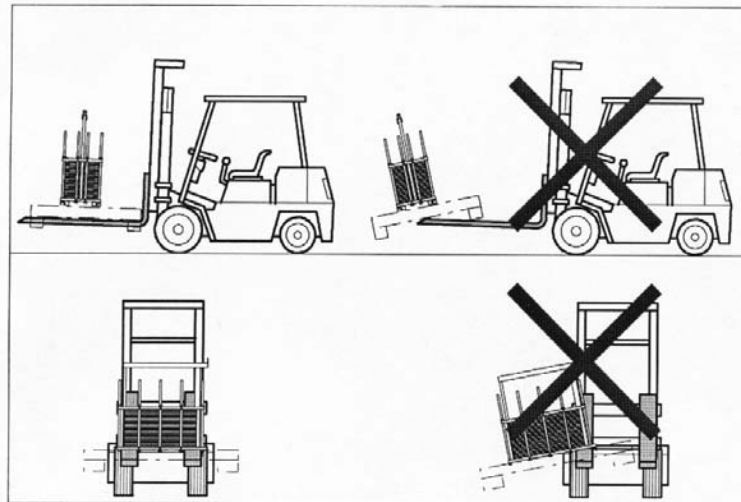

**WARNING:** To prevent personal injury always use appropriate hoisting equipment. If you are to lift the heat exchanger itself, straps should be used. They should be placed as shown on the picture.

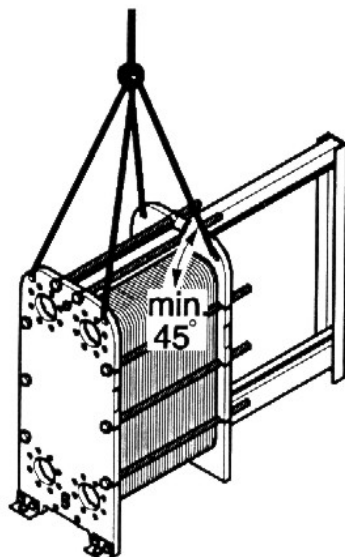

## Lifting:



Usually the heat exchanger will be supplied on a pallet. The back side of the head will then be tightened to the pallet. This allows you to transport the unit by means of a fork lift truck.

### Rising of the unit:

- Remove all tightening elements from the pallet;
- Place straps around one bolt on each side as shown on the picture. Never use steel cables or chains!
- Lift the heat exchanger from the pallet;
- Lower the heat exchanger slowly to horizontal and on its feet and place it in its end position on the floor.
- Remove the straps and tighten the heat exchanger to the floor.

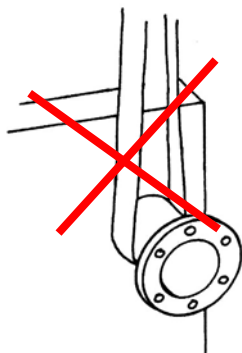

**Never lift the heat exchanger by using the connections or studs around them!**

### Attention:

**ALWAYS:** Use the lifting eyes (if fitted)

Lift the top side of the head

Attach the straps to the bolts close to the head

**NEVER:** Lift using the connections

Lift the follower

Lift using an intermediate plate

Lift with a strap attached close to the follower

## Storage:

Should it be necessary to store the heat exchanger for a longer period (1 month or more), certain precautions should be taken in order to prevent unnecessary damage to the equipment.

Preferably the heat exchanger should be stored inside in a room with a temperature around 15 to 20 °C and a humidity of max. 70%.

If this is not possible, place the heat exchanger in a wooden case which is provided with a lining on the inside against penetration of moisture.

There should **absolutely not** be any **ozone producing** equipment in the room, like electric motors or arc-welding equipment, since ozone destroys many rubber materials. Also do not store organic solvents or acids in the room and avoid heat or ultraviolet radiation.

## 6.2 Installing the pipe connections

Depending on the type the SONDEX plate type heat exchanger will be provided with flanges, couplings, threaded pipes, etc.

**When connecting the pipe system to the heat exchanger make sure that no stress or strain is imposed, by the pipe system, on to the heat exchanger!**

We advise you of the following:

- Heavy pipe work needs to be supported. This will prevent heavy forces onto the heat exchanger.
- Always install flexible connections on to the follower to prevent vibrations on to the heat exchanger. These flexible connections also prevent expansion of the pipe work, caused by temperature influence, onto the heat exchanger.
- These flexible connections need to be fitted in a longitudinal direction to the plate package.
- The pipe work needs to be thoroughly cleaned and flushed before connecting up to the heat exchanger.
- Always install vents on both sides of the heat exchanger.

Note: For proper venting the vents should be fitted on the highest point in the direction of the flow of the medium (preferably on an air vessel).

To enable the heat exchanger to be opened when necessary shut off valves should be provided in all connections!

**Make sure that the pipe work, connected to the heat exchanger, is secured against pressure peaks / surges and temperature shocks!**

Threaded pipe connections:

If a plate type heat exchanger is provided with threaded pipe connections make sure that these connections do not rotate when attaching unions or flanges. Rotation of the pipes could damage the gasket inside the unit which seals against the back of the pipe connection!

Flange connections:

If the connection is rubber lined, the liner will act as the flange gasket. Bolt the connecting flange directly to the endplate using the drilled and tapped holes provided. Tighten the bolts evenly – do not over-tighten as this could strip the threads cut into the frame plate.

If loose backing flanges are fitted to the heat exchanger a suitable gasket is required to seal the flange.

Unless otherwise stated, the liquid circuits should be connected to flow in reverse directions through the exchanger (counter-current). Refer to the contract drawing or quotation details if the connections are not marked.

## 7 COMMISSIONING

### 7.1 Commissioning and pre-checks

Commissioning may only be done by staff which has been trained specially for the job or by SONDEX commissioning engineers.

Control, maintenance and repair of the installation may only be done by authorized, trained and properly instructed staff.

Maintenance and cleaning may only be done with a shut down heat exchanger.

Check if all connections are fitted correctly (see also 6.3).

Filtration:

The media flowing through the heat exchanger should not contain particles larger than 0,5 mm diameter. If necessary filters should be fitted.

Check the pressures and temperatures of the media and make sure that these are not more than the values specified on the identification plate.

**It is essential that the heat exchanger is not subjected to thermal or mechanical shock as this could lead to premature gasket failure**

### 7.2 Operation

**Start cold circuit first, than the hot circuit.**

- Fully vent the system;
- Close isolation valves between pump and exchanger;
- Fully open valve fitted into return line from the exchanger;
- Start the circulation pump;
- **Gradually** open closed valve fitted to inlet line of exchanger;
- Vent system again if necessary.

Repeat the above for the secondary circuit.

When using steam as one of the media:

Use slow acting control valves and mechanisms only!

Before start up:

- Ensure that the steam control valve is fully closed
- Ensure that the heat exchanger is fully drained of condensate
- Start cold circuit first, then the steam side
- Open steam control valve slowly – this prevents water hammer of any condensate in the steam line and reduces the pressure / thermal shock to the exchanger
- Ensure that the steam trap is correctly sized to allow full condensate discharge – this prevents water clogging inside the exchanger

Check for proper operation:

- Check for pressure pulses in the system caused by the pumps or control valves. If found, stop operation and rectify. Continuous pressure pulses will result in fatigue failure of the plates.
- Visually check the unit for leakages.
- Check that all vents are closed to prevent air being sucked into the system.

**When in operation, the conditions should not be changed. The max. conditions specified on the identification name plate should not be exceeded.**

7.3 Shut-down for a short period

If the plate type heat exchanger has to be shut down for a short period, please follow the following procedure:

- **Slowly** close the control valve in the **hot** circuit whilst maintaining the full flow in the **cold** circuit;
- Switch off the hot circuit pump;
- Cool down the heat exchanger to the level of the cold medium;
- Slowly close the control valve in the cold circuit;
- Switch off the cold circuit pump;
- Close all remaining isolating valves.

7.4 Shut-down for a long period

If the unit is to be taken off line for an extended period of time then the following procedure can be followed:

- Allow unit to cool down;
- Drain all circuits;
- Lubricate tie bolts;
- Loosen tie bolts until the plate pack is “relaxed” (max. "a" size + 10%).
- The tie bolts should not be removed or loosened to such an extent that dirt is allowed to enter in-between the plates. We recommend that a warning notice is attached to the exchanger to remind personnel that the tie bolts need adjustment before the unit can be put back into service.
- Cover the plate pack with black plastic to exclude any sun light.

Please also see chapter 6.1 - Storage

## 8 MAINTENANCE

### 8.1 Clean in place (CIP)

#### **CIP cleaning (clean in place)**

To use CIP cleaning, it is a condition that the scaling on the plates is soluble. All materials in the whole circulation system of course have to be resistant to the cleaning detergent.

**We advise you to ask for a confirmation from the supplier of the cleaning detergent that it will not damage the materials in the heat exchanger.**

If the solution requires recirculation, select a flow that is as high as possible, and certainly no less than the service or product flows.

Follow the instructions as given by the detergent supplier / cleaning specialist. We suggest that for recirculated cleaning detergent methods, the fluid should be pumped through the exchanger for no less than 30 minutes.

#### Rinsing

**After using any type of cleaning agent, always rinse thoroughly with fresh water. If cleaning in place then circulate fresh water for at least 10 minutes.**

### 8.2 Some cleaning detergents

Oil and grease can be removed with a water emulsifying oil solvent i.e. BP system.

Organic and grease cover can be removed with sodium hydroxide (NaOH) maximum concentration 1,5% - max. temp. 85 °C.  
Mixture for 1,5% concentration = 5 ltr. 30% NaOH per 100 ltr. water.

Stone and limestone can be removed with nitric acid (HNO<sub>3</sub>) - max. concentration 1,5 % - max. temp. 65 °C.  
Mixture for 1,5% concentration = 2.4 ltr. HNO<sub>3</sub> 62% per 100 ltr. water.  
Nitric acid also has an affective build up effect on the passivation film of stainless steel!



**CAUTION:** Nitric acid and Sodium Hydroxide may cause injury to exposed skin, eyes, and mucous membranes. Use of protective eyewear and gloves is strongly recommended.



### 8.3 Opening the heat exchanger

When opening and assembling the heat exchanger observe the following:

- Measure and note the actual "a" size;
- Use the correct tools and lubricant;
- Shut down the heat exchanger as described under 7.3
- Make sure the heat exchanger cools down (<40 °C); with EPDM < 20 °C
- Ensure there is no pressure on any part of the unit;
- Clean the clamping bolts and grease them;
- Loosen the clamping bolts equally in the correct order (fig. 10) i.e. that the follower shall have a parallel opening motion.
- Pull the follower back towards the column.;
- Remove the plates without damaging the gaskets.

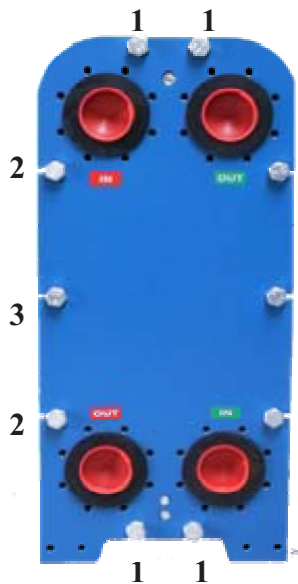

**CAUTION:** Ensure unit is depressurized and drained of hot and/or aggressive product before unit is opened to prevent personal injury



**CAUTION:** Sharp Edges. When handling plates, gloves should be worn.



#### **Recommendation:**

Mark the plate package before opening. You could mark the plate package with a diagonal line on the outside, or number the plates in sequence.

#### 8.4 Cleaning the plates



**CAUTION:** Always wear gloves and eye goggles when using detergents.

Use nylon or other types of “soft” scrubbing brushes with detergent.

***Never use a metal brush, steel wool or sand/glass paper. This will damage the passivation film of the plates.***

Use Acetone or other types of solvents which do not contain chlorine to remove old gasket glue. Alternatively use an LP gas flame heating the reverse side of the plate. Do not use any other type of gas which may produce a “harder” flame. Boiling water can be used with some success.

Consult a cleaning specialist for a suitable choice of detergent. Ensure that all detergents used are compatible with the plate and gasket material before use.

In case plates are removed for manual cleaning, make sure they are re-fitted in the same order.

**Always remove plates one by one and number them!**

A high pressure cleaner can be used but with absolute care and **never** add abrasives.

If the cover is thick from scale or organic material the plates can be put in a barrel with qualified cleaning material.

**Before fitting chemical cleaned plates they need to be thoroughly rinsed with fresh water!**

#### **Important:**

Cleaning is an important part, influencing the effectiveness of the plate heat exchanger. Insufficient cleaning can have the following results:

- too low circulation flow;
- insufficient thermal output;
- life time of the heat exchanger will be shortened.

**If a plate has to be renewed because of serious damage, one should make sure that the plates next to this plate are also being replaced.**

## 8.5 Plate replacement

The plates must be clean, dry and free from oil or grease. If there are any oil deposits on the gaskets, or on the gasket seating area, then there is a strong likelihood that the plates shall slip out of place when the unit is being tightened. If the gaskets are contaminated with dirt or grit, then these could cause leakage.

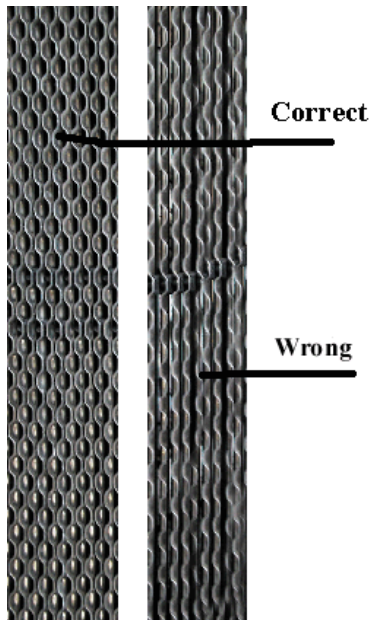

- make sure that all seating areas are flat, clean and undamaged.
- always use new gaskets.

Fit the plates according to the Plate Sequence Sheet – ensure all gaskets face towards the fixed / head frame plate.

Alternate between left and right handed plates – if the plate edges form a regular honeycomb pattern, the left / right hand sequence is correct, see fig.11.

Fig. 11

## 8.6 Packing replacement

### **Clip-on gaskets**

This type of gasket (Sonder Snap) and "Sonder Lock" (new generation glue free gasket) require no adhesive. They are located by pushing the gasket fully down into the gasket groove. The gaskets are held in place by the interference fit – narrowed portions of the gasket groove are pressed to ensure a secure fit. Make sure groove and gasket are clean!

### **Glue type gaskets**

The surfaces need to be clean and free of oil.

Only use chloride free glues like Pliobond 20 or 30, Bostic 1782, 3M EC 1099 and Bond Spray 77.

Follow the instructions of the manufacturer; these will be printed on the cover of the glue.



**CAUTION:** When using commercial solvents and adhesives, follow the manufacturers recommendations carefully, as many of these materials are hazardous.

### **O-rings**

Make sure that the flat side of the O-ring fits into the special packing groove of the plate. If the O-ring is not provided with a flat side the thinnest side of the O-ring needs to be fitted into the groove.

It can be necessary to use a little glue for positioning the O-ring during assembly of the heat exchanger.

### **Rubber liners**

On some model types, the rubber frame plate nozzle liners have an O-ring moulded into the liner itself. This moulded O-ring fits into the gasket groove in the first plate. Therefore, if new gaskets have been fitted, the O-ring portion of the gasket around the nozzle hole will have to be cut off prior to assembly back into the frame.

## 8.7 Tightening of the plate package and pressure testing

- Lightly oil the tie bolt threads. Do not allow oil or grease onto the gaskets or the gasket seating faces on the back of the plates. Wet or contaminated plates can become misaligned during tightening. In this case, dismantle, clean, and dry all areas in contact with the gaskets.

Evenly tighten all bolts in the correct order (refer page 17 fig. 10). We advise the use of ratchet spanners.

- Ensure clamping is as uniform as possible, thus keeping the frames and plates parallel throughout the operation. Avoid skewing the frame plates by more than 5 mm.
- Tightening is complete when the distance between the inside faces of both frame plates equals the “A” distance as shown on the contract drawing, see fig. 12.

This tightening distance can also be calculated using the following formula:

Assembly distance = No. of plates x (plate thickness + coefficient)

The coefficients vary depending on the model type. If in doubt, please check with the relevant SONDEX Sales Office.

- Finally check that all bolts are in tension and clean any spilt oil off the frame plates.
- On completion the unit can be pressure tested (test pressure is stated on the name plate).

Fig. 12

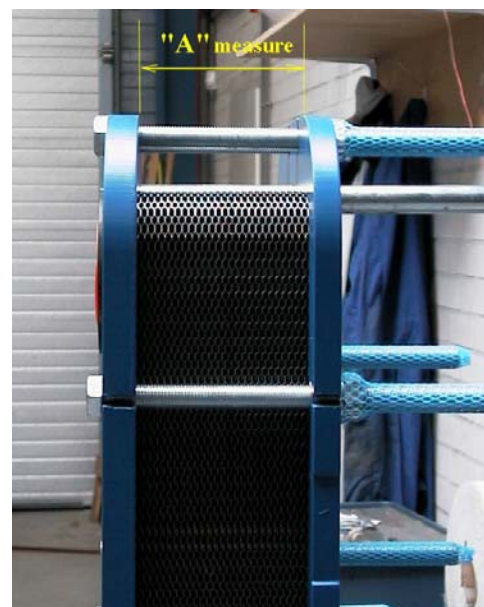

If dimension "A" is not reached with application of maximum tightening torque:

- check the number of plates and dimension A on the datasheet;
- check that all the nuts and bearing boxes are running freely. If not, clean and lubricate or replace.

If the unit does not fully seal, it may be tightened step by step to give dimension “A” **min**. This dimension is mentioned on the nameplate, see fig. 1. The maximum tightening torque must not, however, be exceeded.

**Under no circumstances distance “A” may be smaller than “A” min.**

**Tightening of the plate package can only be done with a fully depressurised unit.**

## 8.8 Maintenance of the heat exchanger

### **Time interval – once a year as a minimum**

Check temperatures and flows against commissioning data.

Check general condition and look for any signs of leakage.

Wipe clean all painted parts and check surfaces for signs of damage – “touch up” if necessary.

Check bolts and bars for rust and clean. Lightly coat threaded parts with molybdenum grease or a corrosion inhibitor (ensure that no grease, etc. falls onto the plate gaskets).

If rollers are fitted to the follower frame plate, lubricate the bearings with light machine oil.

## 9 PROBLEM SOLVING

If you have problems with your plate type heat exchanger, in most cases these can be solved by your own personnel.

Please find below a summary of possible problems as well as possible causes and solutions.

**A condition for the continuous proper functioning of your plate type heat exchanger is strict compliance with the permissible values for pressure and temperature mentioned on the name plate. Exceeding these values, even as short-lasting pressure peaks will cause damage to the unit and be the cause of problems.**

To avoid costly repairs, we advise you to have the installation work and maintenance carried out by properly trained personnel.  
You can also contact relevant SONDEX Sales Office.

<b>Problem</b>	<b>Possible cause</b>	<b>Possible solution</b>
<i>Leakage</i>	At the connections	<ul style="list-style-type: none"> <li>- Check the rubber liners (if fitted)</li> <li>- Check the flange packing (if fitted)</li> <li>- Check the O-ring on the first plate</li> <li>- Fit the pipes tension-free</li> </ul>
	Mixing of primary and secondary circuit	<ul style="list-style-type: none"> <li>- Check the plates for holes and/or cracks</li> </ul>
	In plate package	<ul style="list-style-type: none"> <li>- Check the assembly distance</li> <li>- Check the condition of the packings</li> <li>- Check the proper position of the packings</li> </ul>
	The operating conditions deviate from the specification	<ul style="list-style-type: none"> <li>- Adjust the operating conditions</li> </ul>
<i>Insufficient capacity</i>	Air in the system	<ul style="list-style-type: none"> <li>- De-aerate the pipe system</li> <li>- Check the pipe work for possible air traps</li> </ul>
	The operating conditions deviate from the specification	<ul style="list-style-type: none"> <li>- Adjust the operating conditions</li> </ul>
	The heat exchanger is dirty	<ul style="list-style-type: none"> <li>- Clean the heat exchanger</li> </ul>
	The connections have been interchanged	<ul style="list-style-type: none"> <li>- Redo the fitting work</li> </ul>
<i>Too high pressure drop</i>	Flow larger than the design flow	<ul style="list-style-type: none"> <li>- Adjust the flow</li> </ul>
	Channels in plate(s) blocked	<ul style="list-style-type: none"> <li>- Flush / clean</li> </ul>
	Incorrect measurement	<ul style="list-style-type: none"> <li>- Check the pressure indicator</li> </ul>
	Medium deviating from the design	<ul style="list-style-type: none"> <li>- Addition of for instance anti-freeze will increase the pressure drop</li> </ul>
	Air in the system	<ul style="list-style-type: none"> <li>- De-aerate the pipe system</li> <li>- Check the pipe work for possible air traps</li> </ul>

For nearly all leakage problems it will be necessary to dismantle the unit before any attempts to rectify the fault can be made. Mark the area(s) where the leakage seems to be with a felt tip marker or similar before taking apart the exchanger.

“**Cold leakage**” is caused by a sudden change in temperature. The sealing properties of certain elastomers are temporarily reduced when the temperature changes suddenly. No action is required as the gaskets should re-seal after the temperature has stabilised.

***Gasket failures are generally a result of:***

- old age
- excessive exposure to ozone
- high operating temperature – above the temp. limit of the material
- exposure to pressure surges
- chemical attack
- physical damage, resulting from poor assembly practise, or damage resulting from a misaligned plate (check the hanging system at the top of the plate for distortion).

***Decrease in performance is generally a result of:***

- plate surfaces require cleaning or de-scaling
- pumps or associated controls have failed
- plate channels blocked
- liquid flows not as per design specification
- associated chiller / cooling tower / boiler under sized
- cooling water temperature to the exchanger is higher than the design
- heating media temperature to the exchanger is lower than the design
- steam flow not sufficient – control valve malfunction
- steam trap broken or jammed – unit becomes filled with condensate
- plate package has been assembled incorrectly
- unit is running in co-current flow, instead of counter current – check with contract drawing and alter pipe work if necessary. Check direction of pump flows.
- air lock has developed in the plate package or pipe work

## 10 AFTER SALES SERVICE

### 10.1 Ordering parts

When ordering parts it is important that the correct details are given. At least the following should be quoted:

- Project and order number
- Exchanger type and manufacturing number (see name plate)
- Required parts

When ordering separate plates it is important that the correct plate code index and type of plate is given. See chapter 5.2

When ordering separate gaskets it is important to indicate the correct gasket material.

When ordering tie-bolts, the existing ones should be measured in order to get new ones of the same size

### 10.2 Modifications to the heat exchanger

The plate heat exchanger is built up in modules and therefore flexible with respect to enlargements or reductions. It is easy to change the capacity by respectively enlarging or reducing the number of plates.

We would be pleased to advise you.

### 10.3 Contacts

#### **Australia**

SONDEX, Australia PTY LTD  
Phone +61 3 9728 6564  
Fax +61 3 9728 6579  
E-mail : [info@sondexaustralia.com.au](mailto:info@sondexaustralia.com.au)  
Internet: [www.sondexaustralia.com](http://www.sondexaustralia.com)

#### **Germany**

SONDEX, Deutschland GmbH  
Phone +49 4171 788330  
Fax +49 4171 788350  
E-mail: [info@sondex.de](mailto:info@sondex.de)  
Internet: [www.sondex.de](http://www.sondex.de)

#### **Holland**

SONDEX, BV  
Phone +31 299 674 934  
Fax +31 299 674 936  
E-mail: [info@sondex.nl](mailto:info@sondex.nl)  
Internet: [www.sondex.nl](http://www.sondex.nl)

#### **Italy**

SONDEX, Italy S.r.l.  
Phone +39 0363 905086  
Fax +39 0363 905422  
E-mail : [info@sondex.it](mailto:info@sondex.it)  
Internet : [www.sondex.it](http://www.sondex.it)

#### **Poland**

SONDEX, Poland  
Phone +48 58 676 0012  
Fax +48 58 676 0497  
E-mail : [ksw@sondex.pl](mailto:ksw@sondex.pl)  
Internet : [www.sondex.pl](http://www.sondex.pl)

#### **USA**

SONDEX, Inc USA  
Phone : 502 933 9991  
Fax : 502 933 9914  
E-mail : [sales@sondex-usa.com](mailto:sales@sondex-usa.com)  
Internet : [www.sondex.dk](http://www.sondex.dk)



#### **Denmark – Corporate Head Office**

SONDEX A/S  
Jernet 9 · DK-6000 Kolding.  
Tel. +45 76 30 61 00  
Fax. +45 75 53 89 68 / +45 75 50 50 19  
E-mail: [info@sondex.dk](mailto:info@sondex.dk)  
Internet: [www.sondex.dk](http://www.sondex.dk)