

# FALCON FS370

## Reach diagram — Optimized position

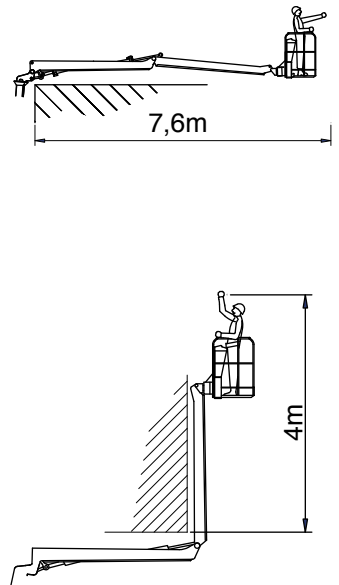
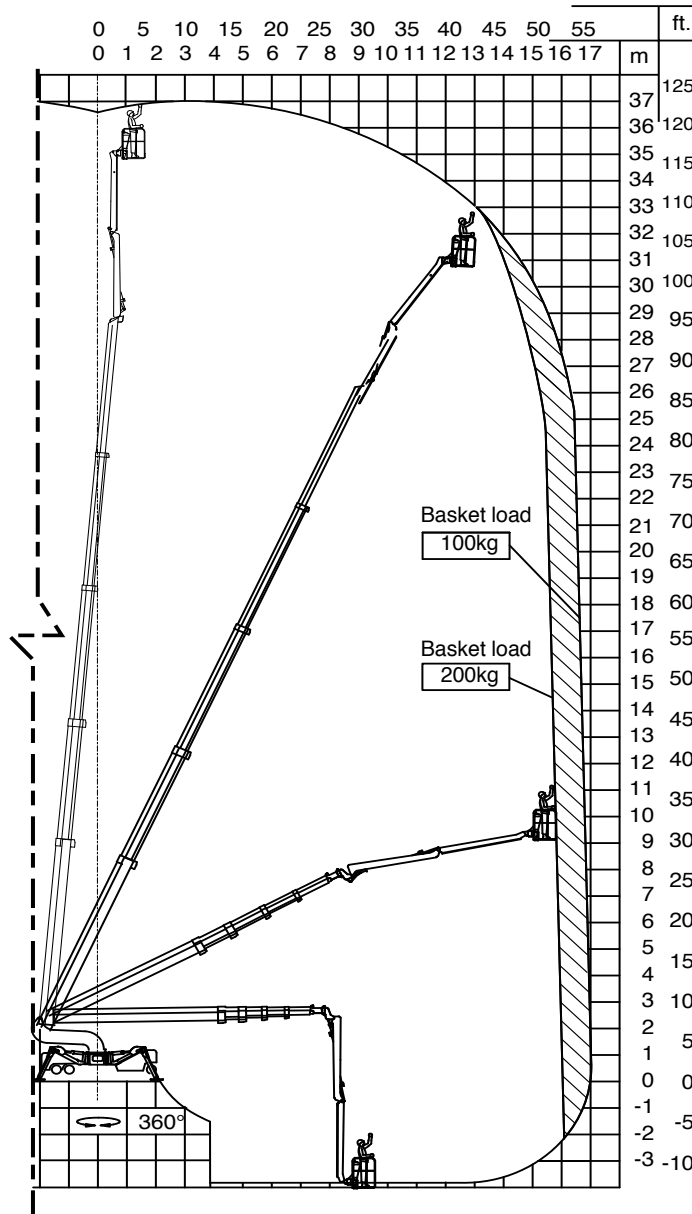
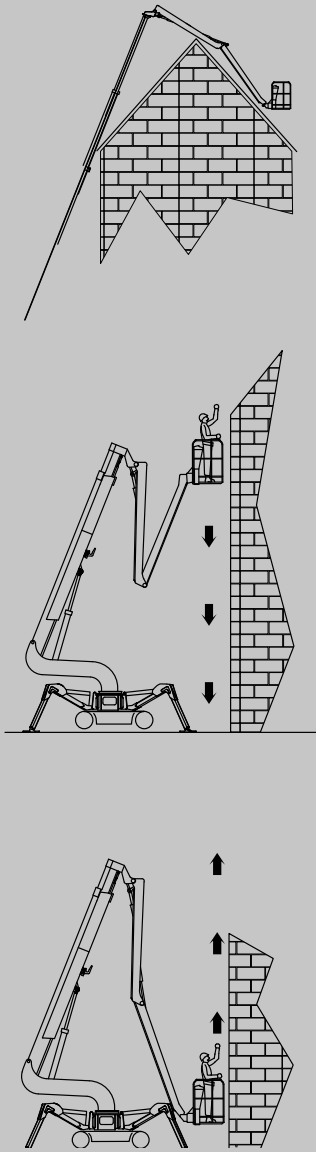

## Reach with outriggers in different positions

**Standard**

Measurements in meters

**Optimized**

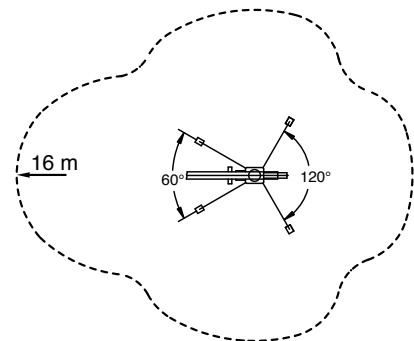
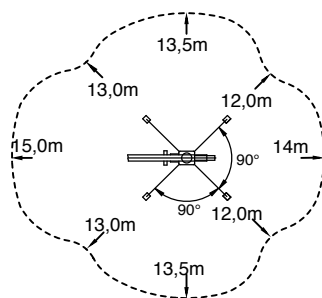

Basket load=200kg

Basket load=100kg

**TCA LIFT A/S**

Tolderlundsvej 106  
DK • 5000 Odense C  
Tel.: +45 66 13 11 00

[www.tcalift.com](http://www.tcalift.com)

All measurements are intended as guide. Choice of equipment may change the mentioned measurements

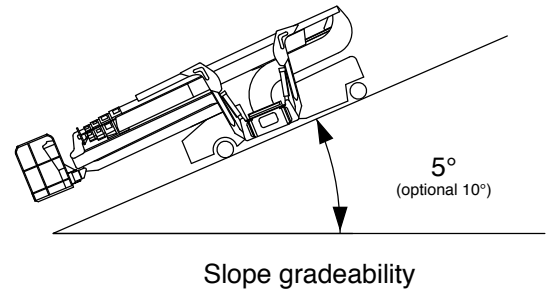
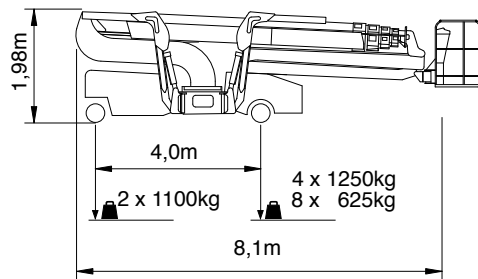
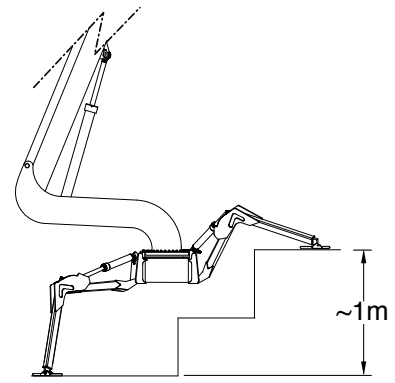
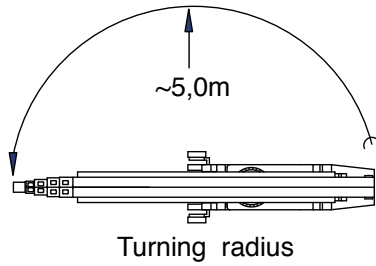
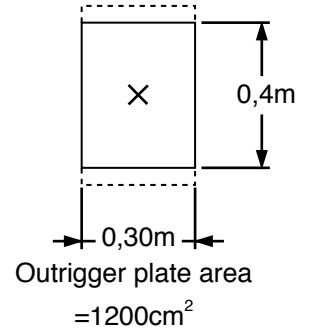
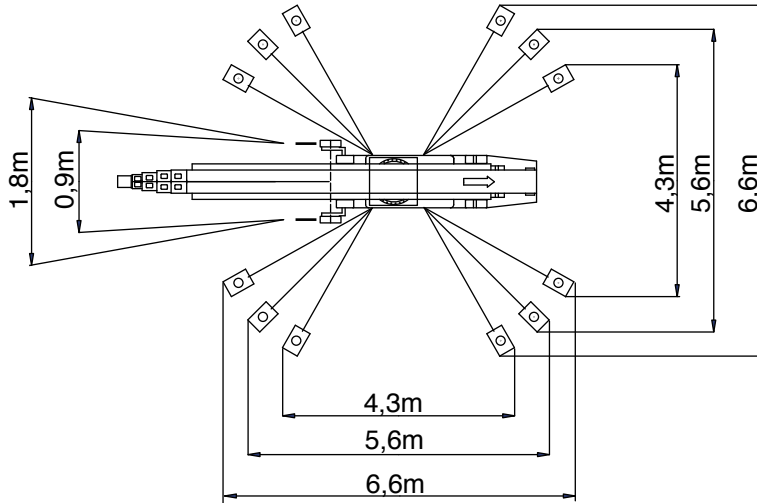
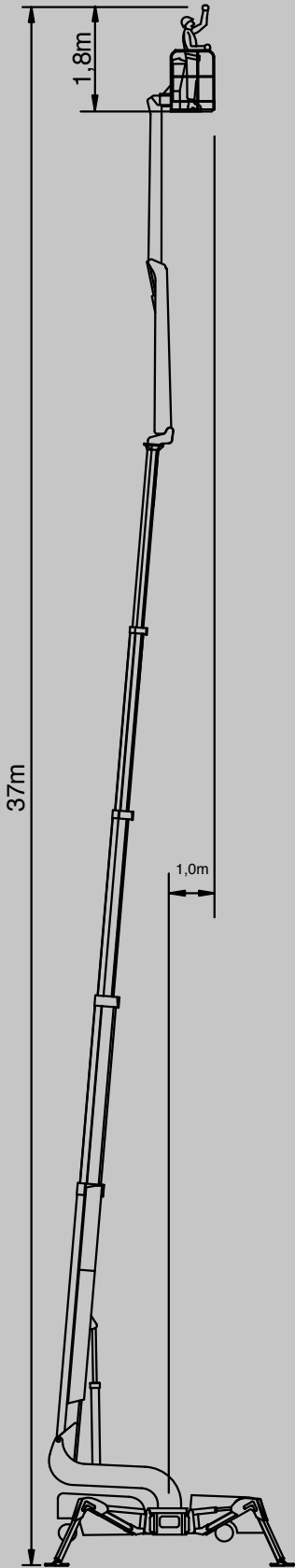

## Additional info:

### Weight and ground pressure:

Weight with standard equipment (solid tires) Bogie	7200 kg
Max. ground pressure under 1 wheel (with 4 rear wheel)	5,9 kg/cm <sup>2</sup>
Max. ground pressure under 1 wheel (with 8 rear wheel)	5,5 kg/cm <sup>2</sup>
Max. ground pressure under 1 outrigger plate	2,75 kg/cm <sup>2</sup>
Front wheel area (depending on wheel type)	2 x ~ 200 cm <sup>2</sup>
Rear wheel area (depending on wheel type)	4 x ~ 210 cm <sup>2</sup>

As all our products are in a constant process of development we reserve the right to alterations