

JTL 158.6

Topless luffing crane
Tower TH 15.2

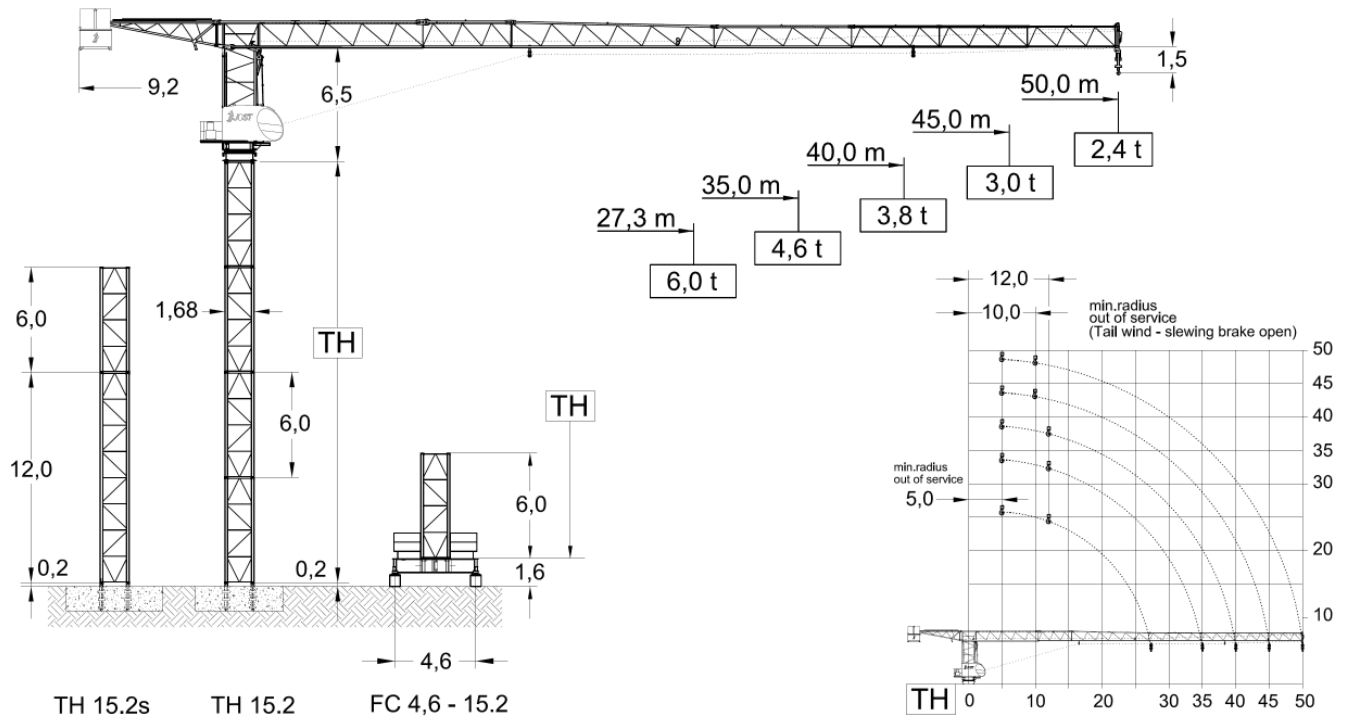

		Foundation		Chassis	
Jib length (m)		27,3 - 40,0	45,0 - 50,0	27,3 - 40,0	45,0 - 50,0
TH	TH 15.2	42,0 m	36,0 m	24,0 m	18,0 m
	TH 15.2s	48,0 m	42,0 m	--	--

Radius & Capacity											
Jib		max Load									
m	rope	t	m	22	25	27,3	30	35	40	45	50
50		3,0	40,9	3,00	3,00	3,00	3,00	3,00	3,00	2,70	2,40
		6,0	21,5	5,68	5,12	6,00	4,21	3,57	3,08	2,70	2,40
45		3,0	45,0	3,00	3,00	3,00	3,00	3,00	3,00	3,00	
		6,0	23,7	6,00	5,66	6,00	4,66	3,95	3,42	3,00	
40		3,0	40,0	3,00	3,00	3,00	3,00	3,00	3,00		
		6,0	26,1	6,00	6,00	6,00	5,17	4,39	3,80		
35		3,0	30,0	3,00	3,00	3,00	3,00	3,00			
		6,0	27,3	6,00	6,00	6,00	5,43	4,60			
27,3		3,0	27,3	3,00	3,00	3,00					
		6,0	27,3	6,00	6,00	6,00					

Speeds 400 V - 50 Hz / 440 V - 60 Hz							
Hoist unit 22 kW				Frequency inverter			
Pmax		3,0 - 6,0 (to)					
	Load [to]	1,2	1,3	1,5	1,8	2,5	3,0
	v [m/min]	80	78	68	60	46	40
	Load [to]	2,4	2,6	3,0	3,6	5,0	6,0
	v [m/min]	40	39	34	30	23	20
Drum capacity		340,0 m					

Hoist unit 30 kW							
Frequency inverter				Frequency inverter			
Pmax		3,0 - 6,0 (to)					
	Load [to]	1,2	1,3	1,5	1,8	2,5	3,0
	v [m/min]	116	110	98	86	66	58
	Load [to]	2,4	2,6	3,0	3,6	5,0	6,0
	v [m/min]	58	55	49	43	33	29
Drum capacity		340,0 m					

* Further hoist models available on request.



FEM A3
DIN 15018 H1-B3
TÜV CERT
DIN EN ISO 9001

Edition 02/07. Subject to modification.
Specifications and data not binding.

Motor	15,0 kW FI	1 x 4,4 kW	2 x 5,0 kW
t / v	2,50 min	0,77 rpm	25,0 m / min
Power requirement	Upper part	Hoist 22 kW	51 kVA
		Hoist 30 kW	60 kVA

JOST Cranes GmbH & Co. KG FON +49 (89) 456650-70
Wernher-von-Braun-Str. 10 FAX +49 (89) 456650-71
85640 Putzbrunn MAIL info@jostcranes.de
GERMANY WEB www.jostcranes.de



MTI - LUX S.A. FON +352 26745480
2a, rue Prince Henri FAX +352 26745483
L-6735 Grevenmacher MAIL mtlux@aol.com
Luxembourg WEB www.mti-lux.com