

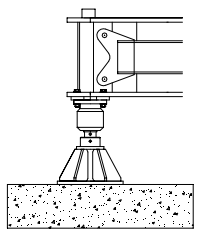

TLS 60

4-8T

2150Kg

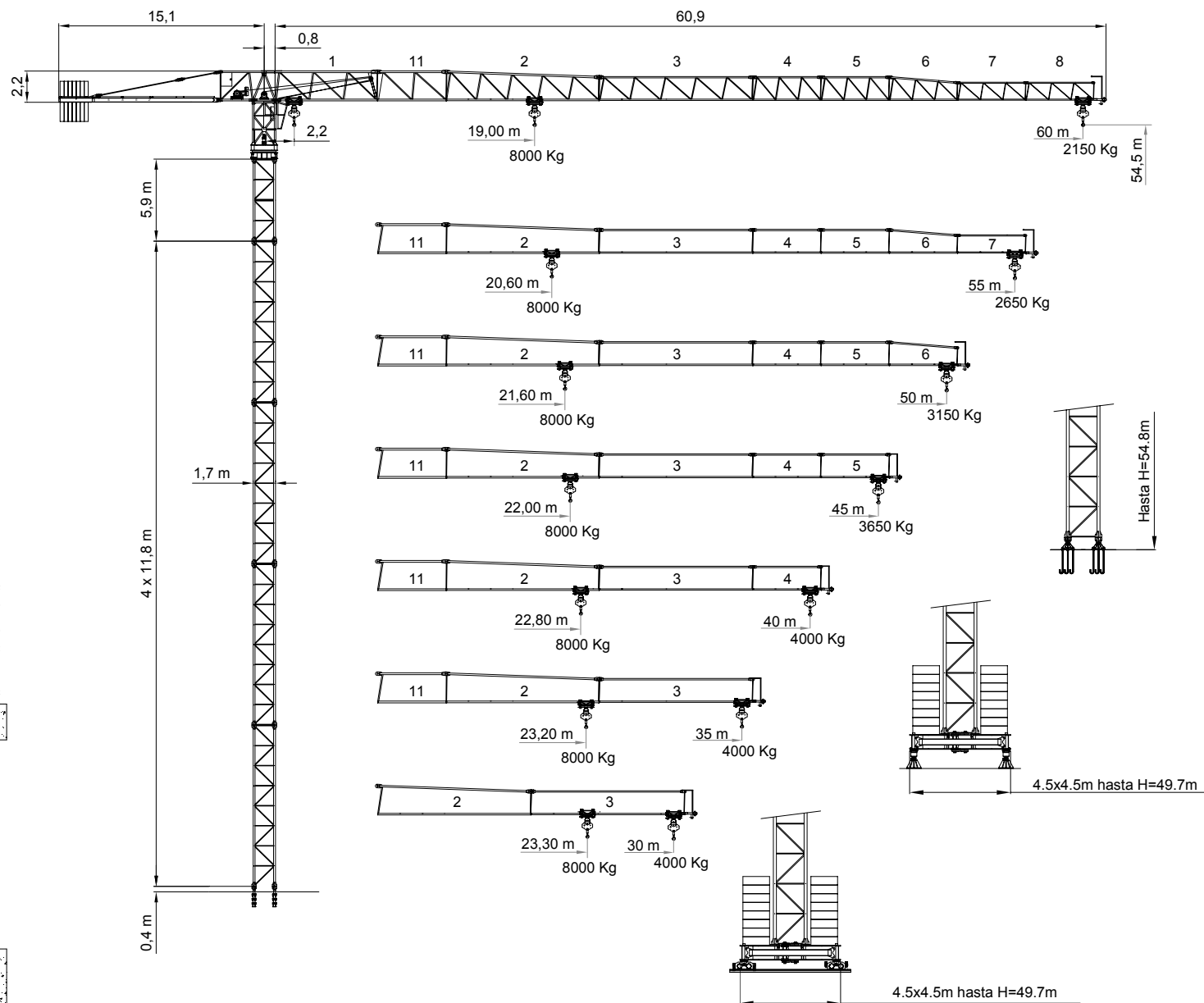

A

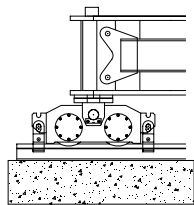

B

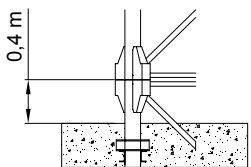

C

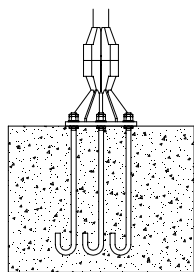

D

DIN/FEM CE

UNE 58-101-92 FEM 1001-87 Gr. A3 DIN 15018 Gr. B3
According to EC 98/37 instruction

Curvas de cargas
Load diagrams
Lastkurven
Courbes de charges
Curve di carico

60 m 	10	15	20	25	30	35	38,8	40	45	50	55	60	m	
	4000	4000	4000	4000	4000	4000	4000	3510	3050	2690	2400	2150	Kg	
55 m 	10	15	19,0	20	25	30	35	40	45	50	55	60	m	
	8000	8000	8000	7540	5850	4730	3940	3360	2900	2540	2250	2000	Kg	
50 m 	10	15	20	20,6	25	30	35	40	45	50	55	m		
	4000	4000	4000	4000	4000	4000	4000	3860	3360	2970	2650	Kg		
50 m 	10	15	20	20,6	25	30	35	40	45	50	55	m		
	8000	8000	8000	8000	6420	5210	4350	3710	3210	2820	2500	Kg		
45 m 	10	15	20	25	30	35	40,73	40	45	50	m			
	4000	4000	4000	4000	4000	4000	4000	4080	3560	3150	Kg			
45 m 	10	15	20	21,6	25	30	35	40	45	50	m			
	8000	8000	8000	8000	6780	5510	4610	3930	3410	3000	Kg			
40 m 	10	15	20	25	30	35	40	45	m					
	4000	4000	4000	4000	4000	4000	4000	3650	Kg					
40 m 	10	15	20	22	25	30	35	40	45	m				
	8000	8000	8000	8000	6940	5640	4720	4030	3500	Kg				
35 m 	10	15	20	25	30	35	m							
	4000	4000	4000	4000	4000	4000	Kg							
35 m 	10	15	20	23,2	25	30	35	m						
	8000	8000	8000	8000	7340	5970	5000	Kg						
30 m 	10	15	20	25	30	m								
	4000	4000	4000	4000	4000	Kg								
30 m 	10	15	20	23,3	25	30	m							
	8000	8000	8000	8000	7380	6000	Kg							

Mástil / Reacciones
Masts / Reactions
Maste / Eckdrücke
Mat / Réactions
Torre / Reazioni

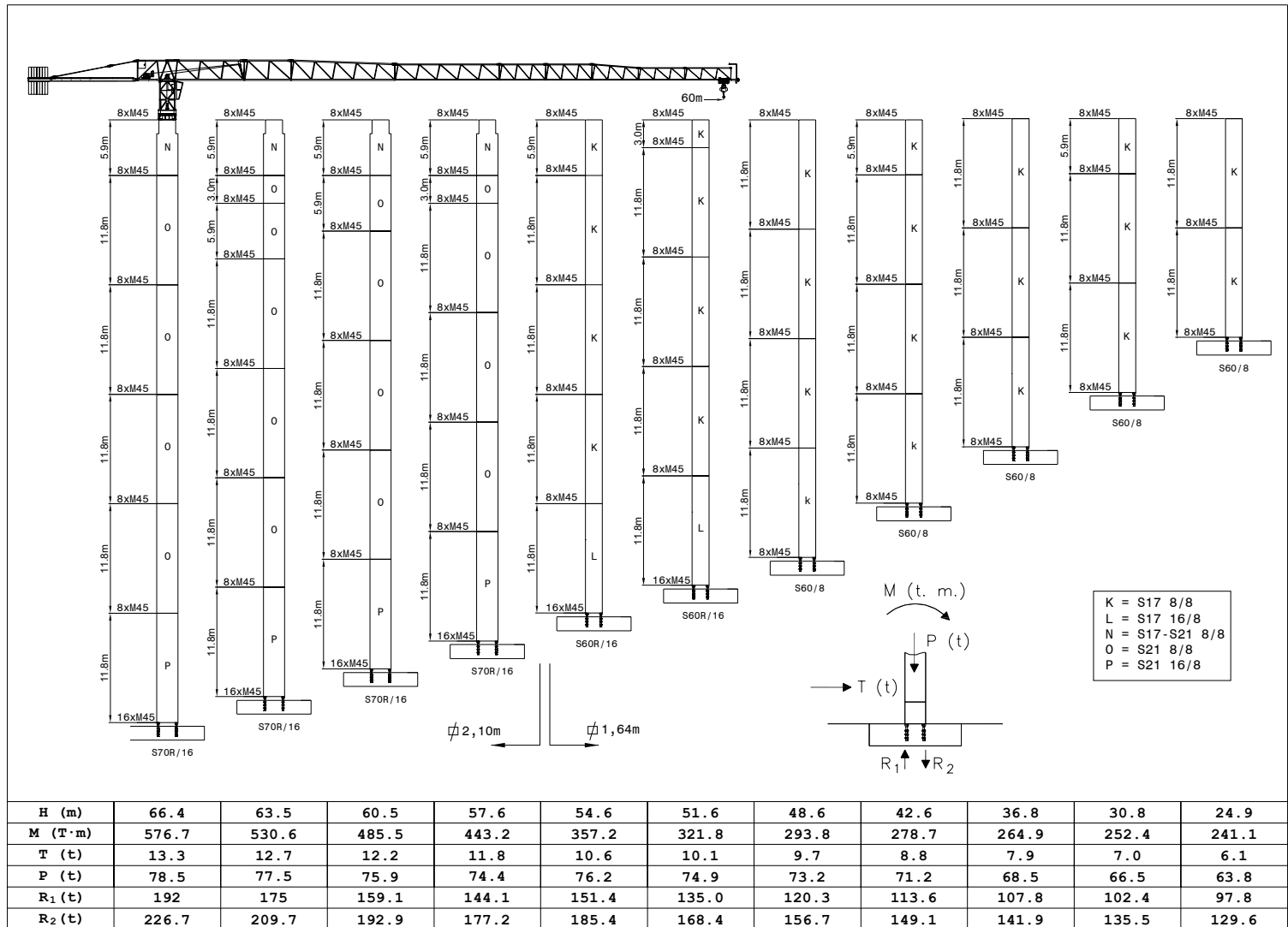

**Mecanismos
Mechanisms
Antriebe
Mécanismes
Meccanismi**

	m/min	11	45	90	4,5	22,5	45
	Kg	4000	4000	2000	8000	8000	4000
	Kw	33	33	33	33	33	33
	m/min	30 / 60			30 / 60		
	Kw	3,0			3,0		
	r.p.m	0,3	0,6	0,9	0,3	0,6	0,9
	Nm	2 x 65			2 x 65		
	m/min	12 / 24			12 / 24		
	Kw	4 x 3			4 x 3		

* 45 Hp (33Kw) - CC.

	m/min	40	60	80	120	20	30	40	60
	Kg	4000	3000	2000	1250	8000	6000	4000	2500
	Kw	33	33	33	33	33	33	33	33

* Opcional / Optional / Opzionale /

Elevación / Hoisting / Heben / Levage / Sollevamento

Distribución / Trolleying / Katzfahren / Distribution / Ditrribuzione

Orientación / Slewing / Schwenken / Orientation / Rotazione

Traslacion / Travelling / Schienenfahren / Translation / Traslazione

	380 V 50 Hz	55 kVA
--	----------------	--------



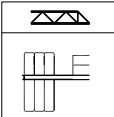

Bloque de contrapeso
Counterweight blocks
Gegengewichtsblöcke
Bloc de contrepoid
Blocco di contrappeso

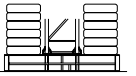
	60 m			55 m			50 m			45 m			40 m			35 m			30 m		
	A	B	C	A	B	C	A	B	C	A	B	C	A	B	C	A	B	C	A	B	C
	8	-	-	7	1	-	6	2	-	6	1	-	6	-	-	4	2	-	3	2	-
	20000 Kg			19000 Kg			18000 Kg			16500 Kg			15000 Kg			13000 Kg			10500 Kg		

Bloque lastre de base
Base ballast block
Grundballastblöcke
Bloc de lest de base
Blocco di zavorra alla base

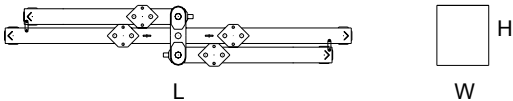
	14,30 m	20,20 m	26,10 m	32,0 m	37,90 m	45,8 m	49,70 m
4,5 x 4,5 m	53,2 t	60,8 t	76 t	83,6 t	98,8 t	121,6 t	121,6 t

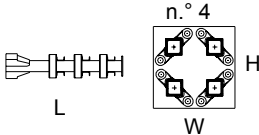
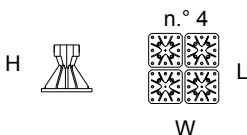
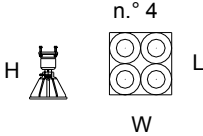
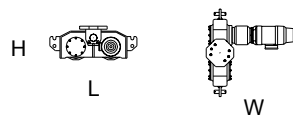
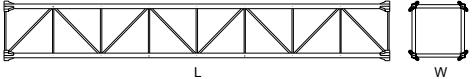
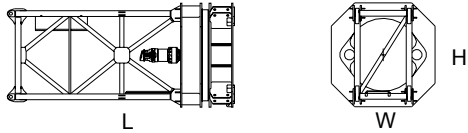
		L (m)	W (m)	H (m)	Peso (Kg)	
<p>Pluma tramo primero Jib heel section Ausleger-Anlenkstück Pied de flèche Settore articolato di braccio</p>		11,90	1,25	2,30	5800	
<p>Elemento intermedio de pluma Intermediate jib section Ausleger-Zwischenstück Elément interm. de flèche Spezzone di braccio</p>		2 3 4 5 6 7 8 11	11,60 11,60 5,30 5,30 5,30 5,30 5,30 5,30 5,15	1,13 1,13 1,13 1,13 1,13 1,13 1,13 1,13 1,13	2,25 1,80 1,80 1,80 1,80 1,45 1,45 2,25	2145 1676 596 516 444 410 320 1275
<p>Gancho, Carro y Puntera Hook, Trolley and jib head Lasthaken - Laufkatze-Cabeça de Lança Crochet - Chariot-Pointe de flèche Gancio - Carrello e Punta freccia</p>		1,20 0,80 0,80	1,35 0,15 1,20	0,80 1,50 1,40	276 316 75	
<p>Contrapluma Counter-jib Gegenausleger Contre-flèche Controbraccio</p>		11,94	1,80	0,60	2840	
<p>Bloque de contrapeso Counterweight blocks Gegengewichtsblöcke Bloc de contrepoids Blocco di contrappeso</p>		3,20 1,83	1,25 1,25	0,29 0,29	2500 1500	

		L (m)	W (m)	H (m)	Peso (Kg)	
Base Cruciforme 4,5 X4,5 Crossbase 4,5 X 4,5 Fundamentkreuz 4,5 X 4,5 Châsis 4,5 X 4,5 Carro base 4.5 X 4.5 Vigas auxil. de base Half base beams Halbträger für fundamentkreuz Semipoutre de châsis de base Travi di congiunzi di congiunzione		6,70	1,10	1,20	5900	
		4,40	0,30	0,55	450	
Bloque lastre de base Base ballast block Grundballastblöcke Bloc de lest de base Blocco di zavorra alla base		4,40	0,30	1,20	3800	
Elemento de empotre Elementos atornillados Foundation anchor Tied sections Fundamentanker Pyramide M. schrauben Élément de scellement Éléments vissés El annegare El recuperabile		1,50	0,70	0,70	750	
		1,35	1,35	0,60	1150	
Niveladores Traslacion Levellers Travelling bogies Spindel pyramide Kranfahren Niveleurs Traslacion Piedi regolabile Traslazione		1,20	1,20	0,90	1150	
		1,15	1,25	0,45	800	
Elemento de torre TL16 Tower section TL16 Turmstück TL16 Elcment de mât TL16 Elemento di torre TL16		TL16	11,80	1,85	1,85	4600
		TR16	11,80	1,85	1,85	5740
		TS16	5,95	1,85	1,85	2450
		TC16	3,00	1,85	1,85	1380
Unidad de rotacion Complete slewing unit Drehbühne Orientation Rotazione		4,40	2,00	2,00	6600	
Cabina y soporte Cabin and support Kabine und wartungs Cabine et support Cabina e supporto		3,00	1,15	2,35	500	

ESPECIFICACIONES SUJETAS A MODIFICACIONES SIN PREVIO AVISO.
Specifications subject to modification without notice.
Obiges kann ohne berstaendigung geaendert werden.
Specifications susceptibles de modification sans avis préalable.
Specifiche suscettibili di variazioni senza preavviso.

DECLINAMOS TODA RESPONSABILIDAD DERIVADA DE LA INFORMACION PROPORCIONADA.
This information is supplied without liability.
Sämtliche Angaben erfolgen ohne Gewähr.
Ces renseignements sont sans garantie.
Le indicazioni contenute si intendono salvo errori ed omissioni.