

FRIZA



Schröder





# FRIZA



Design: Achilles Design



## CHARACTERISTICS – LUMINAIRE

Optical compartment tightness level:	IP 66 <sup>(*)</sup>
Control gear compartment tightness level:	IP 66 <sup>(*)</sup>
Impact resistance (polycarbonate):	IK 08 <sup>(**)</sup>
Aerodynamic resistance (CxS):	0.08m <sup>2</sup>
Nominal voltage:	230V - 50 Hz
Electrical class:	I or II <sup>(*)</sup>
Weight:	9kg

### Materials

Top cover and protector:	Polycarbonate
Base and gear plate:	High-pressure die-cast aluminium
Colour:	AKZO grey 900 sanded Any other RAL or AKZO colour upon request

(\*) according to IEC - EN 60598

(\*\*) according to IEC - EN 62262

## KEY ADVANTAGES

- Cost effective lighting solution for creation of ambience
- Right lighting through LensoFlex®2 offering high performance photometry, comfort and safety
- IP 66 tightness level for long lasting performance
- Supplied pre-wired to facilitate the installation
- Tool free access for maintenance (optional)
- FutureProof: easy replacement of the photometric engine and electronic assembly
- Surge protection 10kV
- Designed to incorporate Owlet range of control solutions

## MODERN CLASSIC DESIGN FOR COST-EFFECTIVE RESIDENTIAL LIGHTING

Adapted to various urban landscapes such as residential areas, parks, squares, bicycle paths and urban centres, the Friza luminaire combines a timeless design with the energy efficiency of the latest LED technology.

The name Friza refers to Friesland, a Dutch province and one of the many regions where the original conical 'Kegel' luminaire remains very popular.

This classical shape is now refreshed to provide an aesthetic continuity while generating massive energy savings. Thanks to the combination of LensoFlex®2 engines and structured protectors, Friza ensures photometric performance and comfort (low glare) to offer safety and well-being in the public space.

The base section and gear plate of the Friza are made of high-pressure die-cast aluminium while the protector and cover are made of polycarbonate. The design of the Friza luminaire guarantees an IP 66 tightness level to maintain performance over time.

## OPTIONS

- Warm white (3000K)
- Tool free opening
- Back light control
- Owlet control solutions

## DIMENSIONS - MOUNTING

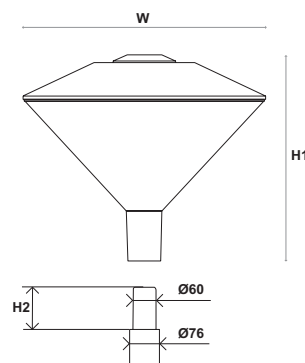

W	564mm
H1	462mm
H2	100mm

The Friza luminaire offers slip-over mounting onto a 60mm diameter spigot by the tightening of 2 M8 screws.

## BEST RETURN ON INVESTMENT FOR AMBIANCE LIGHTING

The Friza offers the best savings to investment ratio in ambiance lighting thanks to its affordable pricing and high performance. This efficiency enables a lower payback time for a new scheme and provides benefits from the savings for many years afterwards.

As energy costs will keep increasing, the best energy is energy that is not used. Investing in the Friza optimises the Total Cost of Ownership of your lighting installation.

## ENERGY SAVINGS OF UP TO 75%

The Friza luminaire integrates the latest cutting edge technologies. The combination of LEDs, a driver with a constant flux system and dimming makes it possible to achieve energy savings that can reach up to 75% compared with luminaires equipped with traditional light sources.

With this very favourable energy balance, the Friza luminaire contributes to the effective management of finances and to the responsible use of energy.

## LENSOFLEX®2

The Friza luminaire is equipped with second generation LensoFlex®2 photometric engines that have been specifically developed for lighting spaces where the well-being and safety of people using the environments are essential. This system is based upon the addition principle of photometric distribution. Each LED is associated with a specific lens that generates the complete photometric distribution of the luminaire. It is the number of LEDs in combination with the driving current that determines the intensity level of the light distribution.

## BACK LIGHT CONTROL PREVENTING INTRUSIVE LIGHT

As an option, some versions of the Friza can be equipped with a Back Light Control system.

Thanks to an additional control plate inside the luminaire body, light spill from the back of the luminaire is minimised to avoid intrusive light on buildings.

## TOOL FREE OPENING

As an option, the Friza luminaire is available in a tool free version to ease potential interventions. The Friza is FutureProof. Both the LED unit and the electronic assembly can be easily replaced to take advantage of any future technological developments.

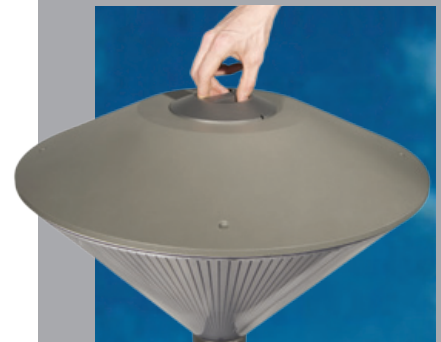

PHOTOMETRY

LENSOFLEX®2						Lifetime residual flux @ t <sub>a</sub> 25°C (**)
Number of LEDs	Neutral white (4000K)	8 LEDs	16 LEDs	32 LEDs	48 LEDs	@100.000h
Current: 350mA	Nominal flux (lm)*	-	2400	4800	7200	90%
	Power consumption (W)	-	19	37	54	
Current: 500mA	Nominal flux (lm)*	-	3100	6300	-	
	Power consumption (W)	-	26	52	-	
Current: 700mA	Nominal flux (lm)*	2000	4000	-	-	80%
	Power consumption (W)	19	38	-	-	

(\*) The nominal flux is an indicative LED flux @ t<sub>a</sub> 25°C based on LED manufacturer's data. The real flux output of the luminaire depends on environmental conditions (e.g. temperature and pollution) and the optical efficiency of luminaire.

Nominal flux depends on the type of LED in use and likely to change in accordance with the continuous and rapid developments in LED technology. To follow the progress of the luminous efficiency of the LEDs used, please visit our website.

(\*\*) In accordance with IES LM-80 - TM-21.

LIGHT DISTRIBUTIONS



**Optics 5102-5103 - street:**  
Designed for lighting narrow streets, footpaths, cycle paths...



**Optic 5068 - urban road:**  
Perfectly suited to lighting both roads and pavements in residential areas and urban streets.



**Optic 5068 - square:**  
Designed to light squares, parks, car parks, etc.



**Optic 5119 - large space:**  
Extensive light distribution for large areas to free urban spaces.

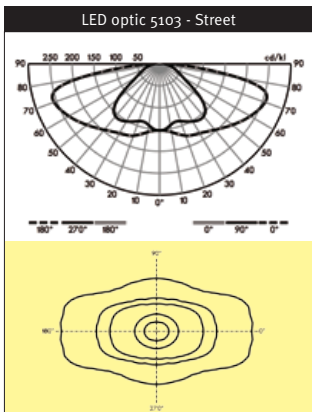
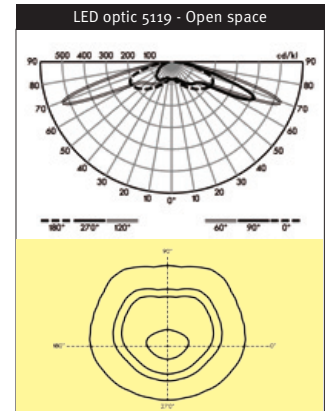
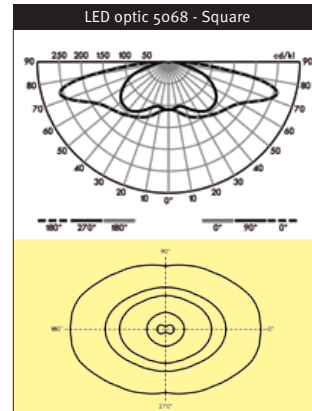
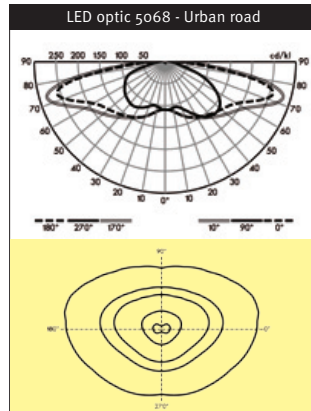
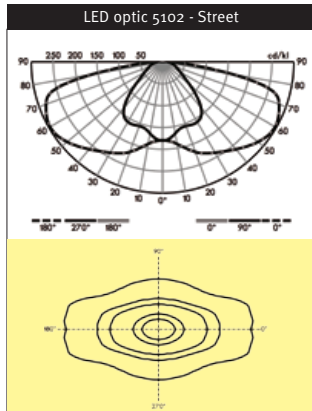

## SMART LIGHTING

The Friza luminaire can integrate the Owlet range of control solutions to operate either in stand-alone mode, in an autonomous network or an interoperable network. Our range of solutions encompasses small areas to complete city networks in order to perfectly suit your requests and your targets in terms of savings.



Thanks to dimming features, light-on-demand options and bi-directional communication, the Owlet solutions allow you to save energy, to provide light only when and where it is required and to optimise the operational management of your lighting scheme in terms of costs and services. The integrated Owlet solutions are key to monitor, to control, to meter and to manage a lighting network in the most efficient way.

### PHOTOCELL (STAND-ALONE)

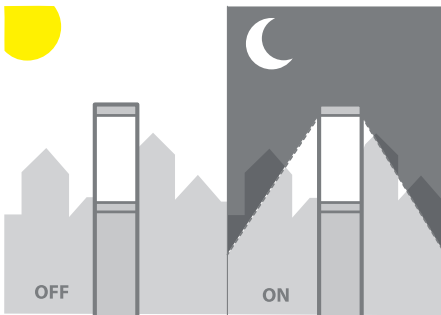

### MOTION DETECTION (AUTONOMOUS NETWORK)

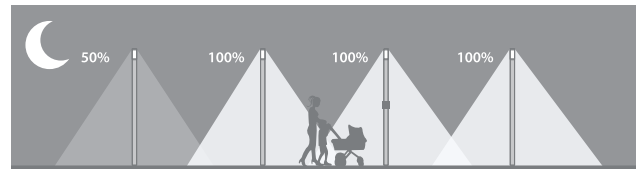
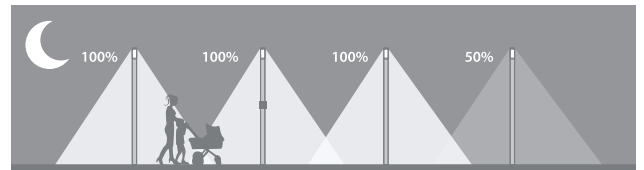
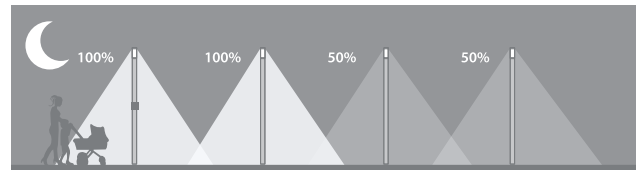
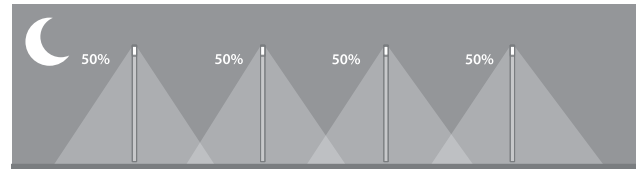

### REMOTE MANAGEMENT SYSTEM (INTEROPERABLE NETWORK)

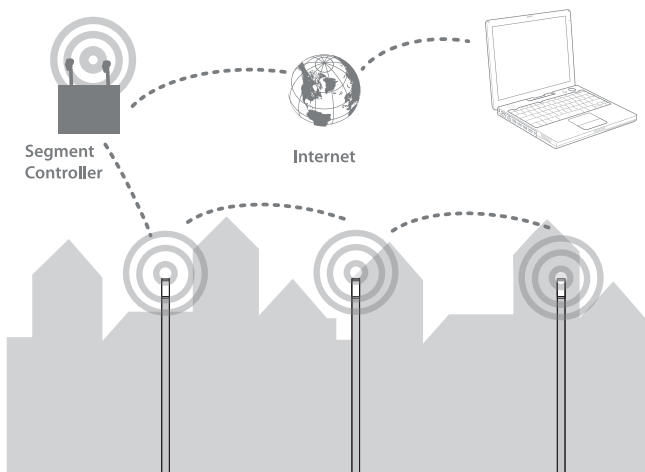



## A COMPLETE SOLUTION

The Friza luminaire can be aesthetically associated with the Lignum street furniture range including benches with or without a back, litterbins and bollards.

The Lignum line offers many interesting features:

- Pure design and robustness to blend into the environment
- Eye-catching short but comfortable backrest
- Long versions (3700mm) available for popular areas
- Quality finish: zinc-plated metal parts with a polyester powder coating
- Warm coloured FSC wood using a natural shade liquid emulsion wood stain
- Compact, robust and ergonomic 70 litre litterbin with integrated ashtray (option)
- Sturdy bollards made of steel and aluminium, available in two sizes (800 and 1200mm)



## QUALITY COLUMNS

Schröder's offer includes a wide range of columns to provide quality ensembles offering aesthetical consistency. Our columns are available in different designs and different heights to fit your project.

More information upon request.

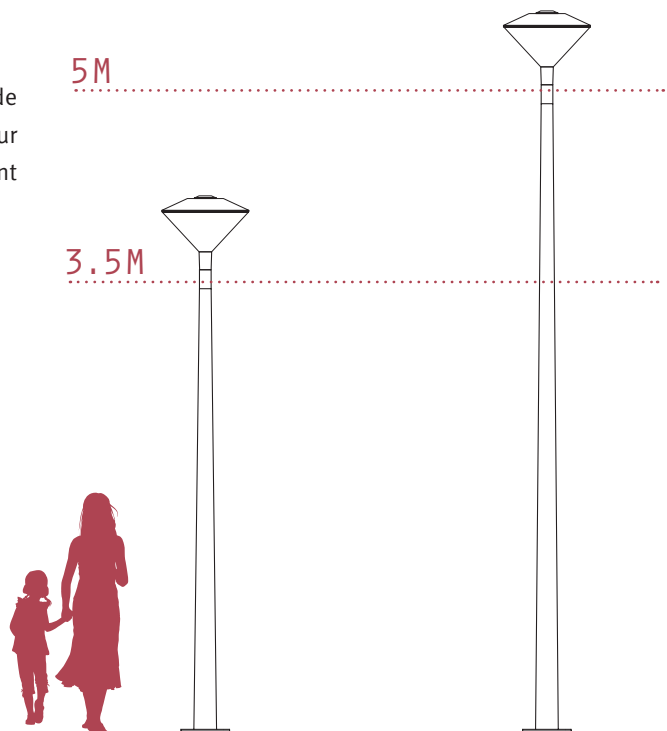



## CASE STUDY



Friza  
LensoFlex®2 16 LEDs @350mA  
4000K neutral white  
19W  
MF = 0.85  
S5 - classified street according to CIE 115  
Installation height: 4.3m  
Spacing between columns: 27m

By replacing the old luminaires, equipped with 36W fluorescent tubes, with Friza 16 LED fixtures **the energy consumption has been reduced by 48%.**

For 4,000 hours of use per year, for 1km of residential street, this corresponds to a consumption of less than 7.6kWh/day and emissions lower than 3.5kg eq CO<sub>2</sub> according to the average European equivalent of 0.46kg eq CO<sub>2</sub>/kWh.

Further energy savings can be achieved by adding dimming and other control features to the luminaires.





Copyright © Schröder S.A. 2014. - Executive Publisher: Marie-Gabrielle Kokken - L.a.W. S.A. - rue de Mons 3 - B-4000 Liège (Belgium) - The information, descriptions and illustrations herein are of only an indicative nature. Due to advanced developments, we may be required to alter the characteristics of our products without notice. As these may present different characteristics according to the requirements of individual countries, we invite you to consult us.

