



Sectional Garage Doors

Technical Manual: Issue 01.03.2012



Contents

Contents	Page
Door type / door leaf	3–4
Door type / door leaf	4
LTE 40, S-ribbed, Woodgrain	5
LTE 40, M-ribbed, Woodgrain	6
LTE 40, S-panelled, Woodgrain	7
EPU 40, M-ribbed, Woodgrain	8
EPU 40, S-panelled, Woodgrain	9
LPU 40, S-ribbed, Woodgrain	10
LPU 40, M-ribbed, Woodgrain	11
LPU 40, M-ribbed, Silkgrain	12
LPU 40, M-ribbed, Micrograin	13
LPU 40, M-ribbed, Decograin	14
LPU 40, L-ribbed, Woodgrain	15
LPU 40, L-ribbed, Silkgrain	16
LPU 40, L-ribbed, Micrograin	17
LPU 40, L-ribbed, Decograin	18
LPU 40, S-panelled, Woodgrain	19
LPU 40, S-panelled, Decograin	20
Sunrise glazing LTE 40 / EPU 40 / LPU 40	21
Design element LPU 40	22
LPU 40 with wicket door, S, M, L-ribbed, Woodgrain, Micrograin or Decograin	23
LPU 40 with wicket door, S, M, L-ribbed, matching exterior view for doors with glazing	24
LPU 40 with wicket door, S-panelled, Woodgrain	25
LPU 40 with wicket door, arrangement of the wicket door	26
LTH 40, S-, M-, L-ribbed, V-panelled	27
LTH 40 with special designs	28
LPU 40, S-ribbed, Woodgrain, fitting in front of the reveal	29
LPU 40, M-ribbed, Woodgrain, fitting in front of the reveal	30
LPU 40, M-ribbed, Silkgrain, fitting in front of the reveal	31
LPU 40, M-ribbed, Micrograin, fitting in front of the reveal	32
LPU 40, L-ribbed, Woodgrain, fitting in front of the reveal	33
LPU 40, L-ribbed, Silkgrain, fitting in front of the reveal	34
LPU 40, L-ribbed, Micrograin, fitting in front of the reveal	35
Track applications Z and N	36
Track applications L and H	37
Track application N with wicket door	38
Track application L with wicket door	39
Track applications BZ and BL	40
Track application BL with wicket door	41
Track application Z, fitting in front of the reveal	42
Sideroom	43
Sideroom and lintel fitting with ThermoFrame	44
Sideroom, fitting in front of the reveal	45
Lintel fitting with fascia panels	46
Bottom edge	47
Side doors with corner frames made of aluminium profiles, standard sizes	48–49
Side doors with block frames made of aluminium profiles, standard sizes	50–51
Side doors with block frames made of aluminium profiles, special sizes	52–53
Timber side doors, standard sizes / special sizes	54
Garage door operators ProMatic, SupraMatic E, P, H and HD	55–57

Door leaf constructions and track applications as well as fitting examples are provided in this manual.

Before fitting a sectional door, the structural opening must be finished and the garage floor must be laid and level.

No part may be reproduced without our prior permission.

All rights reserved.

All dimensions in mm

Subject to design changes.

Door type	Door leaf
Sectional door LTE 40 – Single-skinned steel sections	
<ul style="list-style-type: none"> • S-ribbed Woodgrain • M-ribbed, Woodgrain 	<ul style="list-style-type: none"> • Single-skinned door sections, Woodgrain-embossed • Equal-height door sections, horizontally ribbed, in hot-galvanized sheet steel • Surface with polyester-primer coating • Glazings not possible in the two bottom door sections
<ul style="list-style-type: none"> • S-panelled Woodgrain 	<ul style="list-style-type: none"> • Single-skinned door sections, Woodgrain-embossed • Hot galvanized sheet steel door sections of equal height with panelling • Surface with polyester-primer coating • Glazings not possible in the two bottom door sections
Sectional door EPU 40 – Double-skinned steel sections	
<ul style="list-style-type: none"> • M-ribbed, Woodgrain 	<ul style="list-style-type: none"> • Double-skinned, PU-foamed door sections, 42/20 mm, Woodgrain-embossed exterior, Stucco-textured interior • Equal-height door sections, horizontally ribbed, in hot-galvanized sheet steel • Surface with polyester-primer coating • Glazings not possible in the two bottom door sections
<ul style="list-style-type: none"> • S-panelled Woodgrain 	<ul style="list-style-type: none"> • Double-skinned, PU-foamed door sections, 42/20 mm, Woodgrain-embossed exterior, Stucco-textured interior • Hot galvanized sheet steel door sections of equal height with panelling • Surface with polyester-primer coating • Glazings not possible in the two bottom door sections
Sectional door LPU 40 – Double-skinned steel sections	
<ul style="list-style-type: none"> • S-ribbed Woodgrain • S-ribbed, Woodgrain, Silkgrain, Micrograin or Decograin • L-ribbed, Woodgrain, Silkgrain, Micrograin or Decograin 	<ul style="list-style-type: none"> • Double-skinned, PU-foamed door sections, Woodgrain, Silkgrain, Micrograin, or Decograin exterior, Stucco-textured interior • Hot galvanized sheet steel door sections of equal height with horizontal ribbing or without ribbing • Surface with polyester-primer coating (with Decograin, plastic film coating on the outside) • Glazings not possible in the two bottom door sections
<ul style="list-style-type: none"> • S-panelled, Decograin 	<ul style="list-style-type: none"> • Double-skinned, PU-foamed door sections, Woodgrain or Decograin-embossed exterior, Stucco-textured interior • Hot galvanized sheet steel door sections of equal height with panelling • Surface with polyester-primer coating (with Decograin, plastic film coating on the outside) • Glazings not possible in the two bottom door sections
Fitting in front of the reveal <ul style="list-style-type: none"> • S-ribbed Woodgrain • M-ribbed, Woodgrain or Silkgrain • L-ribbed, Woodgrain, Silkgrain or Micrograin 	<ul style="list-style-type: none"> • Double-skinned, PU-foamed door sections, Woodgrain, Silkgrain, or Micrograin exterior, Stucco-textured interior • Hot galvanized sheet steel door sections of equal height with horizontal ribbing or without ribbing • Surface with polyester-primer coating • Glazings not possible in the two bottom door sections
Fitting in front of the reveal <ul style="list-style-type: none"> • S-panelled Woodgrain 	<ul style="list-style-type: none"> • Double-skinned, PU-foamed door sections, Woodgrain-embossed exterior, Stucco-textured interior • Hot galvanized sheet steel door sections of equal height with panelling • Surface with polyester-primer coating • Glazings not possible in the two bottom door sections
Sectional door LPU 40 with wicket door – Double-skinned steel sections	
<ul style="list-style-type: none"> • S-ribbed Woodgrain • M-ribbed, Woodgrain, Micrograin or Decograin • L-ribbed, Woodgrain, Micrograin or Decograin 	<ul style="list-style-type: none"> • Double-skinned, PU-foamed door sections, Woodgrain, Micrograin or Decograin exterior, Stucco-textured interior • Hot galvanized sheet steel door sections of equal height with horizontal ribbing or without ribbing • Surface with polyester-primer coating (with Decograin, plastic film coating on the outside) • Glazings not possible in the two bottom door sections • Without door handle set, without inside locking, without single-skinned steel fascia, upper door section with lintel seal • We recommend fitting a garage door operator SupraMatic P.

Further details can be obtained in the brochure.

Door type	Door leaf
<ul style="list-style-type: none"> • S-panelled Woodgrain 	<ul style="list-style-type: none"> • Double-skinned, PU-foamed door sections, Woodgrain-embossed exterior, Stucco-textured interior • Hot-galvanized sheet steel door sections of equal height with panelling • Surface with polyester-primer coating • Glazings not possible in the two bottom door sections • Without door handle set, without inside locking, without single-skinned steel fascia, upper door section with lintel seal • We recommend fitting a garage door operator SupraMatic P.

Sectional door LTH 40

<ul style="list-style-type: none"> • S-ribbed, Nordic Pine / Hemlock • M-ribbed, Nordic Pine / Hemlock • L-ribbed, Nordic Pine / Hemlock • V-panelled, Nordic Pine / Hemlock 	<ul style="list-style-type: none"> • Solid timber door sections, S, M, L-ribbed or V-panelled • Door sections of equal height • Pine-impregnated surface protects against blue stain and wood pests • Glazings not possible in the two bottom door sections
--	---

Sectional door LTH 40 with special designs

Nordic Pine / Hemlock	<ul style="list-style-type: none"> • Solid timber sections with different door styles • Door sections of equal height • Pine-impregnated surface protects against blue stain and wood pests • Door styles 403 and 404 with natural stone infill on request
------------------------------	--

Further details can be obtained in the brochure.

Door type	Door leaf
-----------	-----------

Side doors with corner frames made of aluminium profiles

Standard sizes	<ul style="list-style-type: none"> • Appearance same as LTE 40 / EPU 40 / LPU 40, leaf frame made of aluminium extrusions, depth 60 mm • PU-foamed steel-section door infill; Woodgrain, Decograin or Silkgrain-embossed exterior, Stucco-textured interior. • Surface with polyester-primer coating (with Decograin, plastic film coating on the outside) • Alignment of sections / ribbing / panelling is only possible with doors of the same height
-----------------------	---

Side doors with block frames made of aluminium profiles

Standard / special sizes	<ul style="list-style-type: none"> • Appearance same as LTE 40 / EPU 40 / LPU 40, leaf frame and frame made of aluminium extrusions (without thermal breaks), depth 60 mm, double buffer sealing on 3 sides • As standard, plug holes are pre-drilled in the frame according to the fitting arrangement (see reverse side of the order form) • PU-foamed steel-section door infill; Woodgrain, Decograin or Silkgrain-embossed exterior, Stucco-textured interior. • Surface with polyester-primer coating (with Decograin, plastic film coating on the outside) • Alignment of sections / ribbing / panelling is only possible with doors of the same height
---------------------------------	--

Timber side doors

Standard / special sizes	<ul style="list-style-type: none"> • Appearance same as LTH 40 • Solid timber door leaf and frame, Nordic Pine or Hemlock; door leaf depth 42 mm, buffer sealing on 3 sides • Double seal in threshold area • Pine-impregnated surface protects against blue stain and wood pests
---------------------------------	---

Further details can be obtained in the brochures.

Sectional Door LTE 40

Single-skinned steel sections

S-ribbed

Woodgrain

External views

(The illustrations correspond to size 2500 × 2125 mm. Deviations may occur with other door sizes.)

Basic model



With aluminium frame

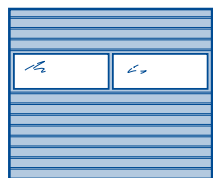

With glazing type D

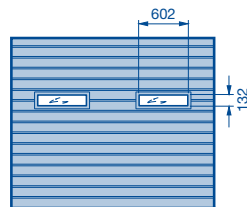

Note:

Different glazing arrangements are not possible!

Size range

Door width in 5 mm increments, door height in grid height. Intermediate heights are not possible.

		A	B	C										
RM	3000	6	500	125										
	2875	6	479	120										
	2750	5	550	138										
	2625	5	525	131										
	2500	5	500	125										
	2375	5	475	119										
	2250	4	562	141										
	2205	4	550	138										
	2125	4	531	133										
	2080	4	520	130										
	2000	4	500	125										
	1955	4	488	122										
	1875	4	468	117										
		Number of infills per door section with glazing												
		2	3	4	5									
		2250	2375	2500	2750	3000	3250	3500	3750	4000	4250	4500	4750	5000
		LZ												

Doors up to 3000 × 2625 mm, with tension spring assembly

A No. of door sections

B Door section height

C Spacing

RM Grid height

LZ Clear frame dimensions (from 2000)

Special equipment

Ventilation

- Ventilation slots in bottom door section, ventilation cross section 65 cm² for one metre door width
- Ventilation slots in bottom door section ventilation cross section 65 cm² for one metre door width
- Aluminium frame with expanded mesh 58 % ventilation cross section

Glazing options

- Aluminium frame (standard profile NF)
- Glazing type D, 3 mm

Sectional Door LTE 40

Single-skinned steel sections

M-ribbed

Woodgrain

External views

(The illustrations correspond to size 2500 × 2125 mm. Deviations may occur with other door sizes.)

Basic model

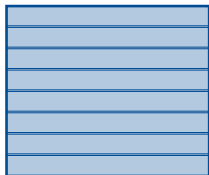

With aluminium frame



With glazing type D

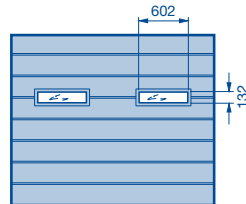

Note:

Different glazing arrangements are not possible!

Size range

Door width in 5 mm increments, door height in grid height. Intermediate heights are not possible.

													A	B	C					
RM	3000														6	500	250			
	2875														6	479	239			
	2750														5	550	275			
	2625														5	525	262			
	2500														5	500	250			
	2375														5	475	237			
	2250														4	562	281			
	2205														4	550	275			
	2125														4	531	265			
	2080														4	520	260			
	2000														4	500	250			
	1955														4	488	244			
	1875														4	468	234			
		2		3														Number of infills per door section with glazing		
		2250	2375	2500	2750	3000	3250	3500	3750	4000	4250	4500	4750	5000						
		LZ																		

Doors up to 3000 × 2625 mm, with tension spring assembly

A No. of door sections

B Door section height

C Spacing

RM Grid height

LZ Clear frame dimensions (from 2000)

Special equipment

Ventilation

- Ventilation slots in bottom door section
ventilation cross section 65 cm² for one metre door width
- Ventilation slots in bottom door section
ventilation cross section 65 cm² for one metre door width
- Aluminium frame with expanded mesh
58 % ventilation cross section

Glazing options

- Aluminium frame (standard profile NF)
- Glazing type D, 3 mm

Sectional Door LTE 40

Single-skinned steel sections

S-panelled

Woodgrain

External views

(The illustrations correspond to size 2500 × 2125 mm. Deviations may occur with other door sizes.)

Basic model

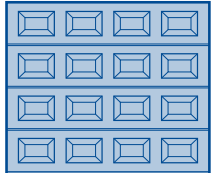

Style S0

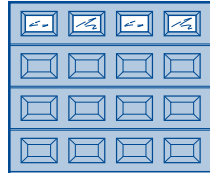

Style S1 with decorative rail (rhombus)

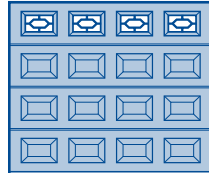

Style S2 with decorative rail (cross)

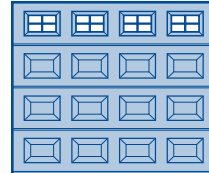

Style S10

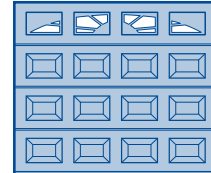

Size range

Door width in 5 mm increments, door height only in one of the grid heights shown. Intermediate heights are not possible.

														A	B	
RM	3000														6	500
	2875														6	479
	2750														5	550
	2625														5	525
	2500														5	500
	2375														5	475
	2250														4	562
	2205														4	550
	2125														4	531
	2080														4	520
	2000														4	500
	1955														4	488
	1875														4	468
			3 → 2070	4 → 2740	5										Number of panels per door section	
		2250	2375	2500	2750	3000	3250	3500	3750	4000	4250	4500	4750	5000		
		LZ														

Doors up to 3000 × 2625 mm, with tension spring assembly
A No. of door sections
B Door section height

RM Grid height
LZ Clear frame dimensions (from 2000)
 → Up to width

Special equipment

Ventilation

- Ventilation slots in bottom door section, ventilation cross section 65 cm² for one metre door width
- Ventilation slots in bottom door section, ventilation cross section 65 cm² for one metre door width

Glazing options – Panel glazing

Clear or crystal structure panes, 3 mm

- Designs S0, S1, S2
- Designs S10, S20 (see page 21)

Sectional Door EPU 40

Double-skinned steel sections

M-ribbed

Woodgrain

External views

(The illustrations correspond to size 2500 × 2125 mm. Deviations may occur with other door sizes.)

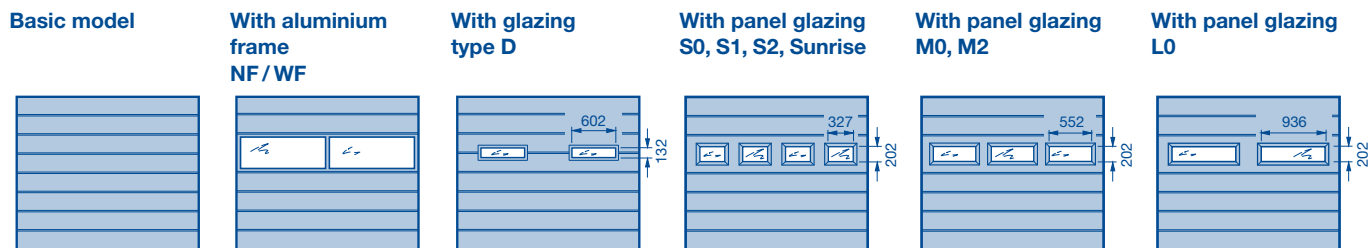

Size range

Door width in 5 mm increments, door height in grid height. Intermediate heights on request.

						A	B	C						
RM	3000							6	500	250				
	2875							6	479	239				
	2750							5	550	275				
	2625							5	525	262				
	2500							5	500	250				
	2375							5	475	237				
	2250							4	562	281				
	2205							4	550	275				
	2125							4	531	265				
	2080							4	520	260				
	2000							4	500	250				
	1955							4	488	244				
	1875							4	468	234				
										No. of ventilation grilles with 40 cm ² ventilation cross section each				
		4		6		8		10		No. of glazings – aluminium frame and type D				
		2		3		4		5		No. of glazings – type S				
3 → 2125		4		5		6		7		8				
2 → 2240		3 → 2970			4 → 3690			5 → 4420			6			
		2 → 3400				3 → 4490				4		No. of glazings – type L		
		2250	2375	2500	2750	3000	3250	3500	3750	4000	4250	4500	4750	5000
		LZ												

Doors up to 3000 × 2625 mm, with tension spring assembly

- A No. of door sections
- B Door section height
- C Spacing

- RM Grid height
- LZ Clear frame dimensions (from 2000)
- Up to width

Special equipment

Ventilation

- Ventilation slots in bottom door section
ventilation cross section 65 cm² for one metre door width
- Ventilation grille, ventilation cross section 40 cm² each
- Aluminium frame with expanded mesh
58 % ventilation cross section

Glazing options

- Aluminium frame (standard profile NF or thermal break profile WF)
- Glazing type D, 16 mm
- Panel glazing type S, 22 mm (see page 21)

Sectional Door EPU 40

Double-skinned steel sections

S-panelled

Woodgrain

External views

(The illustrations correspond to size 2500 × 2125 mm. Deviations may occur with other door sizes.)

Basic model

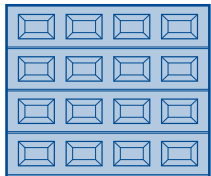

Style S0

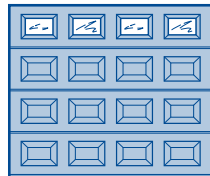

Style S1 with decorative rail (rhombus)

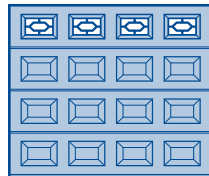

Style S2 with decorative rail (cross)

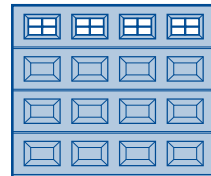

Style S10

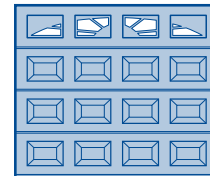

Size range

Door width in 5 mm increments, door height in grid height. Intermediate heights are not possible.

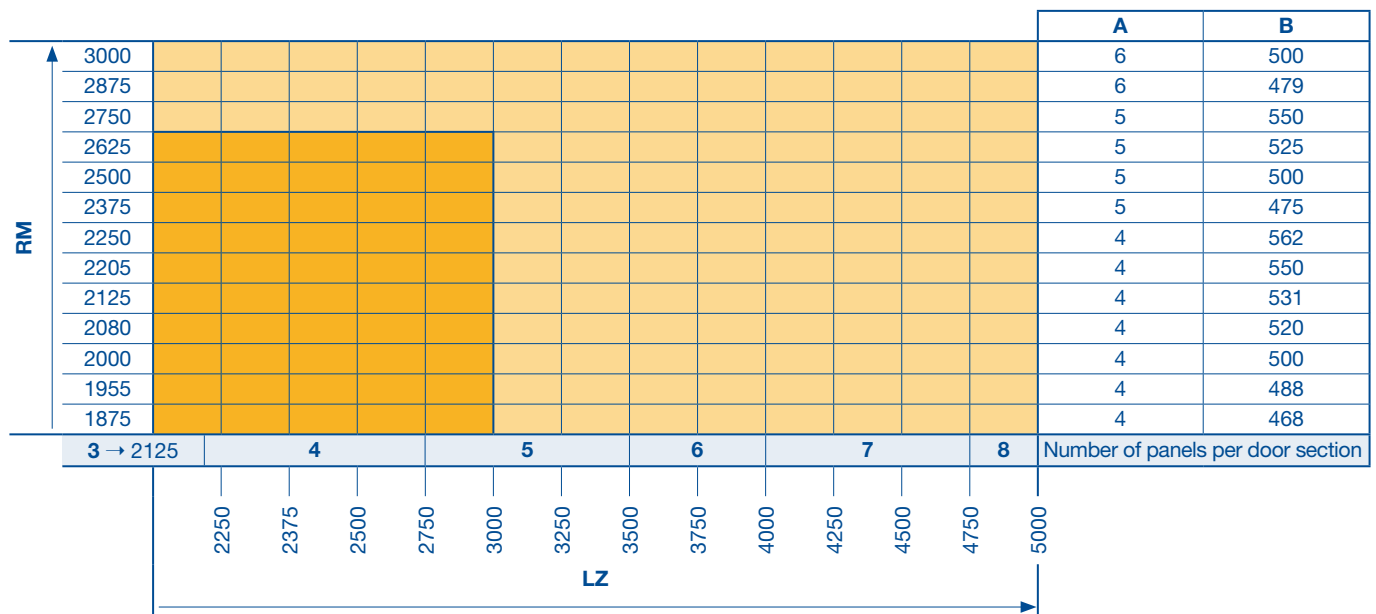

Doors up to 3000 × 2625 mm, with tension spring assembly
A No. of door sections
B Door section height

RM Grid height
LZ Clear frame dimensions (from 2000)
 → Up to width

Special equipment

Ventilation

- Ventilation slots in bottom door section
 ventilation cross section 65 cm² for one metre door width

Glazing options – Panel glazing

Clear or crystal structure double panes, 16 mm

- Styles S0, S1, S2
- Styles S10, S20, S30, S40, S50, S60 (see page 21)

Sectional Door LPU 40

Double-skinned steel sections

S-ribbed

Woodgrain

External views

(The illustrations correspond to size 2500 × 2125 mm. Deviations may occur with other door sizes.)

Basic model

With aluminium frame
NF / WF

With glazing
type D

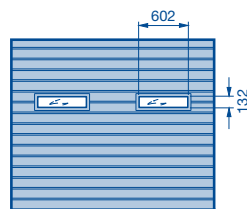
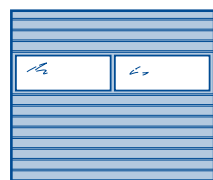
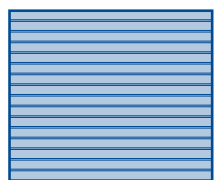

Size range

Door width in 5 mm increments up to LZ = 5500 mm, door height in grid height. Intermediate heights are possible.

							A	B	C											
RM	3000											6	500	125						
	2875											6	479	120						
	2750											5	550	138						
	2625											5	525	131						
	2500											5	500	125						
	2375											5	475	119						
	2250											4	562	141						
	2205											4	550	138						
	2125											4	531	133						
	2080											4	520	130						
	2000											4	500	125						
	1955											4	488	122						
	1875											4	468	117						
		4		6		8		10		12	No. of ventilation grilles with 40 cm ² ventilation cross section each									
		2		3		4		5		6	Number of infills per door section with glazing									
		2250	2375	2500	2750	3000	3250	3500	3750	4000	4250	4500	4750	5000	5250	5500	6000			
		LZ																		

Doors up to 3000 × 2625 mm, with tension spring assembly

A No. of door sections

B Door section height

C Spacing

RM Grid height

LZ Clear frame dimensions (from 2000)

Special equipment

Ventilation

- Ventilation slots in bottom door section
ventilation cross section 65 cm² for one metre door width
- Ventilation grille, ventilation cross section 40 cm² each
- Aluminium frame with expanded mesh
58 % ventilation cross section

Glazing options

- Aluminium frame (standard profile NF or thermal break profile WF)
- Glazing type D, 16 mm

Sectional Door LPU 40

Double-skinned steel sections

M-ribbed

Woodgrain

External views

(The illustrations correspond to size 2500 × 2125 mm. Deviations may occur with other door sizes.)

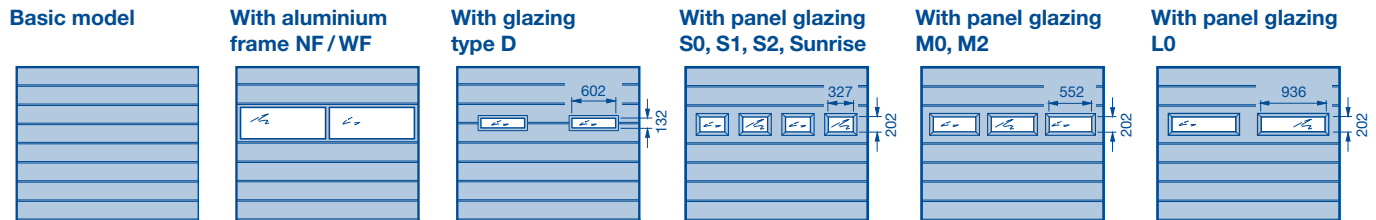

Size range

Door width in 5 mm increments up to LZ = 5500 mm, door height in grid height. Intermediate heights are possible.

													A	B	C		
RM	3000												6	500	250		
	2875												6	479	239		
	2750												5	550	275		
	2625												5	525	262		
	2500												5	500	250		
	2375												5	475	237		
	2250												4	562	281		
	2205												4	550	275		
	2125												4	531	265		
	2080												4	520	260		
	2000												4	500	250		
	1955												4	488	244		
	1875												4	468	234		
		4		6		8		10		12		No. of ventilation grilles with 40 cm ² ventilation cross section each					
		2		3		4		5		6		No. of glazings – aluminium frame and type D					
3 → 2125		4		5		6		7		8		9		No. of glazings – type S			
2 → 2240		3 → 2970		4 → 3690		5 → 4420		6 → 5140		7		8		No. of glazings – type M			
		2 → 3400		3 → 4490		4		5				5		No. of glazings – type L			
		2250	2375	2500	2750	3000	3250	3500	3750	4000	4250	4500	4750	5000	5250	5500	6000
		LZ															

Doors up to 3000 × 2625 mm, with tension spring assembly

- A No. of door sections
- B Door section height
- C Spacing

- RM Grid height
- LZ Clear frame dimensions (from 2000)
- Up to width

Special equipment

Ventilation

- Ventilation slots in bottom door section ventilation cross section 65 cm² for one metre door width
- Ventilation grille, ventilation cross section 40 cm² each
- Aluminium frame with expanded mesh 58 % ventilation cross section

Glazing options

- Aluminium frame (standard profile NF or thermal break profile WF)
- Glazing type D, 16 mm
- Panel glazing type S, 22 mm (see page 21)

Sectional Door LPU 40

Double-skinned steel sections

M-ribbed

Silkgrain

External views

(The illustrations correspond to size 2500 × 2125 mm. Deviations may occur with other door sizes.)

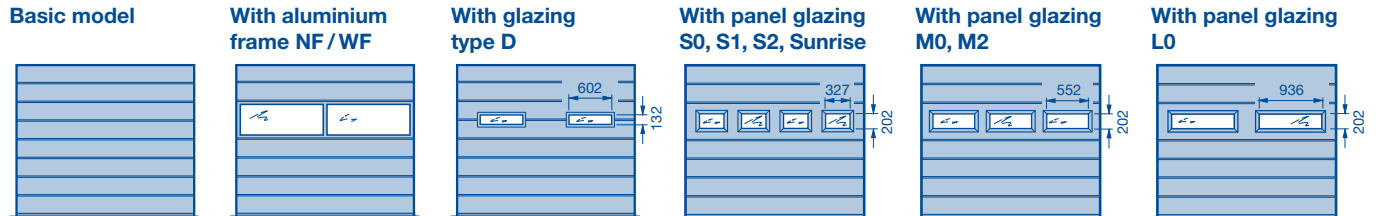

Size range

Door width in 5 mm increments up to LZ = 5500 mm, door height in grid height. Intermediate heights are possible.

													A	B	C				
RM	3000												6	500	250				
	2875																		
	2750												5	550	275				
	2625																		
	2500												5	500	250				
	2375												5	475	237				
	2250												4	562	281				
	2205												4	550	275				
	2125												4	531	265				
	2080												4	520	260				
	2000												4	500	250				
	1955												4	488	244				
	1875												4	468	234				
	4				6				8				10			12		No. of ventilation grilles with 40 cm ² ventilation cross section each	
	2		3		4		5		6			7			8		No. of ventilations – aluminium frame and type D		
	3 → 2125		4		5		6		7			8			9		No. of ventilations – type S		
	2 → 2240		3 → 2970			4 → 3690			5 → 4420			6 → 5140			7		8		No. of ventilations – type M
	2 → 3400				3 → 4490				4				5			No. of ventilations – type L			
	2250	2375	2500	2750	3000	3250	3500	3750	4000	4250	4500	4750	5000	5250	5500	6000	LZ		

Doors up to 3000 × 2625 mm, with tension spring assembly

- A No. of door sections
- B Door section height
- C Spacing

- RM Grid height
- LZ Clear frame dimensions (from 2000)
- Up to width

Special equipment

Ventilation

- Ventilation slots in bottom door section
ventilation cross section 65 cm² for one metre door width
- Ventilation grille, ventilation cross section 40 cm² each
- Aluminium frame with expanded mesh
58 % ventilation cross section

Glazing options

- Aluminium frame (standard profile NF or thermal break profile WF)
- Glazing type D, 16 mm
- Panel glazing type S, 22 mm (see page 21)

Sectional Door LPU 40

Double-skinned steel sections

M-ribbed

Micrograin

External views

(The illustrations correspond to size 2500 × 2125 mm. Deviations may occur with other door sizes.)

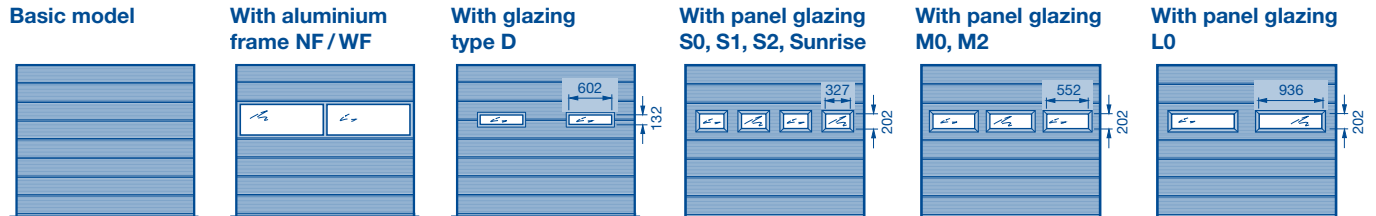

Size range

Door width in 5 mm increments up to LZ = 5500 mm, door height in grid height. Intermediate heights are possible.

														A	B	C				
RM	3000													6	500	250				
	2875																			
	2750													5	550	275				
	2625																			
	2500													5	500	250				
	2375													5	475	237				
	2250													4	562	281				
	2205													4	550	275				
	2125													4	531	265				
	2080													4	520	260				
	2000													4	500	250				
	1955													4	488	244				
1875													4	468	234					
		4			6			8			10			12	No. of ventilation grilles with 40 cm ² ventilation cross section each					
		2		3		4		5		6		7		8	No. of ventilations – aluminium frame and type D					
3 → 2125		4		5		6		7		8		9		No. of ventilations – type S						
2 → 2240		3 → 2970			4 → 3690			5 → 4420			6 → 5140		7		8					
		2 → 3400				3 → 4490				4				5		No. of ventilations – type L				
		2250	2375	2500	2750	3000	3250	3500	3750	4000	4250	4500	4750	5000	5250	5500	6000	LZ		

- Doors up to 3000 × 2625 mm, with tension spring assembly
- A** No. of door sections
- B** Door section height
- C** Spacing

- RM** Grid height
- LZ** Clear frame dimensions (from 2000)
- Up to width

Special equipment

Ventilation

- Ventilation slots in bottom door section ventilation cross section 65 cm² for one metre door width
- Ventilation grille, ventilation cross section 40 cm² each
- Aluminium frame with expanded mesh 58 % ventilation cross section

Glazing options

- Aluminium frame (standard profile NF or thermal break profile WF)
- Glazing type D, 16 mm
- Panel glazing type S, 22 mm (see page 21)

Sectional Door LPU 40

Double-skinned steel sections

M-ribbed

Decrain

External views

(The illustrations correspond to size 2500 × 2125 mm. Deviations may occur with other door sizes.)

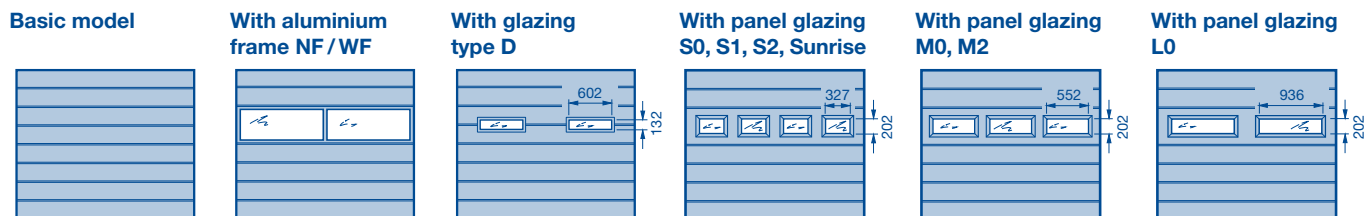

Size range

Door width in 5 mm increments up to LZ = 5500 mm, door height in grid height. Intermediate heights are possible.

												A	B	C			
RM	3000											6	500	250			
	2875																
	2750											5	550	275			
	2625																
	2500											5	500	250			
	2375											5	475	237			
	2250											4	562	281			
	2205											4	550	275			
	2125											4	531	265			
	2080											4	520	260			
	2000											4	500	250			
1955											4	488	244				
1875											4	468	234				
	4		6		8		10		12		No. of ventilation grilles with 40 cm ² ventilation cross section each						
	2		3		4		5		6		No. of glazings – aluminium frame and type D						
	3 → 2125	4		5		6		7		8		9		No. of glazings – type S			
	2 → 2240	3 → 2970			4 → 3690		5 → 4420		6 → 5140		7		8		No. of glazings – type M		
		2 → 3400				3 → 4490			4		5		No. of glazings – type L				
		2250	2375	2500	2750	3000	3250	3500	3750	4000	4250	4500	4750	5000	5250	5500	6000
		LZ															

Doors up to 3000 × 2625 mm, with tension spring assembly

- A No. of door sections
- B Door section height
- C Spacing

- RM Grid height
- LZ Clear frame dimensions (from 2000)
- Up to width

Special equipment

Ventilation

- Ventilation slots in bottom door section ventilation cross section 65 cm² for one metre door width
- Ventilation grille, ventilation cross section 40 cm² each
- Aluminium frame with expanded mesh 58 % ventilation cross section

Glazing options

- Aluminium frame (standard profile NF or thermal break profile WF)
- Glazing type D, 16 mm
- Panel glazing type S, 22 mm (see page 21)

Sectional Door LPU 40

Double-skinned steel sections

L-ribbed

Woodgrain

External views

(The illustrations correspond to size 2500 × 2125 mm. Deviations may occur with other door sizes.)

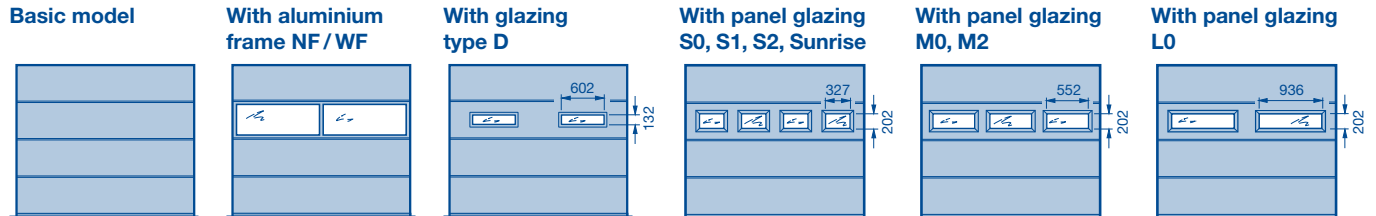

Size range

Door width in 5 mm increments up to LZ = 5500 mm, door height in grid height. Intermediate heights are possible.

													A	B			
RM	3000												6	500			
	2875												6	479			
	2750												5	550			
	2625												5	525			
	2500												5	500			
	2375												5	475			
	2250												4	562			
	2205												4	550			
	2125												4	531			
	2080												4	520			
	2000												4	500			
	1955												4	488			
	1875												4	468			
	4		6			8			10			12	No. of ventilation grilles with 40 cm ² ventilation cross section each				
	3		3			4			5			6	No. of glazings – aluminium frame and type D				
	3 → 2125	4		5		6		7		8		9	No. of glazings – type S				
	2 → 2240	3 → 2970			4 → 3690			5 → 4420			6 → 5140		7	8			
		2 → 3400				3 → 4490				4		5		No. of glazings – type L			
		2250	2375	2500	2750	3000	3250	3500	3750	4000	4250	4500	4750	5000	5250	5500	6000
		LZ															

Doors up to 3000 × 2625 mm, with tension spring assembly

A No. of door sections
B Door section height

RM Grid height
LZ Clear frame dimensions (from 2000)
→ Up to width

Special equipment

Ventilation

- Ventilation slots in bottom door section ventilation cross section 65 cm² for one metre door width
- Ventilation grille, ventilation cross section 40 cm² each
- Aluminium frame with expanded mesh 58 % ventilation cross section

Glazing options

- Aluminium frame (standard profile NF or thermal break profile WF)
- Glazing type D, 16 mm
- Panel glazing type S, 22 mm (see page 21)

Sectional Door LPU 40

Double-skinned steel sections

L-ribbed

Silkgrain

External views

(The illustrations correspond to size 2500 × 2125 mm. Deviations may occur with other door sizes.)

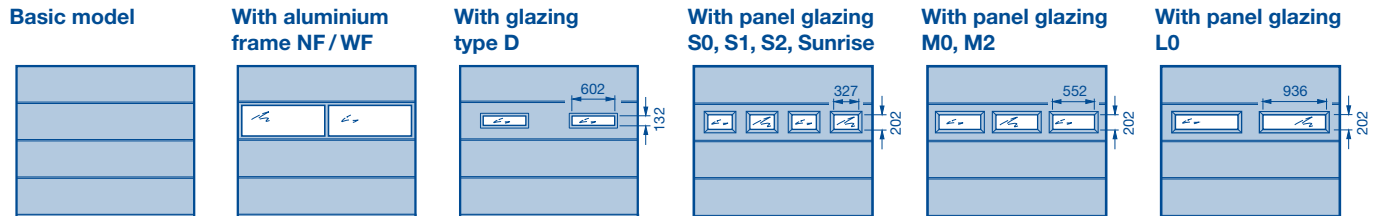

Size range

Door width in 5 mm increments up to LZ = 5500 mm, door height in grid height. Intermediate heights are possible.

												A	B						
RM	3000											6	500						
	2875																		
	2750											5	550						
	2625																		
	2500											5	500						
	2375											5	475						
	2250											4	562						
	2205											4	550						
	2125											4	531						
	2080											4	520						
	2000											4	500						
	1955											4	488						
	1875											4	468						
	4		6			8			10		12	No. of ventilation grilles with 40 cm ² ventilation cross section each							
	2		3			4			5		6	No. of glazings – aluminium frame and type D							
	3 → 2125		4		5		6		7		8		9		No. of glazings – type S				
	2 → 2240		3 → 2970			4 → 3690			5 → 4420			6 → 5140		7		8		No. of glazings – type M	
			2 → 3400			3 → 4490			4			5		No. of glazings – type L					
		2250	2375	2500	2750	3000	3250	3500	3750	4000	4250	4500	4750	5000	5250	5500	6000	LZ	

Doors up to 3000 × 2625 mm, with tension spring assembly

A No. of door sections

B Door section height

RM Grid height

LZ Clear frame dimensions (from 2000)

→ Up to width

Special equipment

Ventilation

- Ventilation slots in bottom door section
ventilation cross section 65 cm² for one metre door width
- Ventilation grille, ventilation cross section 40 cm² each
- Aluminium frame with expanded mesh
58 % ventilation cross section

Glazing options

- Aluminium frame (standard profile NF or thermal break profile WF)
- Glazing type D, 16 mm
- Panel glazing type S, 22 mm (see page 21)

Sectional Door LPU 40

Double-skinned steel sections

L-ribbed

Micrograin

External views

(The illustrations correspond to size 2500 × 2125 mm. Deviations may occur with other door sizes.)

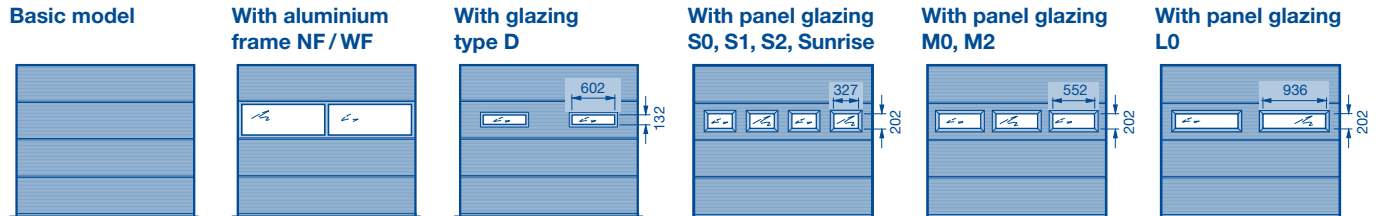

Size range

Door width in 5 mm increments up to LZ = 5500 mm, door height in grid height. Intermediate heights are possible.

													A	B																		
RM	3000												6	500																		
	2875																															
	2750												5	550																		
	2625																															
	2500												5	500																		
	2375												5	475																		
	2250												4	562																		
	2205												4	550																		
	2125												4	531																		
	2080												4	520																		
	2000												4	500																		
	1955												4	488																		
	1875												4	468																		
	4				6				8				10			12	No. of ventilation grilles with 40 cm ² ventilation cross section each															
	2		3		4				5			6		No. of ventilations – aluminium frame and type D																		
	3 → 2125		4		5			6		7		8		9		No. of ventilations – type S																
	2 → 2240		3 → 2970			4 → 3690			5 → 4420			6 → 5140		7		8		No. of ventilations – type M														
	2 → 3400				3 → 4490				4			5		No. of ventilations – type L																		
	2250		2375		2500		2750		3000		3250		3500		3750		4000		4250		4500		4750		5000		5250		5500		6000	
	LZ																															

Doors up to 3000 × 2625 mm, with tension spring assembly

A No. of door sections

B Door section height

RM Grid height

LZ Clear frame dimensions (from 2000)

→ Up to width

Special equipment

Ventilation

- Ventilation slots in bottom door section ventilation cross section 65 cm² for one metre door width
- Ventilation grille, ventilation cross section 40 cm² each
- Aluminium frame with expanded mesh 58 % ventilation cross section

Glazing options

- Aluminium frame (standard profile NF or thermal break profile WF)
- Glazing type D, 16 mm
- Panel glazing type S, 22 mm (see page 21)

Sectional Door LPU 40

Double-skinned steel sections

L-ribbed

Decrain

External views

(The illustrations correspond to size 2500 × 2125 mm. Deviations may occur with other door sizes.)

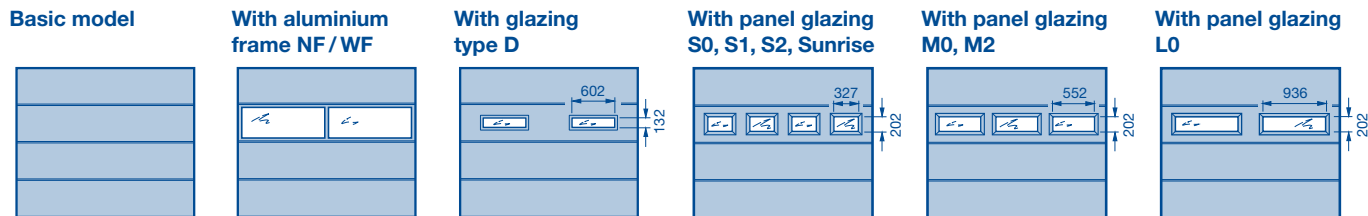

Size range

Door width in 5 mm increments up to LZ = 5500 mm, door height in grid height. Intermediate heights are possible.

												A	B			
RM	3000											6	500			
	2875															
	2750											5	550			
	2625															
	2500											5	500			
	2375											5	475			
	2250											4	562			
	2205											4	550			
	2125											4	531			
	2080											4	520			
	2000											4	500			
	1955											4	488			
	1875											4	468			
	4		6		8		10		12		No. of ventilation grilles with 40 cm ² ventilation cross section each					
	2		3		4		5		6		No. of glazings – aluminium frame and type D					
	3 → 2125		4		5		6		7		8					
	2 → 2240		3 → 2970		4 → 3690		5 → 4420		6 → 5140		7					
			2 → 3400		3 → 4490		4		5		No. of glazings – type L					
	2250	2375	2500	2750	3000	3250	3500	3750	4000	4250	4500	4750	5000	5250	5500	6000
	LZ															

Doors up to 3000 × 2625 mm, with tension spring assembly

A No. of door sections

B Door section height

RM Grid height

LZ Clear frame dimensions (from 2000)

→ Up to width

Special equipment

Ventilation

- Ventilation slots in bottom door section
ventilation cross section 65 cm² for one metre door width
- Ventilation grille, ventilation cross section 40 cm² each
- Aluminium frame with expanded mesh
58 % ventilation cross section

Glazing options

- Aluminium frame (standard profile NF or thermal break profile WF)
- Glazing type D, 16 mm
- Panel glazing type S, 22 mm (see page 21)

Sectional Door LPU 40

Double-skinned steel sections

S-panelled

Woodgrain

External views

(The illustrations correspond to size 2500 × 2125 mm. Deviations may occur with other door sizes.)

Basic model

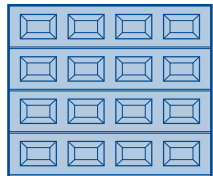

Style S0

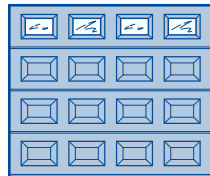

Style S1 with decorative rail (rhombus)

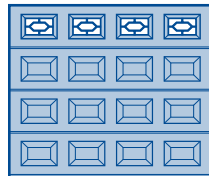

Style S2 with decorative rail (cross)

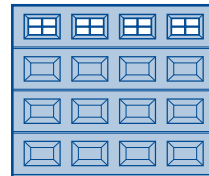

Style S10

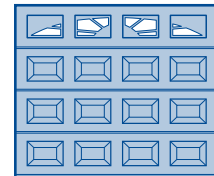

Size range

Door width in 5 mm increments, door height in grid height. Intermediate heights are not possible.

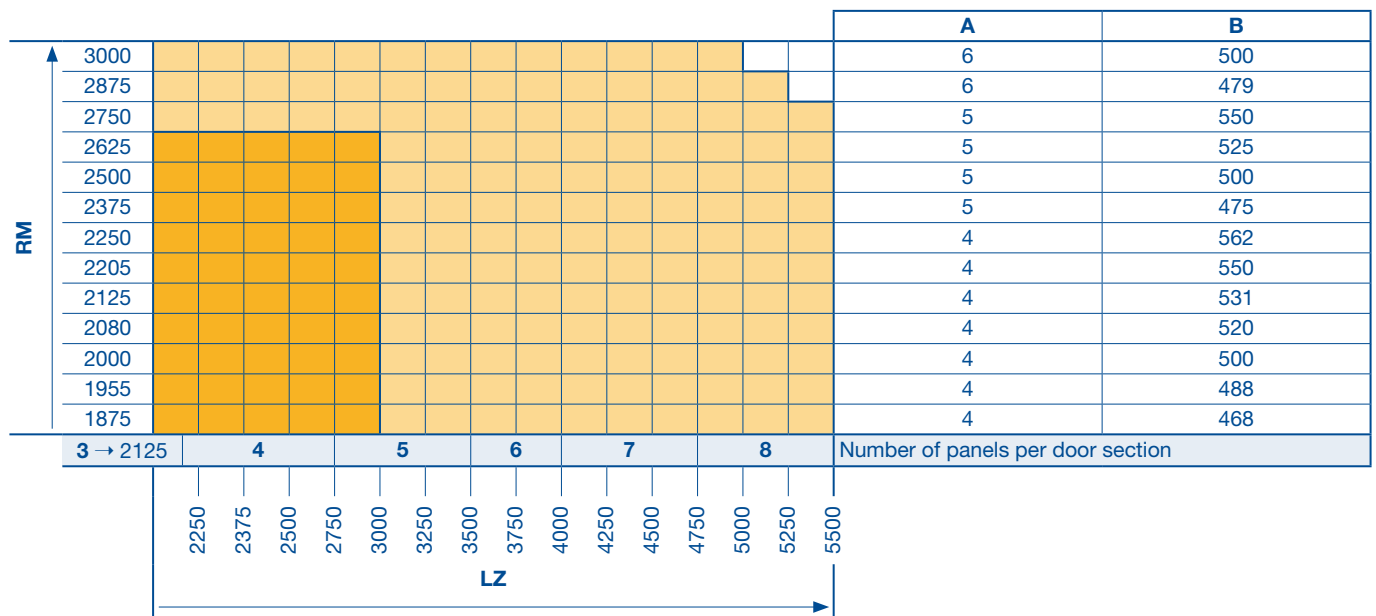

Doors up to 3000 × 2625 mm, with tension spring assembly

A No. of door sections

B Door section height

RM Grid height

LZ Clear frame dimensions (from 2000)

→ Up to width

Special equipment

Ventilation

- Ventilation slots in bottom door section
ventilation cross section 65 cm² for one metre door width

Glazing options – Panel glazing

Clear or crystal structure double panes, 16 mm

- Styles S0, S1, S2
- Styles S10, S20, S30, S40, S50, S60 (see page 21)

Sectional Door LPU 40

Double-skinned steel sections

S-panelled

Decograin

External views

(The illustrations correspond to size 2500 × 2125 mm. Deviations may occur with other door sizes.)

Basic model

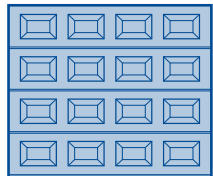

Style S0

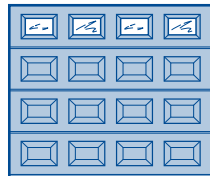

Style S1 with decorative rail (rhombus)

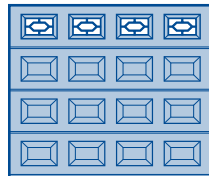

Style S2 with decorative rail (cross)

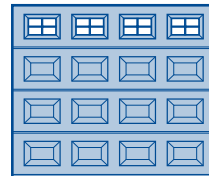

Style S10

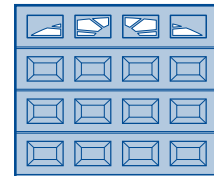

Size range

Door width in 5 mm increments, door height in grid height. Intermediate heights are not possible.

												A	B						
RM	3000											6	500						
	2875																		
	2750																		
	2625																		
	2500											5	500						
	2375											5	475						
	2250											4	562						
	2205																		
	2125											4	531						
	2080																		
	2000											4	500						
	1955																		
	1875											4	468						
		3 → 2125	4	5	6	7	8	Number of panels per door section											
			2250	2375	2500	2750	3000	3250	3500	3750	4000	4250	4500	4750	5000	5250	5500		
		LZ																	

Doors up to 3000 × 2625 mm, with tension spring assembly

A No. of door sections

B Door section height

RM Grid height

LZ Clear frame dimensions (from 2000)

→ Up to width

Special equipment

Ventilation

- Ventilation slots in bottom door section
ventilation cross section 65 cm² for one metre door width

Glazing options – Panel glazing

Clear or crystal structure double panes, 16 mm

- Styles S0, S1, S2
- Styles S10, S20, S30, S40, S50, S60 (see page 21)

Sunrise Glazing

For sectional doors

LTE 40 / EPU 40 / LPU 40

External views

Sunrise glazing for sectional doors LTE / EPU / LPU 40 for standard and special sizes

Glazing options for S-panelled type (not possible for doors with 3 panels for each section)

Style S10

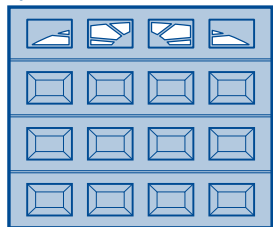

Style S20

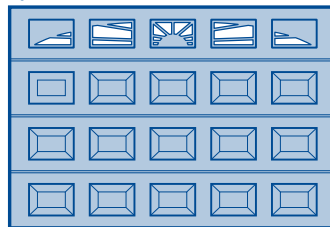

Style S30

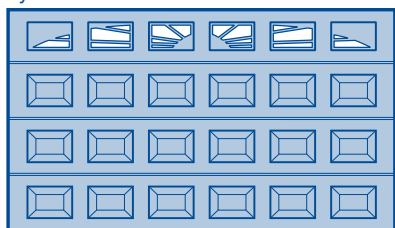

Style S40

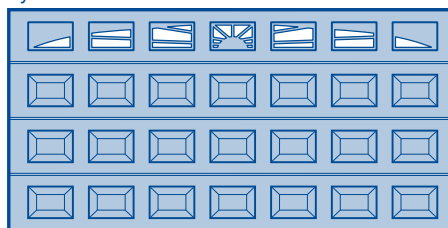

Style S50

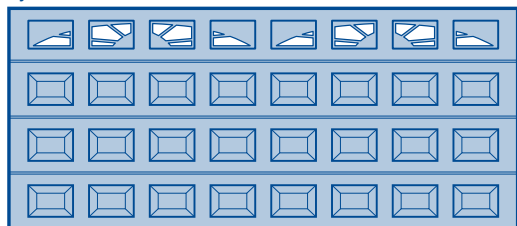

Style S60

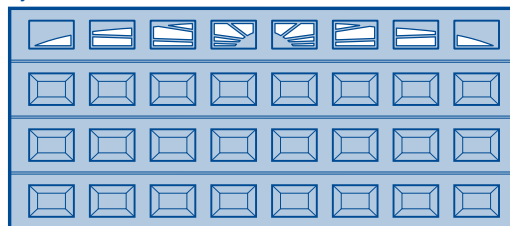

Design Element

For sectional doors

LPU 40, L-ribbed

Silkgrain

External views

Door view

2500 × 2125 mm

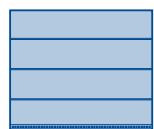

Style 450



Style 451 / 461¹⁾

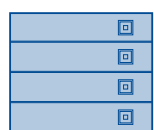

Style 452 / 462¹⁾



Style 454



Style 456



Style 457

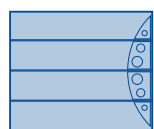

Style 458



Style 459 / 469¹⁾

Door view

5000 × 2125 mm

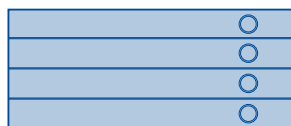
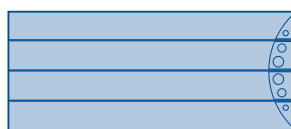
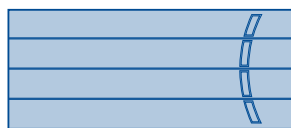
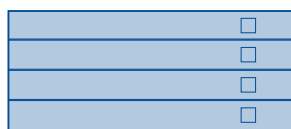
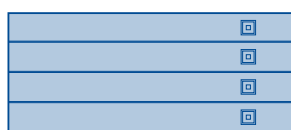
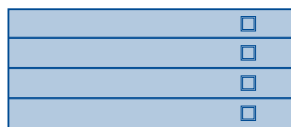
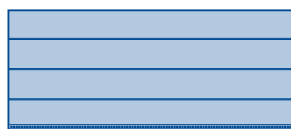

Side door view

1000 × 2125 mm



Similar to entrance door 693



Similar to entrance door 173



Similar to entrance door 866



Similar to entrance door 188



1) Glazing with double pane

Sectional Door LPU 40 with Wicket Door

Double-skinned steel sections

S-ribbed, M-ribbed, L-ribbed

Woodgrain, Micrograin or Decograin

Matching external view for doors with glazing

External views External views

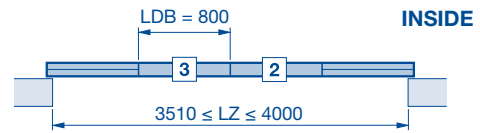
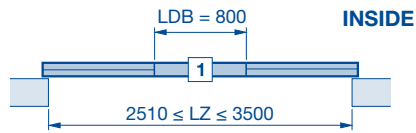

Glazing type D



Glazing type D

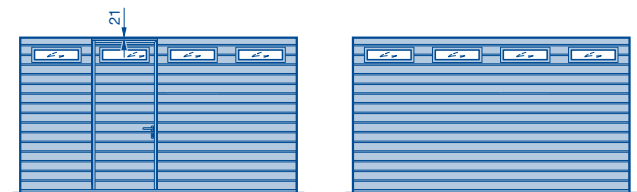

Glazing type S



Glazing type S



Glazing type M



Glazing type M



Aluminium frame NF / WF

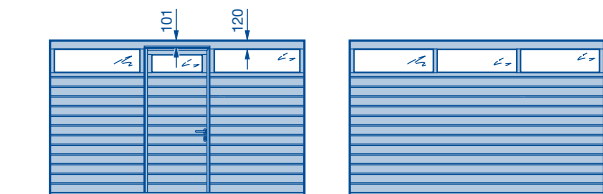

Aluminium frame NF / WF



The illustrations correspond to door height 2125 mm and arrangement 3.

Sectional Door LPU 40 with Wicket Door

Double-skinned steel sections

S-panelled

Woodgrain / Decograin

External views

(The illustrations correspond to size 2500 × 2125 mm. Deviations may occur with other door sizes. Due to the low threshold height, the ground in front of the garage must be level or sloped to guarantee smooth opening of the wicket door (opening outwards) – see page 47.)

Basic model

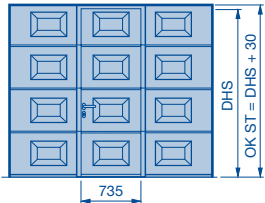

Style S0

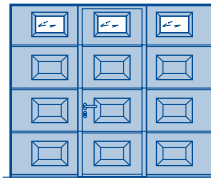

Style S1 with decorative rail (rhombus)

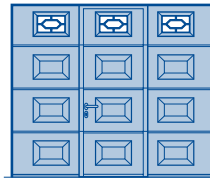

Style S2 with decorative rail (cross)

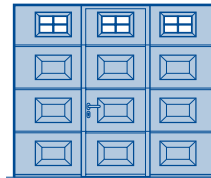

Wicket doors

The wicket doors are always in four parts. The clear passage width of the wicket door is 735 mm and the threshold height starts at 5 mm and increases to 10 mm.

Size range

Door width in 5 mm increments, door height only in grid height. Intermediate heights are not possible. See track applications for the ceiling height and clear passage (pages 38–39).

		A	B	C	DRH								
RM	3000	6	500	1955	831								
	2875	•	•	•	•	6	479	1871	799				
	2750	•	•	•	•	•	•	•	5	550	2155	906	
	2625	•	•	•	•	•	•	•	•	5	525	2055	868
	2500									5	500	1955	831
	2375									5	475	1855	793
	2250									4	562	2203	924
	2205	•	•	•	•	•	•	•	•	4	550	2155	906
	2125									4	531	2079	877
	2080	•	•	•	•	•	•	•	•	4	520	2035	861
	2000									4	500	1955	831
	1955	•	•	•	•	•	•	•	•	4	488	1907	813
		3	4	5	Numbers of panels / panel glazings per door section								
LZ		2500	2750	3000	3250	3500	3750	4000					

- A** No. of door sections
- B** Door section height
- C** Clear passage height of wicket door (DHS)
- DRH** Lever height
- RM** Grid height
- LZ** Clear frame dimensions (from 2250)
- OK ST** Top edge of wicket door
- Up to width
- Grid heights RM not possible with Decograin

Note:

With 4 panels, the wicket door is set off-centre!
Sectional door with wicket door only possible with track application N or L!

Note:

For doors up to RM 2250, the distance from FFL to the bottom edge of the lintel must be equal to or greater than the ordering size (RM).

Special equipment

Glazing options – Panel glazing

Clear or crystal structure double panes, 16 mm

- Design S0
- Design S1
- Design S2
- Designs S10, S20 (see page 21)
- With wicket door multiple-point locking, glazings above the wicket door possible (from 5th section from the bottom)
- With integrated overhead door closer, glazing type S, M, NF & WF not possible, possible in the 4th wicket door section (only left and right next to the ST)

Sectional Door LPU 40 with Wicket Door

Arrangement of the wicket door

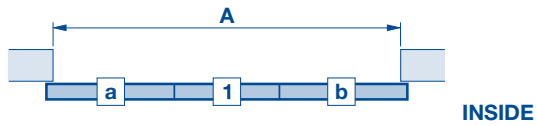

Note:

Arrangement “a” and “b” only if S, M and L-ribbed without glazing. 500 mm fixed distance from the edge.

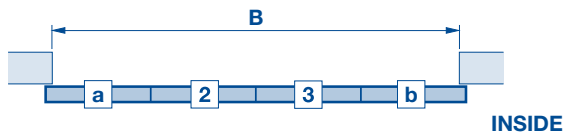

Note:

Wicket door only opening outwards.

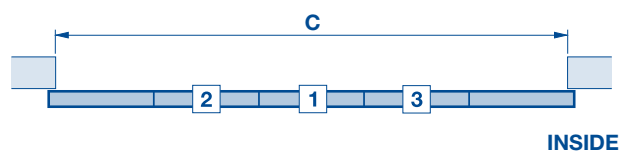

	A	B	C
Sectional door S, M or L-ribbed	2250 – 3500	3510 – 4000	–
Sectional door, S-panelled	2250 – 2500	2505 – 3250	3255 – 4000

Sectional Door LTH 40

S-ribbed, V-panelled
Nordic Pine / Hemlock

External views

(The illustrations correspond to size 2500 × 2125 mm. Deviations may occur with other door sizes.)

Basic model
S-ribbed

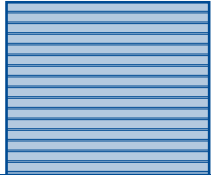

Basic model
M-ribbed



Basic model
L-ribbed



Basic model
V-panelled

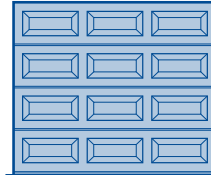

With glazing V0

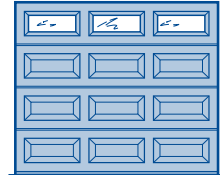

Size range

Door width in 10 mm increments. Intermediate heights are possible for V-panelled versions (on request for S-ribbed versions).

RM	LZ												S-ribbed			V-panelled	
	3			4			5			6			A	B	C	A	
3000														6	500	125	6
2875														6	479	120	6
2750														5	550	138	6
2625														5	525	131	5
2500														5	500	125	5
2375														5	475	119	5
2250														4	562	141	5
2125														4	531	133	4
2000														4	500	125	4
1875														4	468	117	4

Numbers of panels / panel glazings per door section

Note:
Sectional door LTH 40 only with torsion spring assembly

A No. of door sections
B Door section height
C Spacing

RM Grid height
LZ Clear frame dimensions (from 2000)

Ventilation

- Ventilation slots in bottom seal (standard), ventilation cross section 65 cm² for one metre door width

Glazing options (for panelled versions only)

- Panel glazing with clear or crystal structure, 3 mm

Sectional Door LTH 40 with Special Designs

Nordic Pine / Hemlock

External views

Style 401

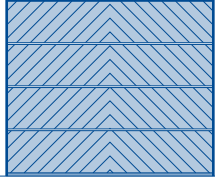

Style 402

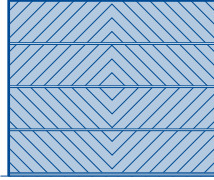

Style 403

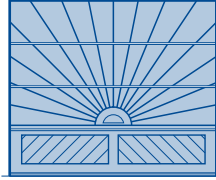

Style 404

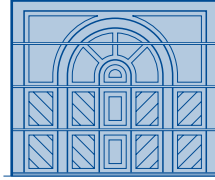

Style 405

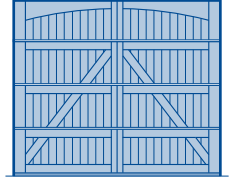

Style 401

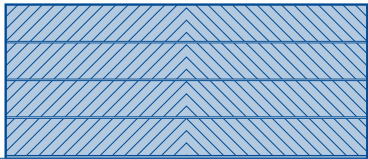

Style 402

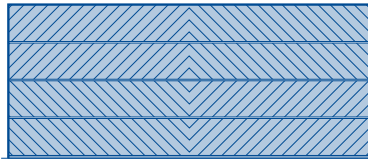

Style 403

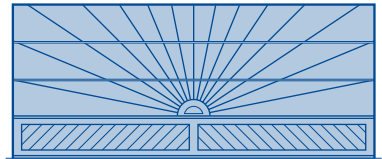

Style 404



Style 405

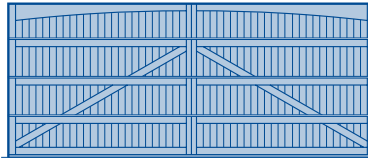

The illustrations correspond to the proportions for size 2500 × 2125 mm (top row) as well as the sizes 5000 × 2125 mm (centre and bottom row). Deviations may occur with other sizes.

Size range

Door width in 10 mm increments. Intermediate heights are possible. Further designs on request.

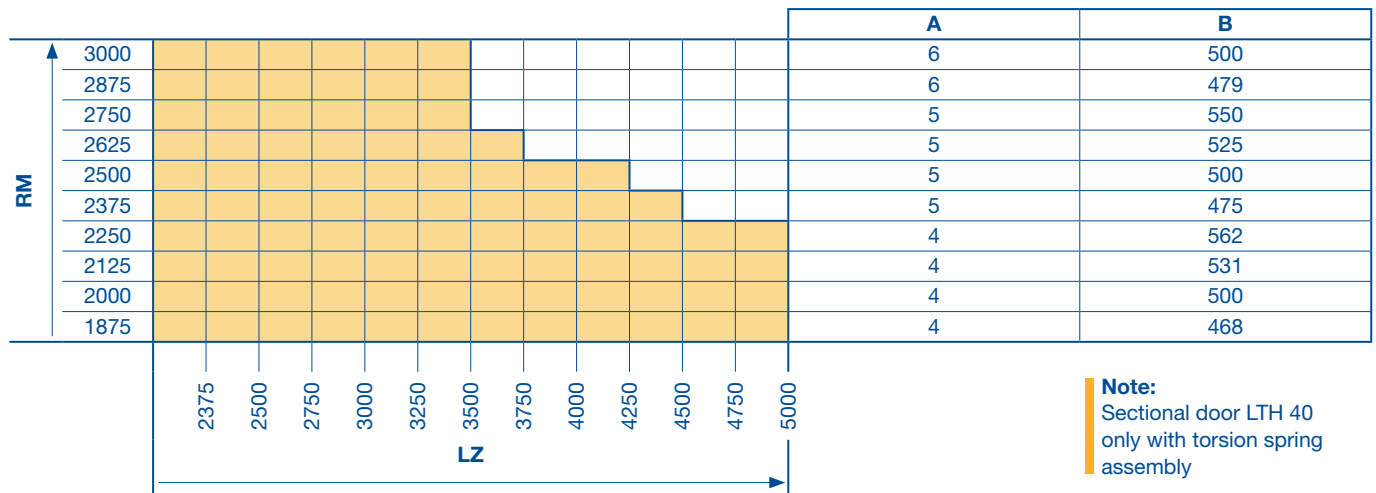

Note:
Sectional door LTH 40 only with torsion spring assembly

A No. of door sections
B Door section height
RM Grid height

LZ Clear frame dimensions (from 2250)

Ventilation

- Ventilation slots in bottom seal (standard), ventilation cross section 65 cm² for one metre door width

Sectional Door LPU 40

Double-skinned steel sections, fitting in front of the reveal

S-ribbed

Woodgrain

External views

(The illustrations correspond to size 2500 × 2125 mm. Deviations may occur with other door sizes.)

Basic model

With aluminium frame
NF / WF

With glazing
type D

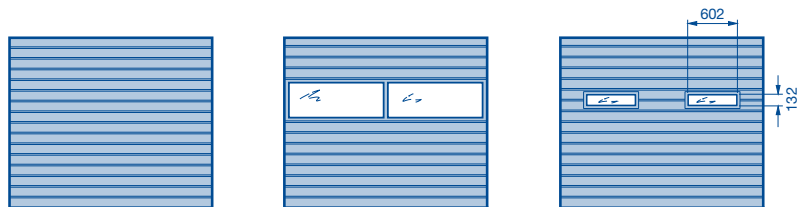

Size range

Door width in 5 mm increments, door height in grid height. Intermediate heights are possible.

													A	B	C		
RM	2205												4	550	138		
	2125												4	531	133		
	2080												4	520	130		
	2000												4	500	125		
	1955												4	488	122		
	1875												4	468	117		
		4	6										No. of ventilation grilles with 40 cm ² ventilation cross section each				
		2	3										Number of infills per door section with glazing				
		2250	2375	2500	2750	3000	3250	3500	3750	4000	4250	4500	4750	5000			
		LZ															

Doors up to 3000 × 2500 mm, with tension spring assembly

A No. of door sections

B Door section height

C Spacing

RM Grid height

LZ Clear frame dimensions (from 2000)

Special equipment

Ventilation

- Ventilation slots in bottom seal
ventilation cross section 65 cm² for one metre door width
- Ventilation grille, ventilation cross section 40 cm² each
- Aluminium frame with expanded mesh
58 % ventilation cross section

Glazing options

- Aluminium frame (standard profile NF or thermal break profile WF)
- Glazing type D, 16 mm

Sectional Door LPU 40

Double-skinned steel sections, fitting in front of the reveal

M-ribbed

Woodgrain

External views

(The illustrations correspond to size 2500 × 2125 mm. Deviations may occur with other door sizes.)

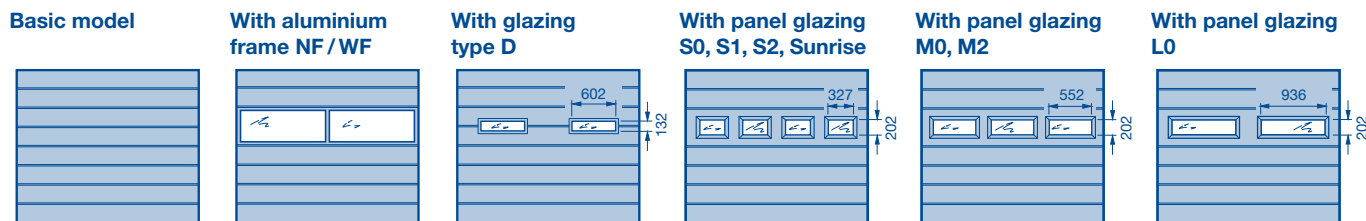

Size range

Door width in 5 mm increments, door height in grid height. Intermediate heights are possible.

														A	B	C	
RM	2205													4	550	275	
	2125													4	531	265	
	2080													4	520	260	
	2000													4	500	250	
	1955													4	488	244	
	1875													4	468	234	
		4	6											No. of ventilation grilles with 40 cm ² ventilation cross section each			
		2	3											No. of glazings – aluminium frame and type D			
3 → 2125		4	5											No. of glazings – type S			
2 → 2240		3												No. of glazings – type M			
		2												No. of glazings – type L			
		2250	2375	2500	2750	3000	3250	3500	3750	4000	4250	4500	4750	5000	LZ		

- A No. of door sections
- B Door section height
- C Spacing
- RM Grid height

- LZ Clear frame dimensions (from 2000)
- Up to width

Special equipment

Ventilation

- Ventilation slots in bottom seal
ventilation cross section 65 cm² for one metre door width
- Ventilation grille, ventilation cross section 40 cm² each
- Aluminium frame with expanded mesh
58 % ventilation cross section

Glazing options

- Aluminium frame (standard profile NF or thermal break profile WF)
- Glazing type D, 16 mm
- Panel glazing type S, 22 mm (see page 21)

Sectional Door LPU 40

Double-skinned steel sections, fitting in front of the reveal

M-ribbed

Silkgrain

External views

(The illustrations correspond to size 2500 × 2125 mm. Deviations may occur with other door sizes.)

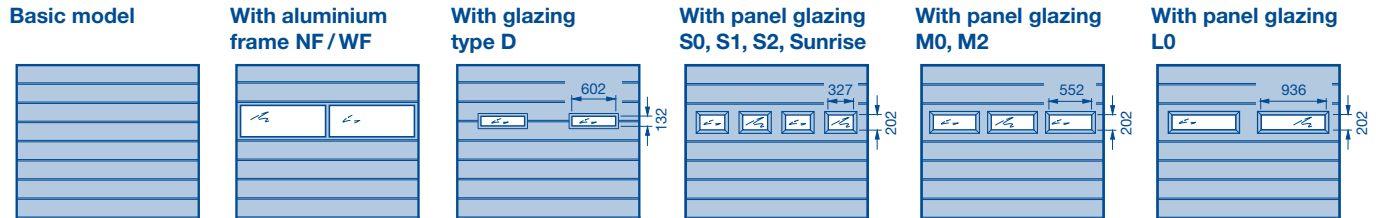

Size range

Door width in 5 mm increments, door height in grid height. Intermediate heights are possible.

														A	B	C	
RM	2205													4	550	275	
	2125													4	531	265	
	2080													4	520	260	
	2000													4	500	250	
	1955													4	488	244	
	1875													4	468	234	
		4	6											No. of ventilation grilles with 40 cm ² ventilation cross section each			
		2	3											No. of glazings – aluminium frame and type D			
3 → 2125		4	5											No. of glazings – type S			
2 → 2240		3												No. of glazings – type M			
		2												No. of glazings – type L			
		2250	2375	2500	2750	3000	3250	3500	3750	4000	4250	4500	4750	5000	LZ		

- A No. of door sections
- B Door section height
- C Spacing
- RM Grid height

- LZ Clear frame dimensions (from 2000)
- Up to width

Special equipment

Ventilation

- Ventilation slots in bottom seal
ventilation cross section 65 cm² for one metre door width
- Ventilation grille, ventilation cross section 40 cm² each
- Aluminium frame with expanded mesh
58 % ventilation cross section

Glazing options

- Aluminium frame (standard profile NF or thermal break profile WF)
- Glazing type D, 16 mm
- Panel glazing type S, 22 mm (see page 21)

Sectional Door LPU 40

Double-skinned steel sections, fitting in front of the reveal

M-ribbed

Micrograin

External views

(The illustrations correspond to size 2500 × 2125 mm. Deviations may occur with other door sizes.)

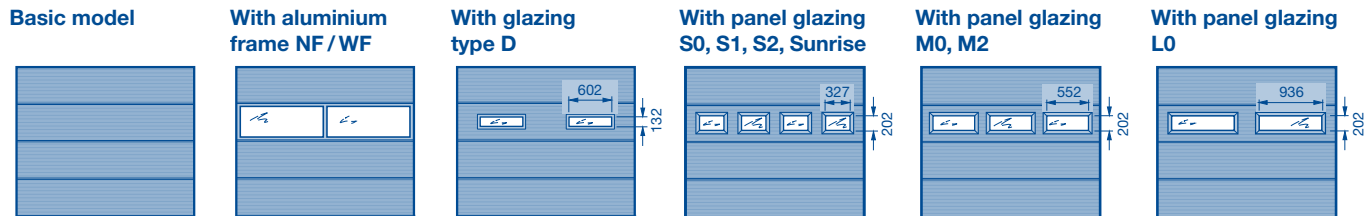

Size range

Door width in 5 mm increments, door height in grid height. Intermediate heights are possible.

												A	B	C			
RM	2205											4	550	275			
	2125											4	531	265			
	2080											4	520	260			
	2000											4	500	250			
	1955											4	488	244			
	1875											4	468	234			
			4		6								No. of ventilation grilles with 40 cm ² ventilation cross section each				
		2		3								No. of glazings – aluminium frame and type D					
	3 → 2125	4			5									No. of glazings – type S			
	2 → 2240	3											No. of glazings – type M				
		2											No. of glazings – type L				
		2250	2375	2500	2750	3000	3250	3500	3750	4000	4250	4500	4750	5000	LZ		

- A No. of door sections
- B Door section height
- C Spacing
- RM Grid height

- LZ Clear frame dimensions (from 2000)
- Up to width

Special equipment

Ventilation

- Ventilation slots in bottom seal
ventilation cross section 65 cm² for one metre door width
- Ventilation grille, ventilation cross section 40 cm² each
- Aluminium frame with expanded mesh
58 % ventilation cross section

Glazing options

- Aluminium frame (standard profile NF or thermal break profile WF)
- Glazing type D, 16 mm
- Panel glazing type S, 22 mm (see page 21)

Sectional Door LPU 40

Double-skinned steel sections, fitting in front of the reveal

L-ribbed

Woodgrain

External views

(The illustrations correspond to size 2500 × 2125 mm. Deviations may occur with other door sizes.)

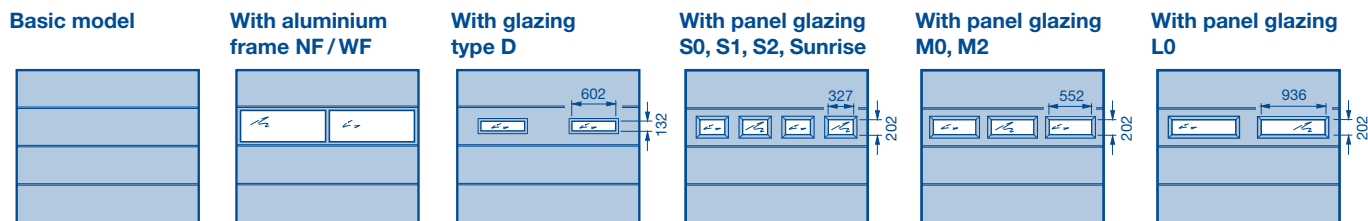

Size range

Door width in 5 mm increments, door height in grid height. Intermediate heights are possible.

												A	B			
RM	2205											4	550			
	2125											4	531			
	2080											4	520			
	2000											4	500			
	1955											4	488			
	1875											4	468			
		4	6											No. of ventilation grilles with 40 cm ² ventilation cross section each		
		2	3											No. of glazings – aluminium frame and type D		
3 → 2125		4	5											No. of glazings – type S		
2 → 2240		3												No. of glazings – type M		
		2												No. of glazings – type L		
		2250	2375	2500	2750	3000	3250	3500	3750	4000	4250	4500	4750	5000	LZ	

A No. of door sections
 B Door section height
 RM Grid height

LZ Clear frame dimensions (from 2000)
 → Up to width

Special equipment

Ventilation

- Ventilation slots in bottom seal ventilation cross section 65 cm² for one metre door width
- Ventilation grille, ventilation cross section 40 cm² each
- Aluminium frame with expanded mesh 58 % ventilation cross section

Glazing options

- Aluminium frame (standard profile NF or thermal break profile WF)
- Glazing type D, 16 mm
- Panel glazing type S, 22 mm (see page 21)

Sectional Door LPU 40

Double-skinned steel sections, fitting in front of the reveal

L-ribbed

Silkgrain

External views

(The illustrations correspond to size 2500 × 2125 mm. Deviations may occur with other door sizes.)

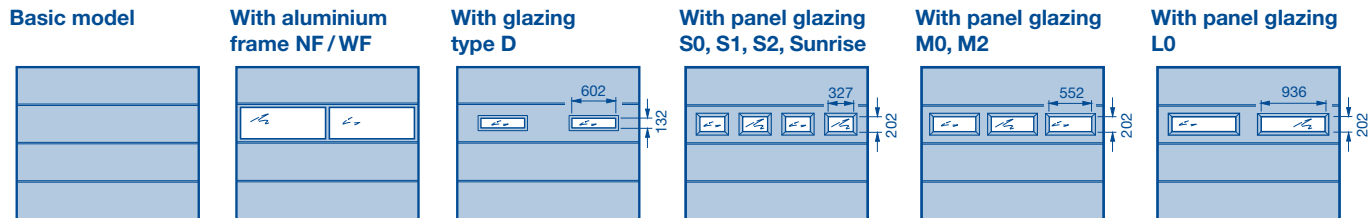

Size range

Door width in 5 mm increments, door height in grid height. Intermediate heights are possible.

														A	B		
RM	2205													4	550		
	2125													4	531		
	2080													4	520		
	2000													4	500		
	1955													4	488		
	1875													4	468		
		4	6													No. of ventilation grilles with 40 cm ² ventilation cross section each	
		2	3													No. of glazings – aluminium frame and type D	
3 → 2125		4	5													No. of glazings – type S	
2 → 2240		3														No. of glazings – type M	
		2														No. of glazings – type L	
		2250	2375	2500	2750	3000	3250	3500	3750	4000	4250	4500	4750	5000	LZ		

A No. of door sections

B Door section height

RM Grid height

LZ Clear frame dimensions (from 2000)

→ Up to width

Special equipment

Ventilation

- Ventilation slots in bottom seal ventilation cross section 65 cm² for one metre door width
- Ventilation grille, ventilation cross section 40 cm² each
- Aluminium frame with expanded mesh 58 % ventilation cross section

Glazing options

- Aluminium frame (standard profile NF or thermal break profile WF)
- Glazing type D, 16 mm
- Panel glazing type S, 22 mm (see page 21)

Sectional Door LPU 40

Double-skinned steel sections, fitting in front of the reveal

L-ribbed

Micrograin

External views

(The illustrations correspond to size 2500 × 2125 mm. Deviations may occur with other door sizes.)

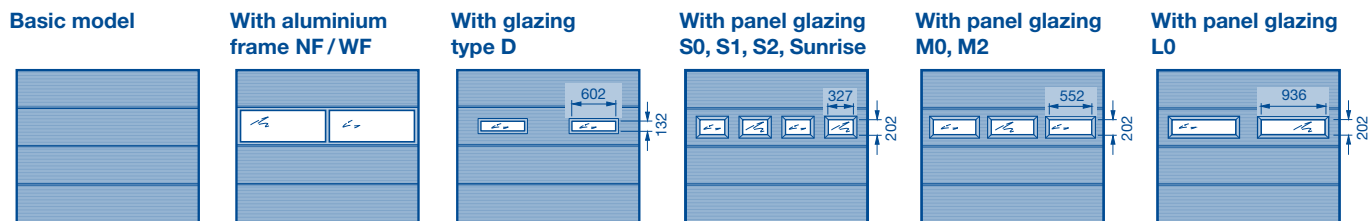

Size range

Door width in 5 mm increments, door height in grid height. Intermediate heights are possible.

														A	B	
RM	2205													4	550	
	2125													4	531	
	2080													4	520	
	2000													4	500	
	1955													4	488	
	1875													4	468	
		4	6											No. of ventilation grilles with 40 cm ² ventilation cross section each		
		2	3											No. of glazings – aluminium frame and type D		
3 → 2125		4	5											No. of glazings – type S		
2 → 2240		3												No. of glazings – type M		
		2												No. of glazings – type L		
		2250	2375	2500	2750	3000	3250	3500	3750	4000	4250	4500	4750	5000	LZ	

A No. of door sections
B Door section height
RM Grid height

LZ Clear frame dimensions (from 2000)
 → Up to width

Special equipment

Ventilation

- Ventilation slots in bottom seal ventilation cross section 65 cm² for one metre door width
- Ventilation grille, ventilation cross section 40 cm² each
- Aluminium frame with expanded mesh 58 % ventilation cross section

Glazing options

- Aluminium frame (standard profile NF or thermal break profile WF)
- Glazing type D, 16 mm
- Panel glazing type S, 22 mm (see page 21)

Track Applications: Z, N

Z: Tension spring track application

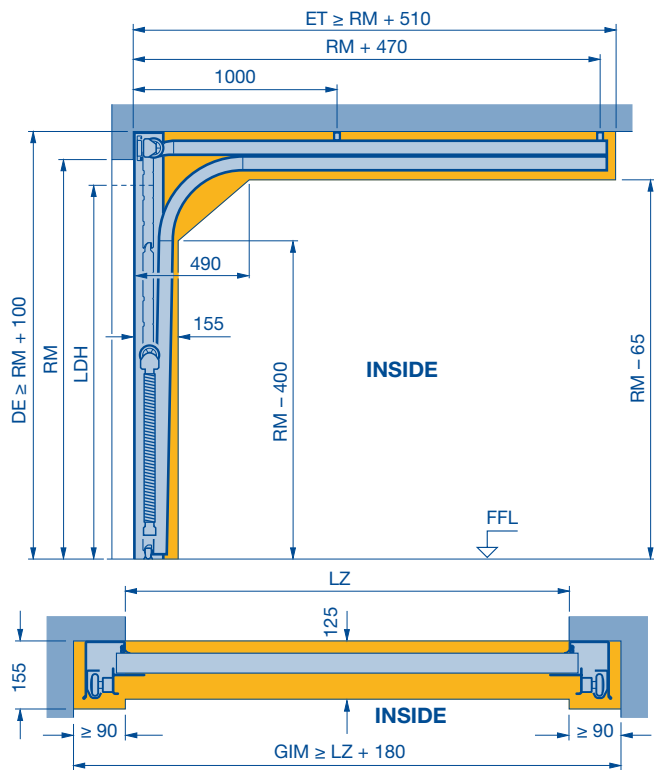

RM Height	Manual operation		With operator		
	Min. DE	LDH	Min. DE	Min. DE with Thermo Frame	LDH
	RM + 100	RM - 80	RM + 115	RM + 145	RM - 30
1875	1975	1795	1990	2020	1845
1955	2055	1875	2070	2100	1925
2000	2100	1920	2115	2145	1970
2080	2180	2000	2195	2225	2050
2125	2225	2045	2240	2270	2095
2205	2305	2125	2320	2350	2175
2250	2350	2170	2365	2395	2220
2375	2475	2295	2490	2520	2345
2500	2600	2420	2615	2645	2470
2625	2725	2545	2740	2765	2595

- LDH** Clear passage height
- RM** Grid height
- LZ** Clear frame dimensions
- DE** Ceiling height
- ET** Distance back
- GIM** Inside garage dimension

Note:

The clearance for fitting and subsequent operation of the door must be complied with.

N: Normal track application

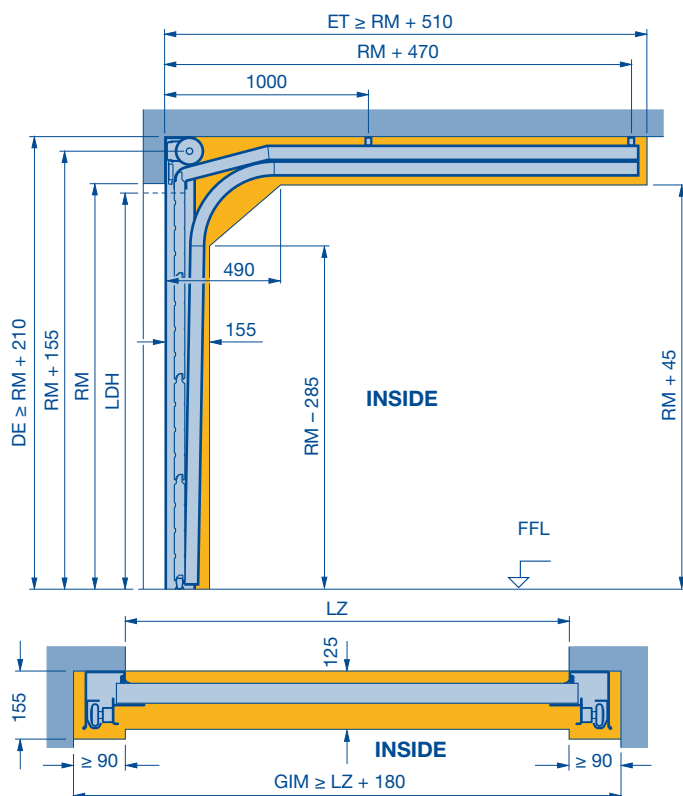

RM Height	Manual operation		With operator		
	Min. DE	LDH	Min. DE	Min. DE with Thermo Frame	LDH
	RM + 210	RM - 50	RM + 210	RM + 255	RM
1875	2085	1825	2085	2130	1875
1955	2165	1905	2165	2210	1955
2000	2210	1950	2210	2255	2000
2080	2290	2030	2290	2335	2080
2125	2335	2075	2335	2380	2125
2205	2415	2155	2415	2460	2205
2250	2460	2200	2460	2505	2250
2375	2585	2325	2585	2630	2375
2500	2710	2450	2710	2755	2500
2625	2835	2575	2835	2880	2625
2750	2960	2700	2960	3005	2750
2875	3085	2825	3085	3130	2875
3000	3210	2950	3210	3255	3000

- LDH** Clear passage height
- RM** Grid height
- LZ** Clear frame dimensions
- DE** Ceiling height
- ET** Distance back
- GIM** Inside garage dimension

Note:

The clearance for fitting and subsequent operation of the door must be complied with.

Track Applications: L, H

L: Low headroom track application

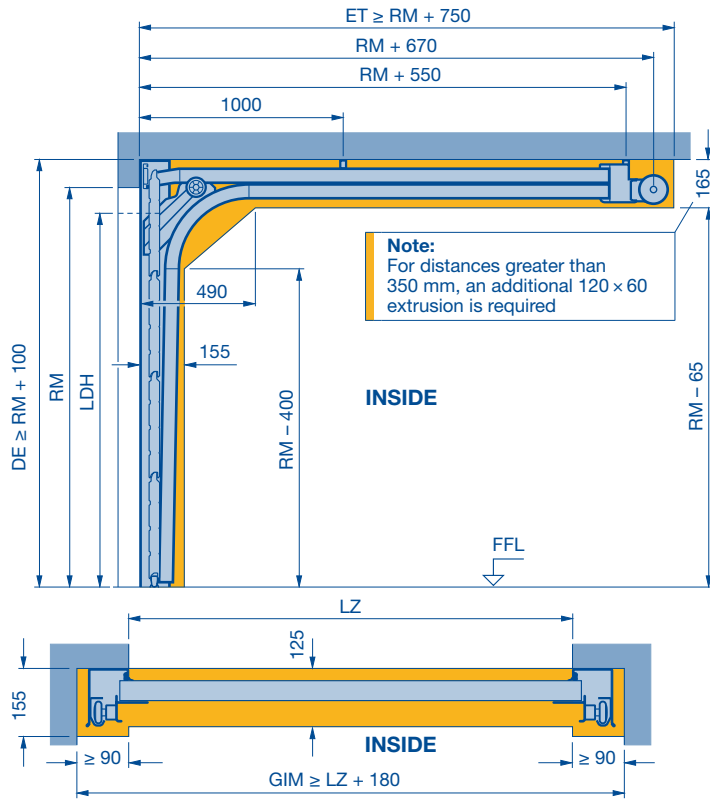

RM Height	Manual operation		With operator			
	Min. DE	LDH	Min. DE	Min. DE with Thermo Frame	LDH Up to LZ = 3000 mm	LDH From LZ = 3010 mm
	RM + 100	RM - 100	RM + 115	RM + 145	RM - 30	RM - 80
1875	1975	1775	1990	2020	1845	1795
1955	2055	1855	2070	2100	1925	1875
2000	2100	1900	2115	2145	1970	1920
2080	2180	1980	2195	2225	2050	2000
2125	2225	2025	2240	2270	2095	2045
2205	2305	2105	2320	2350	2175	2125
2250	2350	2150	2365	2395	2220	2170
2375	2475	2275	2490	2520	2345	2295
2500	2600	2400	2615	2645	2470	2420
2625	2725	2525	2740	2790	2595	2545
2750	2850	2650	2865	2895	2720	2670
2875	2975	2775	2990	3020	2845	2795
3000	3100	2900	3115	3145	2970	2920

LDH Clear passage height
 RM Grid height
 LZ Clear frame dimensions
 DE Ceiling height

ET Distance back
 GIM Inside garage dimension

Note:
 The clearance for fitting and subsequent operation of the door must be complied with.

H: High-lift track application

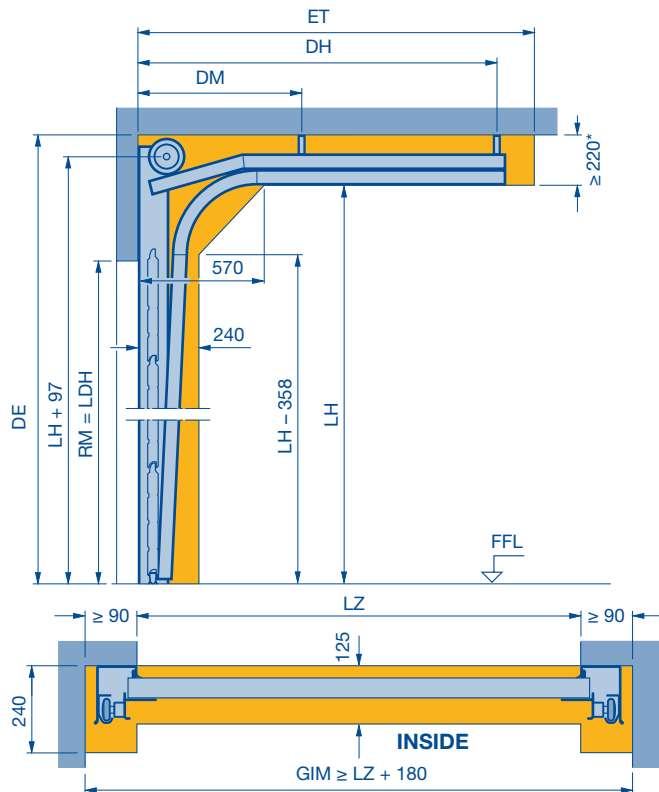

Not for EPU 40 or versions with wicket door.
 For LTH 40 doors, a SupraMatic operator is required!

Door height RM Height	Track height			
	(1) with spring buffer		(2) with buffer stop	
	Min.	Max.	Min.	Max.
1875	2260	2634	2635	3190
1955	2340	2714	2715	3270
2000	2385	2759	2760	3315
2080	2465	2839	2840	3395
2125	2510	2884	2885	3440
2205	2590	2964	2965	3520
2250	2635	3009	3010	3565
2375	2760	3134	3135	3690
2500	2885	3259	3260	3815
2625	3010	3384	3385	3940
2750	3135	3509	3510	4065
2875	3315	3634	3635	4190
3000	3565	3759	3760	4315

LDH Clear passage height
 RM Grid height
 LF Structural opening
 LH Track height
 LZ Clear frame dimensions
 DE Ceiling height
 DH Rear ceiling anchor = ET - 200
 DM Centre ceiling anchor = DH / 2

ET Distance back
 (1) = 2 x RM + 690 - LH
 (2) = 2 x RM + 490 - LH
 GIM Minimum inside garage dimension
 * with ThermoFrame \geq 255

Note:
 The clearance for fitting and subsequent operation of the door must be complied with.

Track Application: N

(LPU 40) Wicket door

N: Normal track application

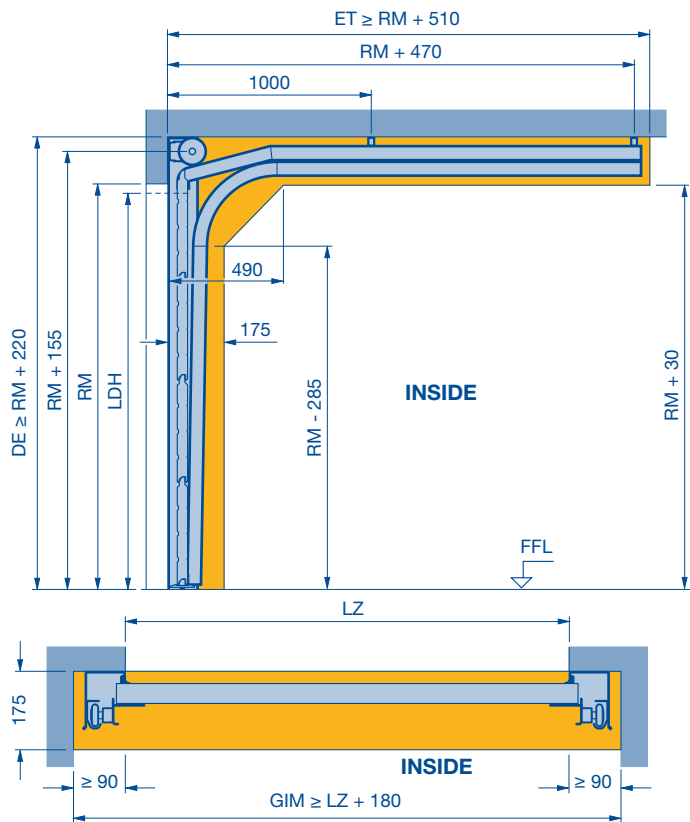

RM Height	Manual operation		With operator		
	Min. DE	LDH	Min. DE	Min. DE with Thermo Frame	LDH
	RM + 220	RM - 160	RM + 235	RM + 255	RM - 100
1875	2095	1715	2110	2130	1775
1955	2175	1795	2190	2210	1855
2000	2220	1840	2235	2255	1900
2080	2300	1920	2315	2335	1980
2125	2345	1965	2360	2380	2025
2205	2425	2045	2440	2460	2105
2250	2470	2090	2485	2505	2150
2375	2595	2215	2610	2630	2275
2500	2720	2340	2735	2755	2400
2625	2845	2465	2860	2880	2525
2750	2970	2590	2985	3005	2650
2875	3095	2715	3110	3130	2775
3000	3220	2840	3235	3255	2900

- LDH** Clear passage height
- RM** Grid height
- LZ** Clear frame dimensions
- DE** Ceiling height
- ET** Distance back
- GIM** Inside garage dimension

Note:

The clearance for fitting and subsequent operation of the door must be complied with.

Note:

Due to the low threshold height, the ground in front of the garage must be level or sloped to guarantee smooth opening of the wicket door (opening outwards) – see page 47.

Note:

For doors up to RM 2250 in S-panelled versions or in S, M or L-ribbed versions and top glazing type D, S and M, the distance from FFL to the bottom edge of the lintel must be equal to or greater than the ordering size (RM).
Deviating sizes on request!

Track Application: L

(LPU 40) Wicket door

L: Low headroom track application

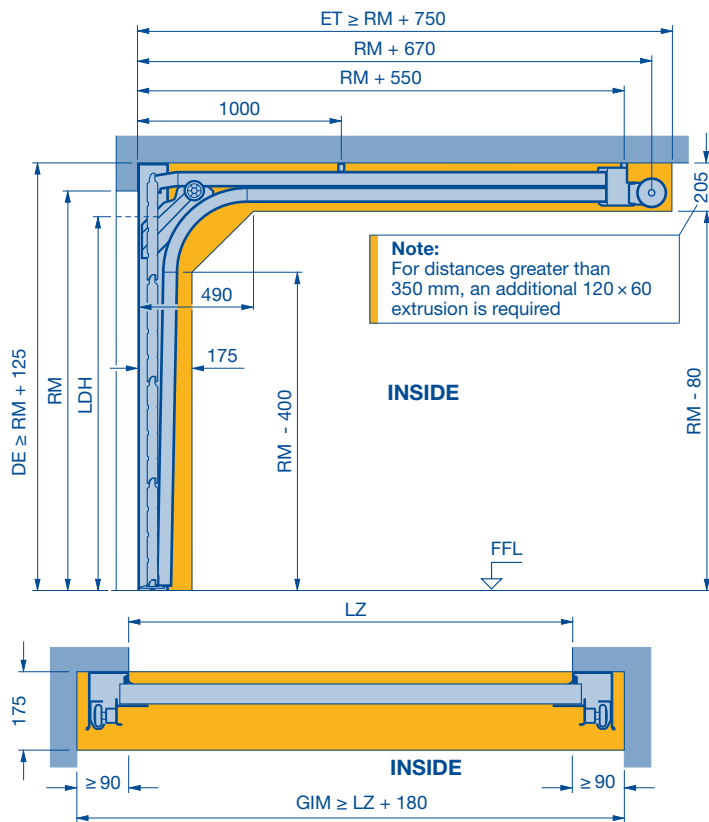

RM Height	Manual operation		With operator		
	Min. DE	LDH	Min. DE	Min. DE with Thermo Frame	LDH
	RM + 125	RM - 160	RM + 125	RM + 145	RM - 160
1875*	2000	1715	2000	2020	1715
1955	2080	1795	2080	2100	1795
2000	2125	1840	2125	2145	1840
2080	2205	1920	2205	2225	1920
2125	2250	1965	2250	2270	1965
2205	2330	2045	2330	2350	2045
2250	2375	2090	2375	2395	2090
2375	2500	2215	2500	2520	2215
2500	2625	2340	2625	2645	2340
2625	2750	2465	2750	2770	2465
2750	2875	2590	2875	2895	2590
2875	3000	2715	3000	3020	2715
3000	3125	2840	3125	3145	2840

* These versions are only available for S/M/L-ribbed doors

- LDH** Clear passage height
- RM** Grid height
- LZ** Clear frame dimensions
- DE** Ceiling height
- ET** Distance back
- GIM** Inside garage dimension

Note:

The clearance for fitting and subsequent operation of the door must be complied with.

Note:

Due to the low threshold height, the ground in front of the garage must be level or sloped to guarantee smooth opening of the wicket door (opening outwards) – see page 47.

Note:

For doors up to RM 2250 in S-panelled versions or in S, M or L-ribbed versions and top glazing type D, S and M, the distance from FFL to the bottom edge of the lintel must be equal to or greater than the ordering size (RM).
Deviating sizes on request!

Track Applications: BZ, BL

BZ: track application Z / track application for flush-fitting panel

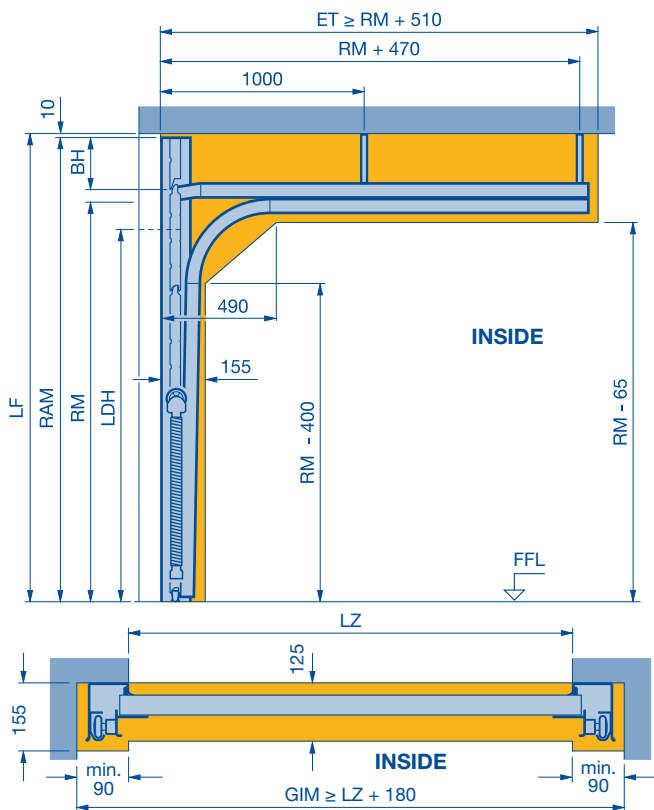

RM Height	RAM		Manual operation	With operator
	Min. RM + 240	Max.	LDH RM - 80	LDH RM - 30
1875	2115	2379	1795	1845
1955	2195	2479	1875	1925
2000	2240	2539	1920	1970
2080	2320	2639	2000	2050
2125	2365	2694	2045	2095
2205	2445	2789	2125	2175
2250	2490	2849	2170	2220
2375	2615	2889	2295	2345
2500	2740	3039	2420	2470
2625	2865	3189	2545	2595

- LDH** Clear passage height
- RM** Grid height
- LZ** Clear frame dimensions
- DE** Ceiling height
- ET** Min. distance back = RM + 440
- GIM** Inside garage dimension
- BH** Fascia height
- RAM** Overall frame dimension = ordering size
Min. RAM = RM + 240
Max. RAM = 3189
- LF** Structural opening

Note:
The clearance for fitting and subsequent operation of the door must be complied with.

Note:
Shortened top door section or top aluminium frame is not possible.

BL: track application L / track application for flush-fitting panel

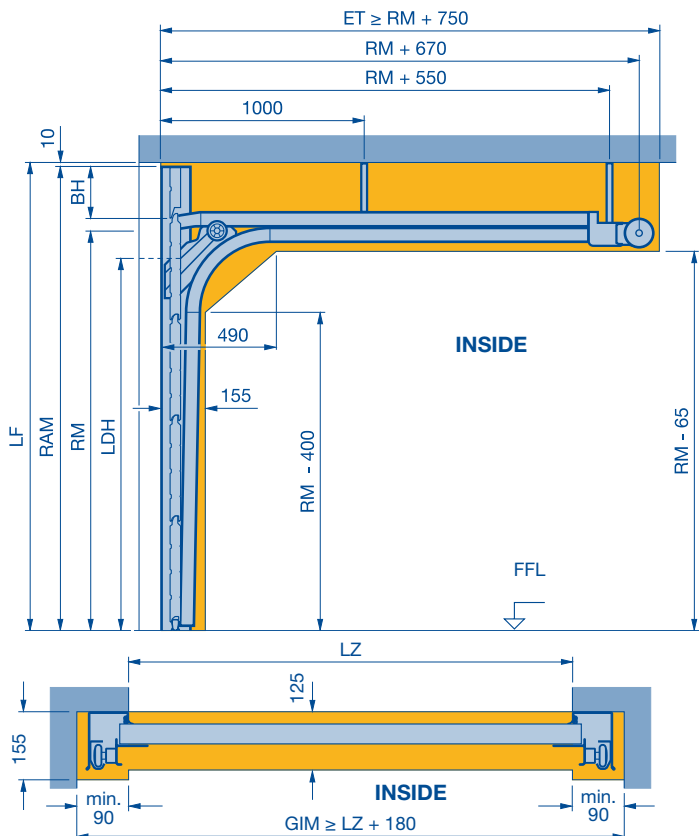

RM Height	RAM		Manual operation	With operator	
	Min. RM + 240	Max.	LDH RM - 100	LDH up to LZ ≤ 3000 RM - 30	LDH from LZ ≥ 3010 RM - 80
1875	2115	2379	1775	1845	1795
1955	2195	2479	1855	1925	1875
2000	2240	2539	1900	1970	1920
2080	2320	2639	1980	2050	2000
2125	2365	2694	2025	2095	2045
2205	2445	2789	2105	2175	2125
2250	2490	2849	2150	2220	2170
2375	2615	2889	2275	2345	2295
2500	2740	3039	2400	2470	2420
2625	2865	3189	2525	2595	2545
2750	2990	3339	2650	2720	2670
2875	3115	3392	2775	2845	2795
3000	3240	3539	2900	2970	2920

- LDH** Clear passage height
- RM** Grid height
- LZ** Clear frame dimensions
- DE** Ceiling height
- ET** Distance back
- GIM** Inside garage dimension
- BH** Fascia height
- RAM** Overall frame dimension = ordering size
Min. RAM = RM + 240
Max. RAM = 3539
- LF** Structural opening

Note:
The clearance for fitting and subsequent operation of the door must be complied with.

Note:
Shortened top door section or top aluminium frame is not possible.

Track Applications: BL

(LPU 40) Wicket door

BL: track application L / track application for flush-fitting panel

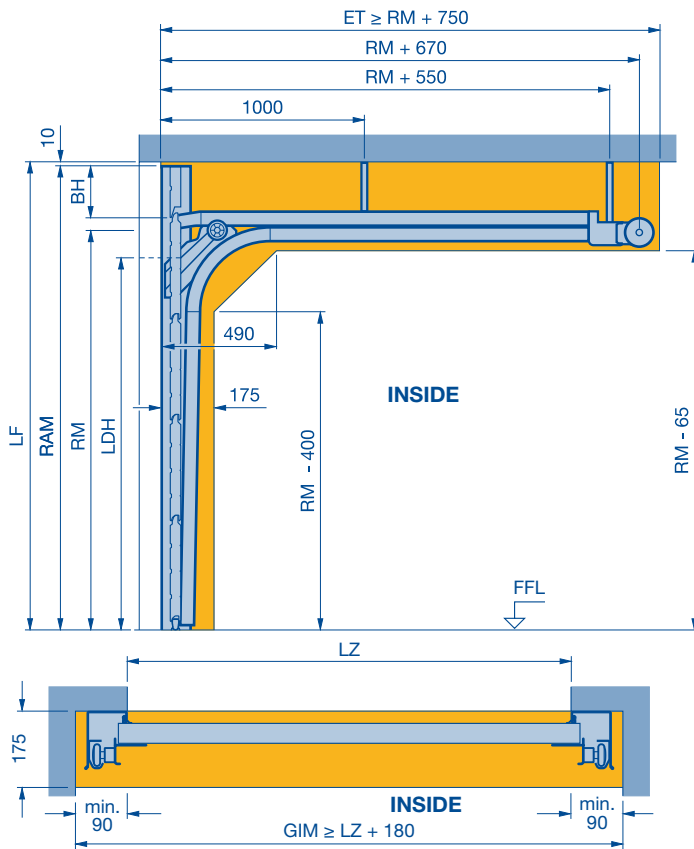

RM Height	RAM		Manual operation	With operator
	Min. RM + 240	Max.	LDH RM - 160	LDH RM - 160
1875	2115	2379	1715	1715
1955	2195	2479	1795	1795
2000	2240	2539	1840	1840
2080	2320	2639	1920	1920
2125	2365	2694	1965	1965
2205	2445	2789	2045	2045
2250	2490	2849	2090	2090
2375	2615	2889	2215	2215
2500	2740	3039	2340	2340
2625	2865	3189	2465	2465
2750	2990	3339	2590	2590
2875	3115	3392	2715	2715
3000	3240	3539	2840	2840

- LDH** Clear passage height
- RM** Grid height
- LZ** Clear frame dimensions
- DE** Ceiling height
- ET** Distance back
- GIM** Inside garage dimension
- BH** Fascia height
- RAM** Overall frame dimension = ordering size
Min. RAM = RM + 240
Max. RAM = 3539
- LF** Structural opening

Note:

The clearance for fitting and subsequent operation of the door must be complied with.

Note:

Due to the low threshold height, the ground in front of the garage must be level or sloped to guarantee smooth opening of the wicket door (opening outwards) – see page 47.

Note:

Shortened top door section or top aluminium frame is not possible.

Clearance for lintel fitting with flush-fitting panel

Without lintel

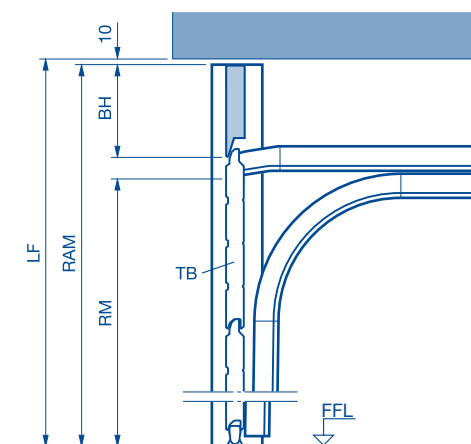

With lintel

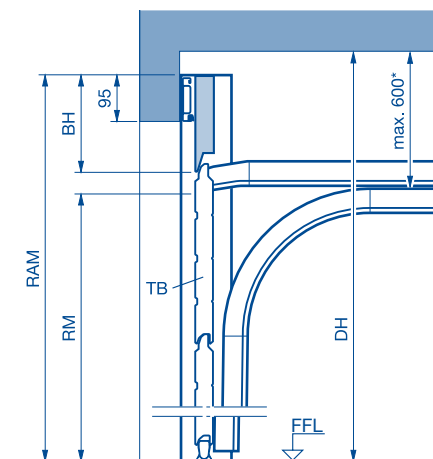

Track application	Panel version
BZ and BL	PU fascia, S, M and L-ribbed S-panelled on request

- DH** Ceiling height
- TB** Door leaf
- * Suspension = DH - RM = max. 600 mm

Track Application: Z

Fitting in front of the reveal

Z: Tension spring track application

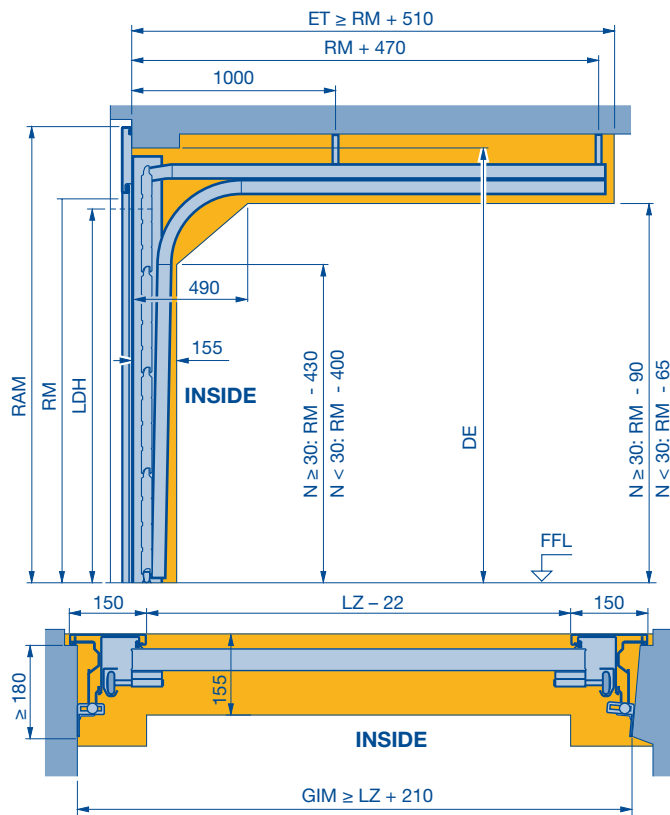

RM Height	N ≥ 30			
	Manual operation		With operator	
	Min. DE	LDH	Min. DE	LDH
1875	RM + 75	RM - 110	RM + 90	RM - 60
1955	1950	1765	1965	1815
2000	2030	1845	2045	1895
2080	2075	1890	2090	1940
2125	2155	1970	2170	2020
2205	2200	2015	2215	2065
	2280	2095	2295	2145

RM Height	N < 30			
	Manual operation		With operator	
	Min. DE	LDH	Min. DE	LDH
1875	RM + 100	RM - 80	RM + 115	RM - 30
1955	1975	1795	1990	1845
2000	2055	1875	2070	1925
2080	2100	1920	2115	1970
2125	2180	2000	2195	2050
2205	2225	2045	2240	2095
	2305	2125	2320	2175

- LDH** Clear passage height
 - RM** Grid height
 - LZ** Clear frame dimensions
 - DE** Ceiling height
 - ET** Distance back
 - GIM** Inside garage dimension
 - n** Height difference between interior and exterior garage floor
 - RAM** Overall frame dimension
- RAM height** Min. = $RM + 115$ mm
Mx. = $RM + 185$ mm

Examples for fitting situation

With $N \geq 30$ mm **With $N < 30$ mm**
 $LDH = RM - 110$ mm without operator $LDH = RM - 80$ mm without operator

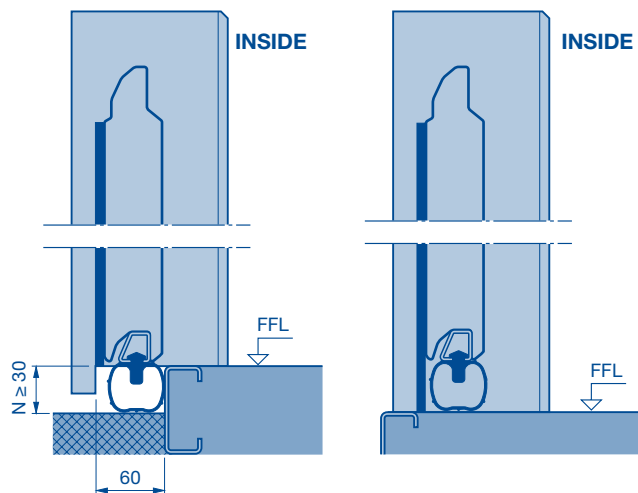

Distance back without operator:
 $RM + 510$ mm

Distance back with operator ProMatic and SupraMatic:
 3200 mm with door height up to 2125 mm (K-boom)
 3450 mm with door height up to 2375 mm (M-boom)

Note:
 The clearance for fitting and subsequent operation of the door must be complied with.

Sideroom

Track applications Z, N, L, H

Normal track application, **sideroom 90 mm**, fixing inside the frame

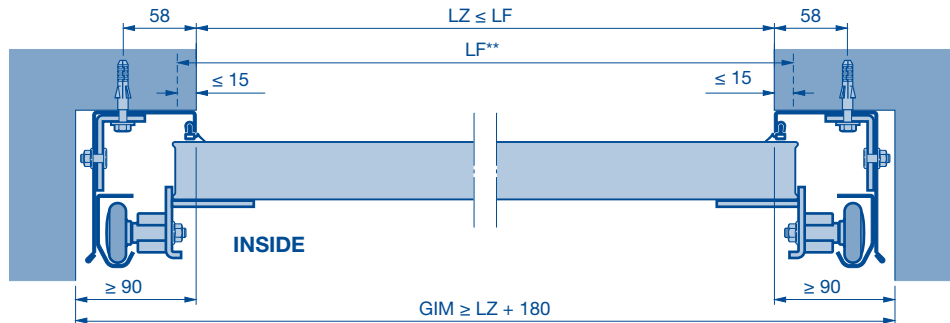

Sideroom less than 75 mm, or without sideroom. Frame fixing using special anchor

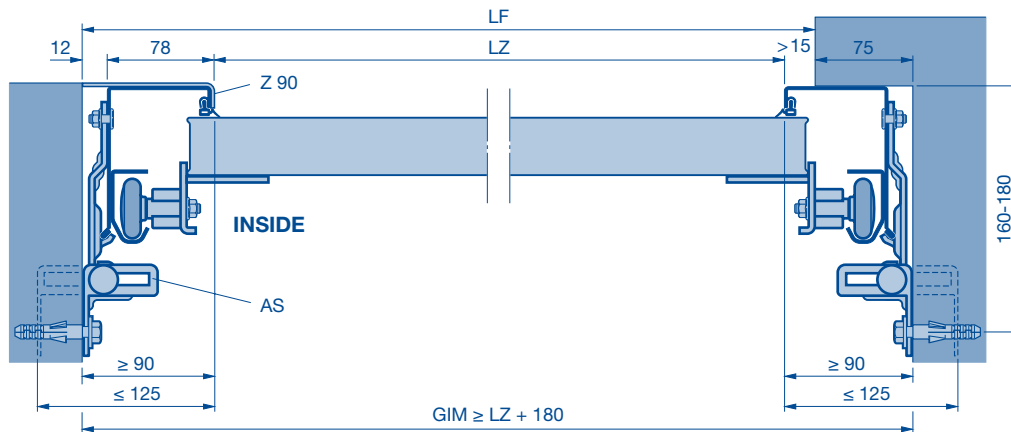

Min. sideroom 75 mm, fixing outside the frame

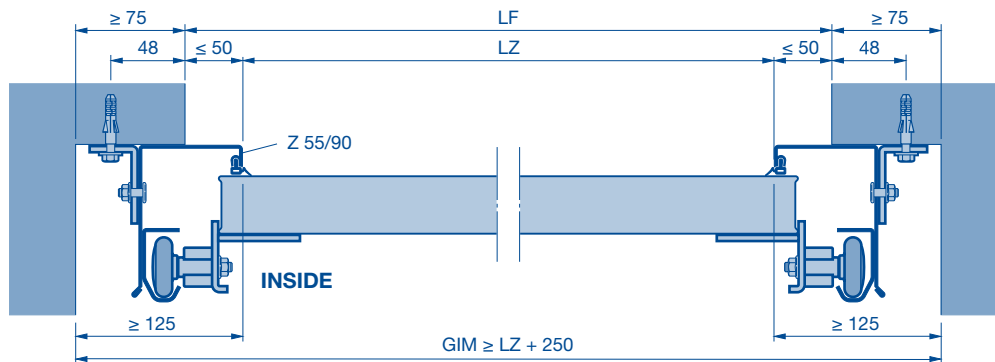

Frame fixing to tube with fixed element using special anchor

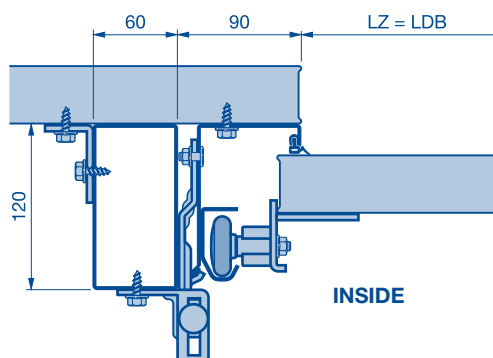

Frame fixing when using a thermal insulation composite system

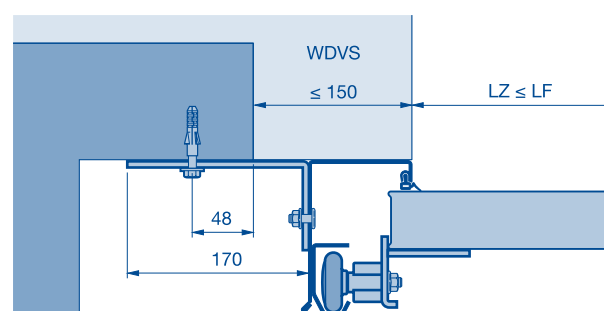

(See next page for the legend)

Sideroom and Lintel Fitting with ThermoFrame

Track applications Z, N, L, H with ThermoFrame

Normal track application, sideroom 90 mm, fixing inside the frame

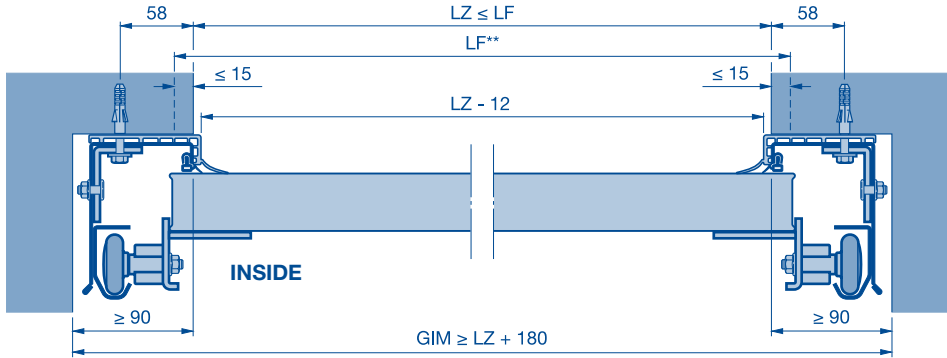

Sideroom less than 75 mm, or without sideroom. Frame fixing using special anchor

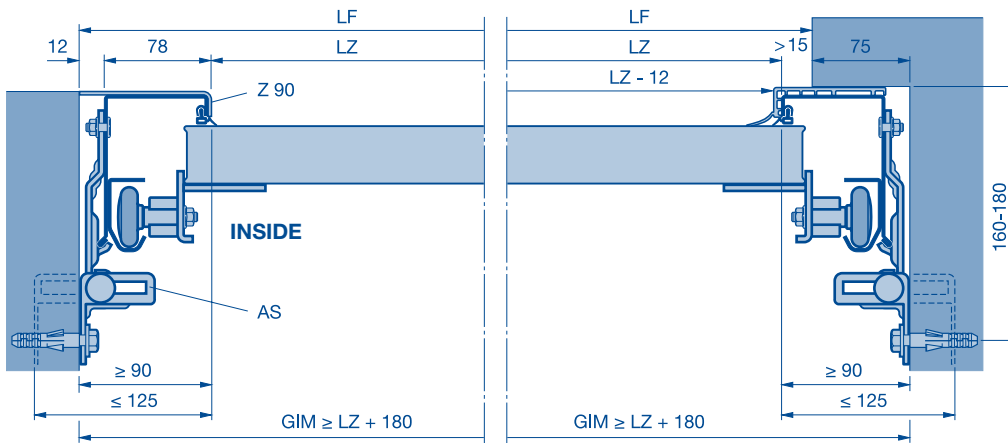

Lintel fitting with ThermoFrame

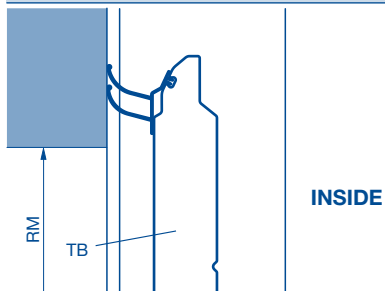

*	Min.
**	Max.
LZ	Clear frame dimensions
LF	Structural opening
GIM	Inside garage dimension
Z 55	Frame covering 55

Z 90	Frame covering 90
AS	Special anchor
RAMB	Overall frame dimension width
TB	Door leaf
WDVS	Thermal insulation composite system

Sideroom

Fitting in front of the reveal

Fitting in front of the reveal

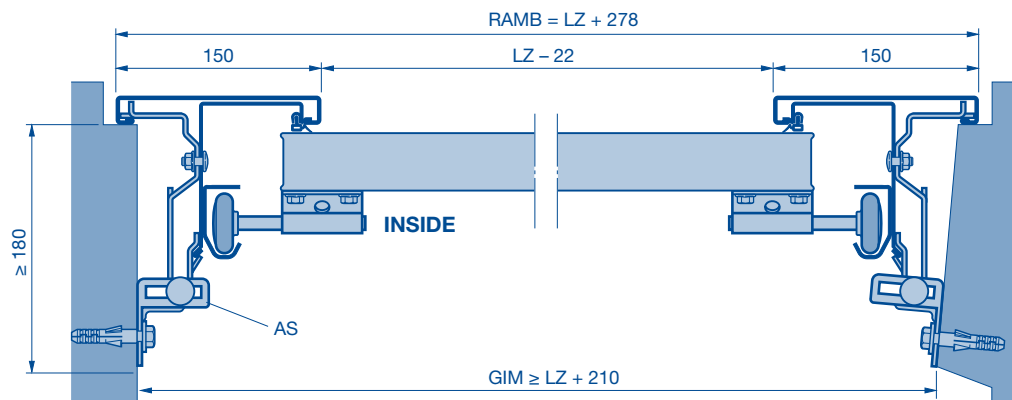

Fitting in the opening

Fascia frame -95-

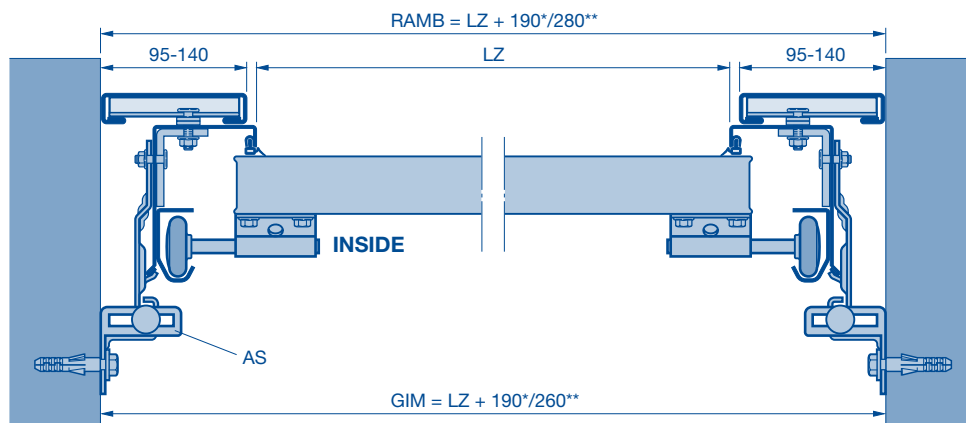

Fitting behind the opening

Retrofit fascia

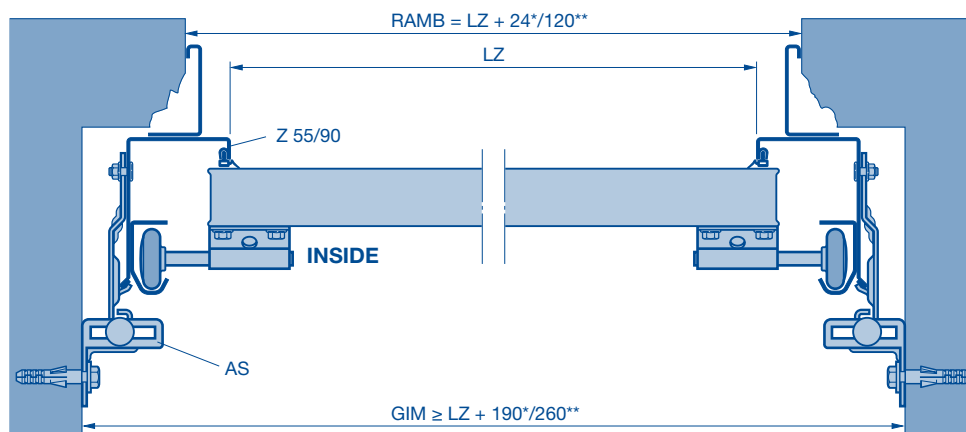

*	Min.	Z 90	Frame covering 90
**	Max.	AS	Special anchor
LZ	Clear frame dimensions	RAMB	Overall frame dimension width
LF	Structural opening	TB	Door leaf
GIM	Inside garage dimension		
Z 55	Frame covering 55		

Lintel Fitting with Fascia Panels

LTE 40, EPU 40, LPU 40

View A

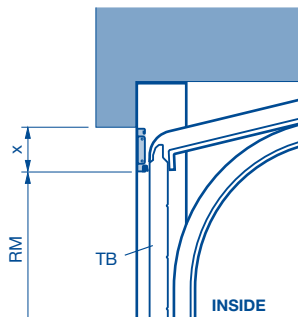

View B

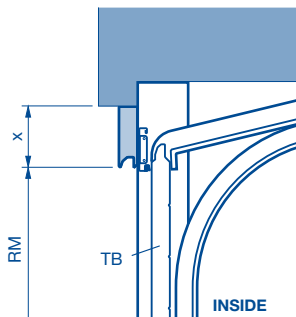

View C

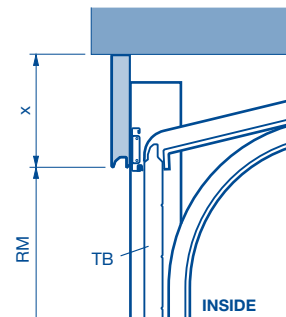

Track application	Panel version	Dimension x		
		View A	View B	View C
Z, N and L	Steel fascia (in scope of delivery)	Up to 100 mm	-	-
	PU panel, S/L-ribbed	-	61 – 562 mm	61 – 562 mm
	PU panel, M-ribbed	-	250 – 562 mm	250 – 562 mm
	PU fascia, S-panelled	-	-	468, 475, 479, 488, 500, 520, 525, 531, 550, 562

LTH 40 (A steel fascia is included in the scope of delivery for LTH 40 doors!)

View A

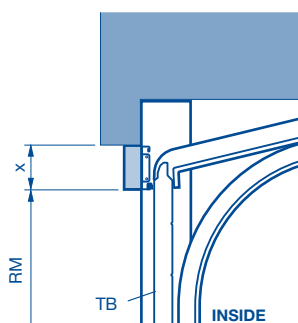

View B

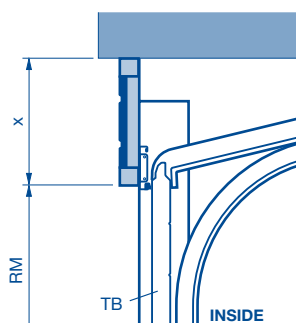

View C

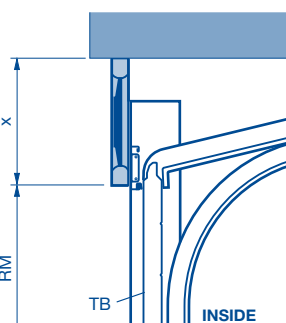

Track application	Panel version	Dimension x		
		View A	View B	View C
N and L	Smooth timber panel	31 – 290 mm	-	-
	Timber panel, S-ribbed	-	146 – 562 mm	-
	Timber panel, V-panelled	-	-	291 – 562 mm

LTE 40, LPU 40

Retrofit fascias

Fascia frame -95-

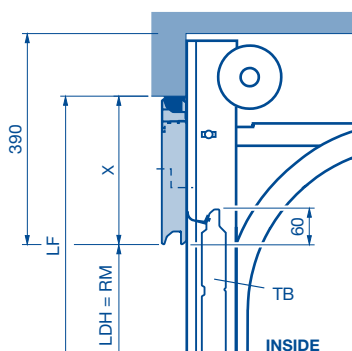

Angle section

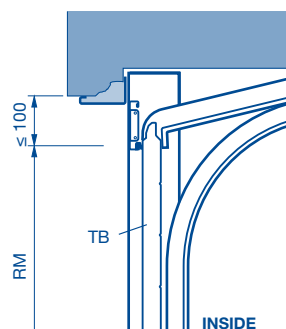
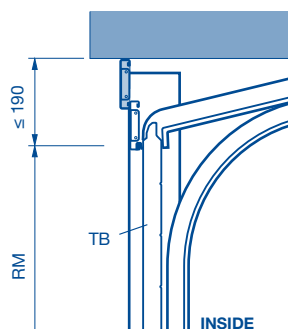

Track applications N, ND, L as industry version (galvanized frame)	Dimension x
PU fascia, S/L-ribbed	100 – 562 mm
PU panel, M-ribbed	250 – 562 mm
PU fascia, S-panelled	468, 475, 479, 488, 500, 520, 525, 531, 550, 562

ATTENTION:

Observe the frame's plug and screw fitting points in the lintel area, since they are subject to an increased torque with track application N (torsion spring).

TB Door leaf
RM Grid height

LDH Clear passage height
LF Structural opening

Bottom Edge

Without wicket door

With wicket door

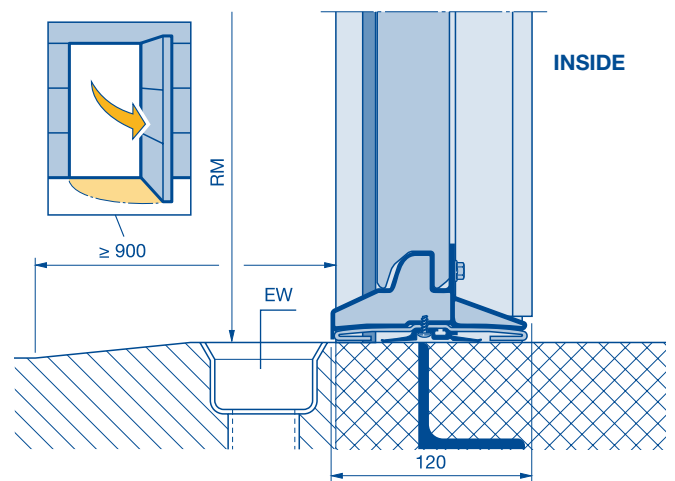
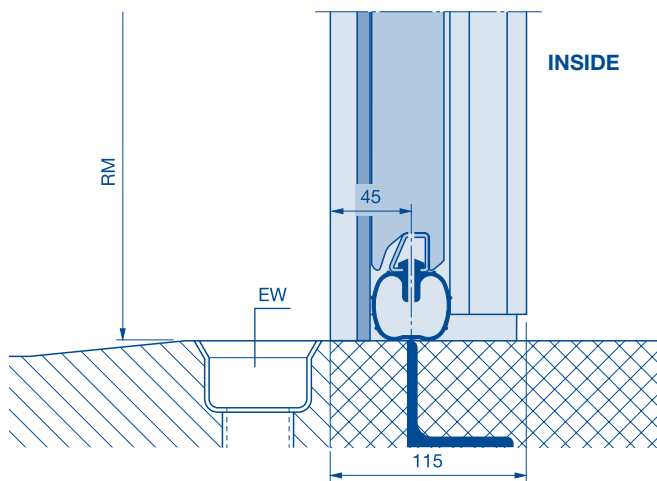
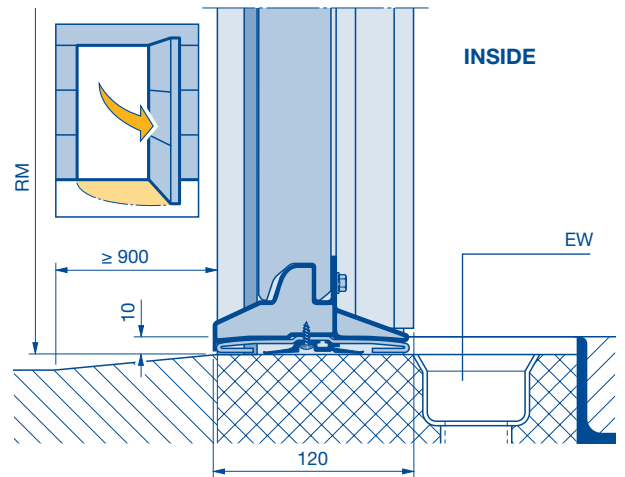
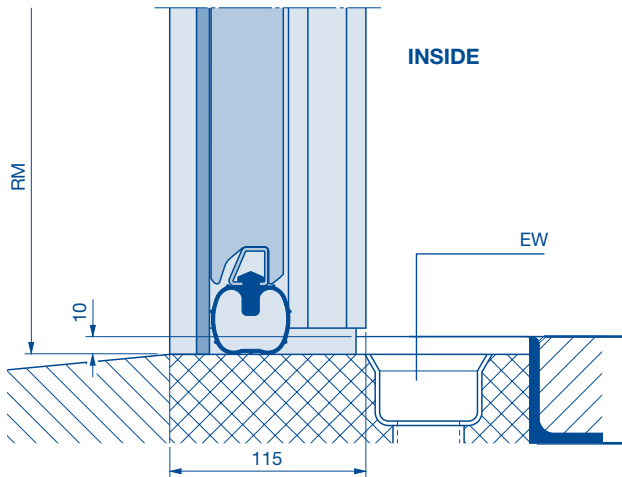
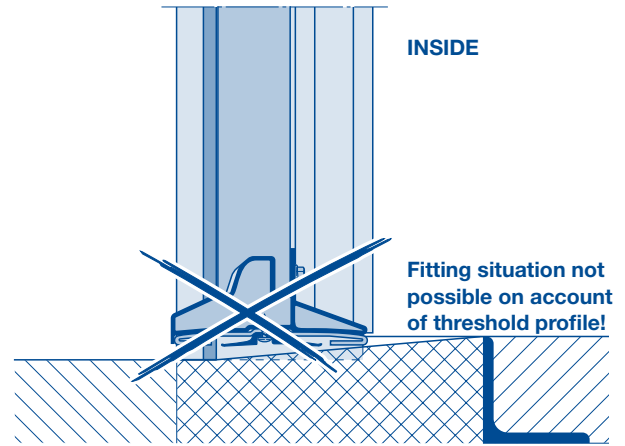
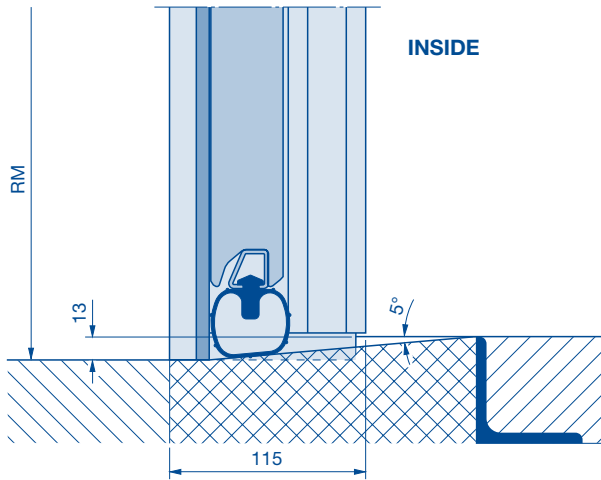

EW Drainage
RM Grid

Side Doors

With corner frame made of aluminium profiles

Standard / special sizes

External views

(The illustrations correspond to the size of the structural opening for 1000 × 2125 mm. Deviations may occur with other door sizes.)

* Side door version styles (see page 24) only possible with profile type 1

Profile type 1 and 3

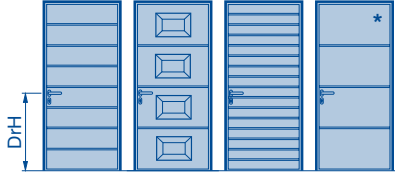

Profile type 2



Standard sizes

Profile type 1, only opening inwards, S, M, L-ribbed or S-panelled Fitting: internal fitting		
Ordering sizes = BRB	DRH from FFL	B
875 × 2000	955	500
875 × 2125	1010	531
1000 × 2000	955	500
1000 × 2125	1010	531

Profile type 2 S, M, L-ribbed Fitting: internal or external fitting		
Ordering sizes = BRB	DRH from FFL	B
875 × 2000	1050	500
875 × 2125	1050	531
1000 × 2000	1050	500
1000 × 2125	1050	531

Profile type 3 S, M, L-ribbed or S-panelled Fitting: external fitting		
Ordering sizes = BRB	DRH from FFL	B
875 × 2000	955	500
875 × 2125	1010	531
1000 × 2000	955	500
1000 × 2125	1010	531

Special sizes

Profile type 1 or 3 S-panelled or design element Fitting: internal fitting for profile type 1, external fitting for profile type 3	
Ordering sizes = BRB	DRH from FFL
875 – 1250 × 2000 or 2125	898 – 1064
875 – 1250 × 2000, 2080, 2125, 2205, 2250, 2375 or 2500	898 – 1064

Profile type 1, 2 or 3 S, M, L-ribbed Fitting: internal fitting for profile type 1, internal or external fitting for profile type 2, external fitting for profile type 3			
Ordering sizes = BRB	DRH from FFL		
	Profile type 1	Profile type 2	Profile type 3
875 – 1250 × 1875 – 2500	898 – 1064	1050	898 – 1064

Profile type 1 + 3	
B	DRH from FFL
468	898
475	911
479	917
488	934
500	955
520	990
525	1000
531	1010
550	1043
562	1064

Note with glazing type D:

Min. RAM width 980 mm and min. RAM height 2115 mm for glazing on the upper door section

Note:

3-point locking only possible with profile type 2.

(See next page for the legend)

Side Doors

With corner frame made of aluminium profiles

Standard / special sizes

Profile type 1
(only opening inwards)

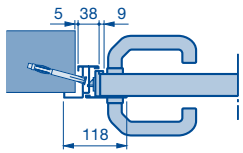

Profile type 2
(opening inwards)

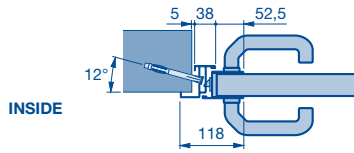

Profile type 2
(opening outwards)

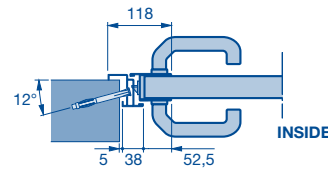

Profile type 3
(only opening outwards)

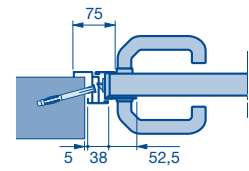

Internal fitting

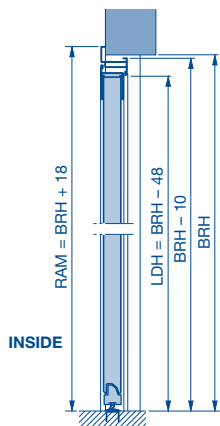

External fitting

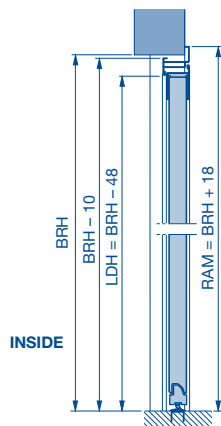

Internal fitting (opening inwards), profile type 1 or 2

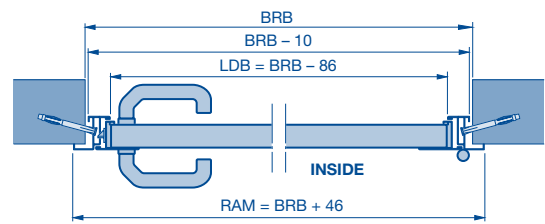
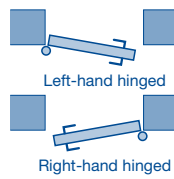

External fitting (opening outwards), profile type 2 or 3

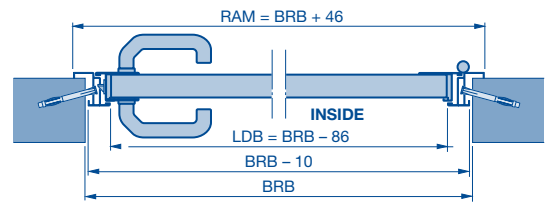
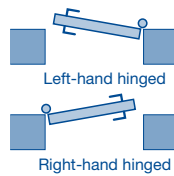

LF Structural opening
LDH Clear passage height
LDB Clear passage width
RM Grid height
RAM Overall frame dimension

B Door section height
BRH Nominal size
BRB Nominal size
DRH Lever height

Side Doors

With block frame made of aluminium profiles

Standard sizes

External views

(The illustrations correspond to the size of the structural opening for 1000 × 2125 mm. Deviations may occur with other door sizes.)

* Side door version styles (see page 24) only possible with profile type 1

Profile type 1

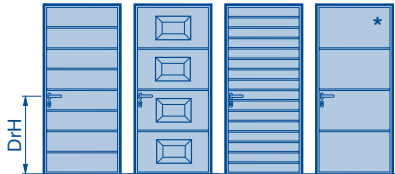

Profile type 2

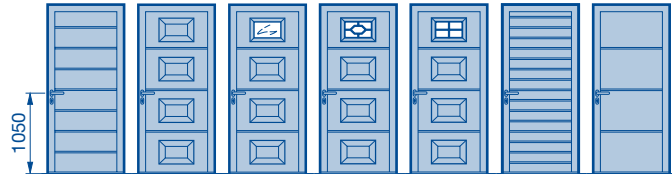

Standard sizes (profile type 1, only opening inwards)

Profile type 1 (fitting behind the opening) S, M, L-ribbed, S-panelled			
LF of the opening	Ordering sizes = RAM	DRH from FFL	B
855–875 × 1990–2000	990 × 2058	955	500
855–875 × 2115–2125	990 × 2183	1010	531
980–1000 × 1990–2000	1115 × 2058	955	500
980–1000 × 2115–2125	1115 × 2183	1010	531

Profile type 2 (fitting behind the opening) S, M, L-ribbed, S-panelled			
LF of the opening	Ordering sizes = RAM	DRH from FFL	B
855–875 × 1990–2000	990 × 2058	1050	500
855–875 × 2115–2125	990 × 2183	1050	531
980–1000 × 1990–2000	1115 × 2058	1050	500
980–1000 × 2115–2125	1115 × 2183	1050	531

Profile type 2 (fitting in the opening) S, M, L-ribbed			
LF of the opening	Ordering sizes = RAM	DRH from FFL	B
875 × 2000	855 × 1990	1050	500
875 × 2125	855 × 2115	1050	531
1000 × 2000	980 × 1990	1050	500
1000 × 2125	980 × 2115	1050	531

Note with glazing type D: Min. RAM width 980 mm and min. RAM height 2115 mm for glazing on the upper door section.

(See next page for the legend)

Side Doors

With block frame made of aluminium profiles

Standard sizes

Profile type 1
Narrow leaf frame

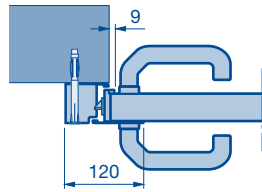

Profile type 2
Wide leaf frame

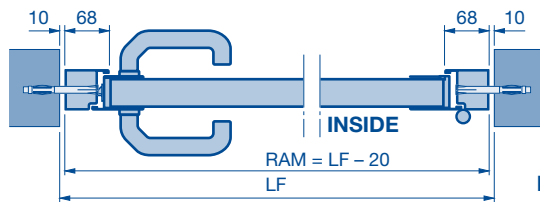
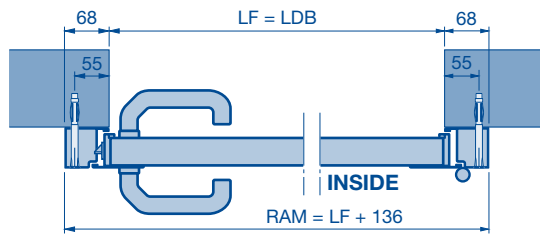
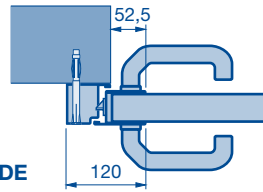

Panel in front of the side door

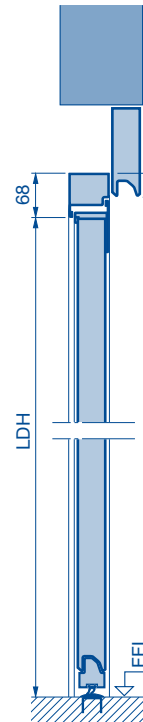

Panel over the side door

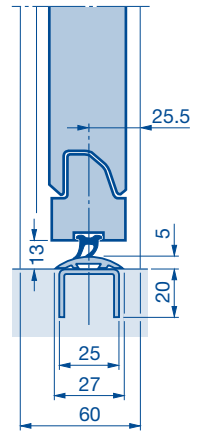
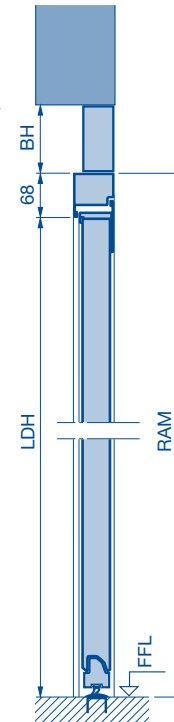

Fitting arrangements

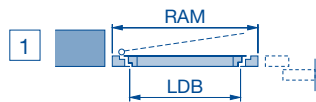

Fitting next to the door, opening outwards, RH hinged

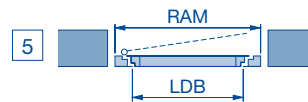

Fitting in the opening, opening outwards, RH or LH hinged

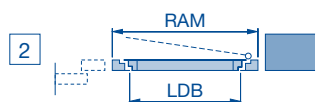

Fitting next to the door, opening outwards, LH hinged

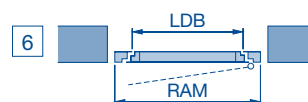

Fitting in the opening, opening inwards, RH or LH hinged

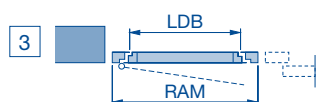

Fitting next to the door, opening inwards, LH hinged

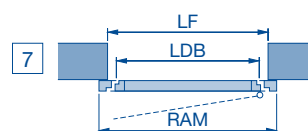

Fitting behind the opening, only opening inwards, RH or LH hinged

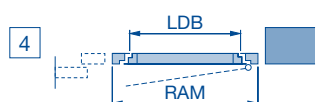

Fitting next to the door, opening inwards, RH hinged

INSIDE

INSIDE

LF Structural opening
LDH Clear passage height
LDB Clear passage width
RAM Overall frame dimension

B Door section height
BH Panel height
DRH Lever height

Side Doors

With block frame made of aluminium profiles

Special sizes

External views

(The illustrations correspond to the size of the structural opening for 1000 x 2125 mm. Deviations may occur with other door sizes.)

Profile type 2



Special sizes (profile type 1, only opening inwards)

Profile type 1 (fitting in or behind the opening) S, M, L-ribbed	
Ordering sizes = RAM	DRH
855 – 1250 x 1990 – 2300	898 – 1064
855 – 1300 x 1990 – 2558	898 – 1064

Profile type 2 (fitting in or behind the opening) S, M, L-ribbed	
Ordering sizes = RAM	DRH
855 – 1250 x 1933 – 2300	1050
855 – 1300 x 1933 – 2558	1050

Profile type 1 (fitting only behind the opening) S-panelled or door style	
Ordering sizes = RAM	DRH
950 – 1250 x 2058 or 2183	898 – 1064
950 – 1300 x 2013, 2058, 2138, 2183, 2263, 2308, 2433 or 2558	898 – 1064

Profile type 2 (fitting only behind the opening, in the opening and opening outwards on request), S-panelled	
Ordering sizes = RAM	DRH
950 – 1250 x 2058 or 2183	1050
950 – 1300 x 1943, 2013, 2058, 2138, 2183, 2263, 2308, 2443 or 2558	1050

Note with glazing type D: Min. RAM width 980 mm and min. RAM height 2115 mm for glazing on the upper door section.

(See next page for the legend)

Side Doors

With block frame made of aluminium profiles

Special sizes

Fitting next to the door, opening outwards, RH or LH hinged

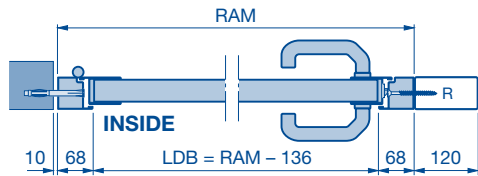

Fitting next to the door, opening inwards, RH or LH hinged

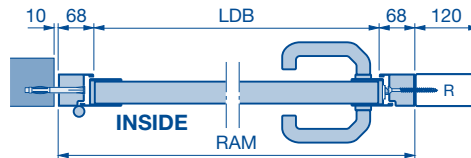

Fitting in the opening, opening inwards or outwards, RH or LH hinged

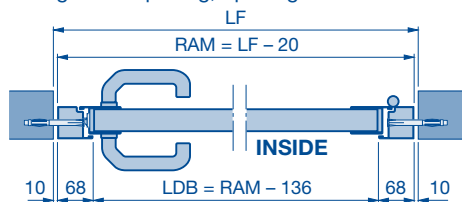

Fitting behind the opening, opening inwards, RH or LH hinged

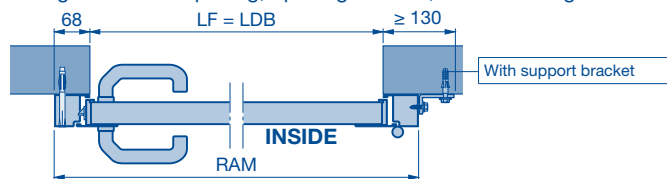

Fitting behind the opening

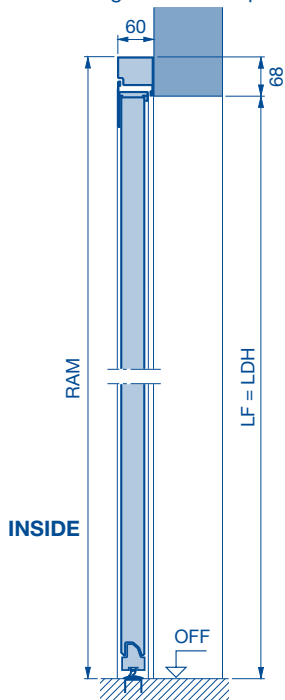

Fitting in the opening

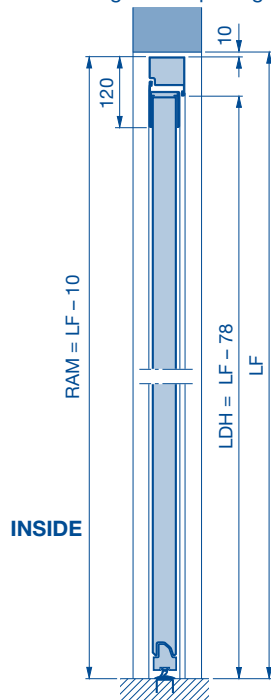

R Box section
 LF Structural opening
 LDH Clear passage height
 LDB Clear passage width

RAM Overall frame dimension
 DRH Lever height

Timber Side Doors

Standard / special sizes

External views

(The illustrations correspond to the size of the structural opening for 1000 × 2125 mm. Deviations may occur with other door sizes.)

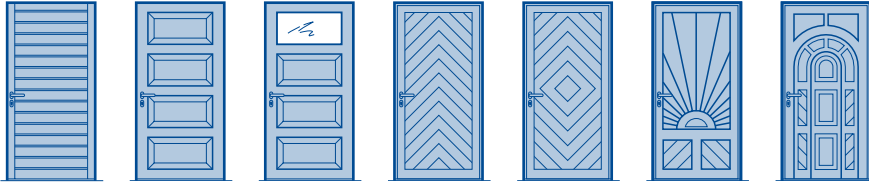

S-ribbed or V-panelled version			
Structural opening	Ordering sizes = RAM	Lever handle height from FFL	Spacing
Standard sizes			
855–875 × 2115–2125	1005–2190	1050	133
980–1000 × 2115–2125	1130–2190	1050	133
Special sizes	990–1250 × 1940–2315	1050	

Style version		
Structural opening	Ordering sizes = RAM	Lever handle height from FFL
Standard sizes		
980–1000 × 2115–2125	1130–2190	1050
Special sizes	1130–1250 × 1940–2315	1050

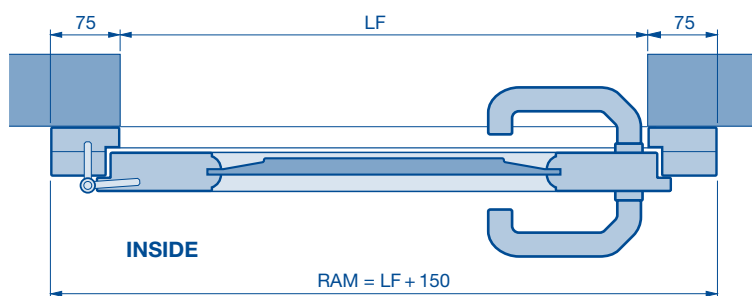
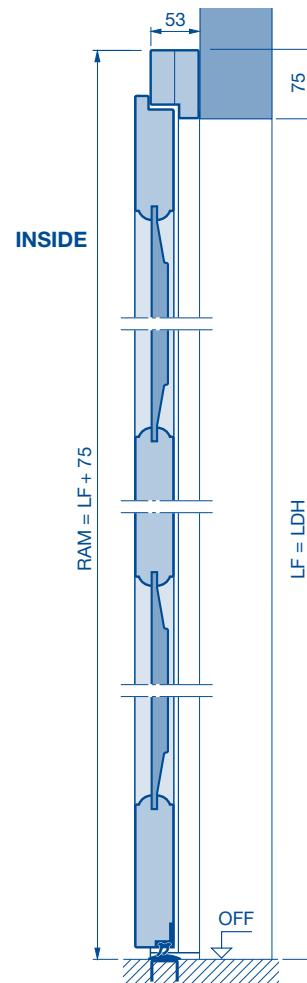

- LF** Structural opening
- LDH** Clear passage height
- RAM** Overall frame dimensions

Garage Door Operators

ProMatic, SupraMatic E, P, H

Track application Z

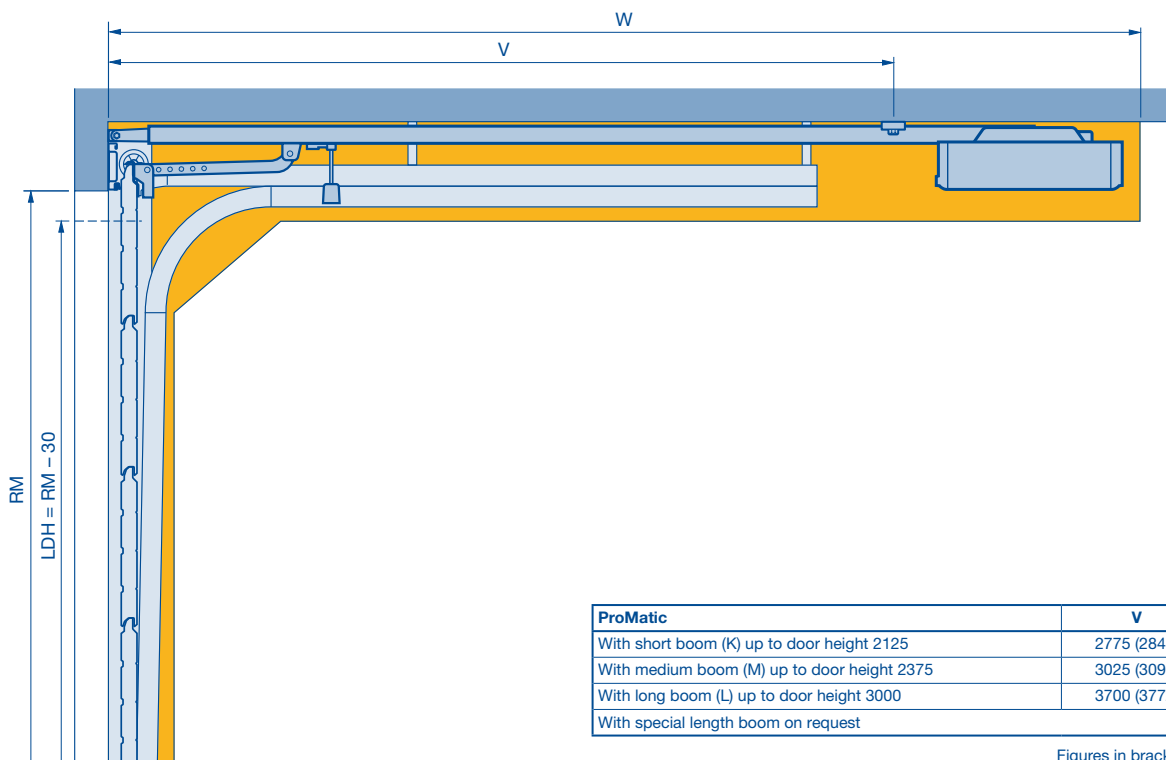

ProMatic	V	W
With short boom (K) up to door height 2125	2775 (2847)	3200 (3272)
With medium boom (M) up to door height 2375	3025 (3097)	3450 (3522)
With long boom (L) up to door height 3000	3700 (3772)	4125 (4197)
With special length boom on request		

Figures in brackets for track application BZ

Track application N

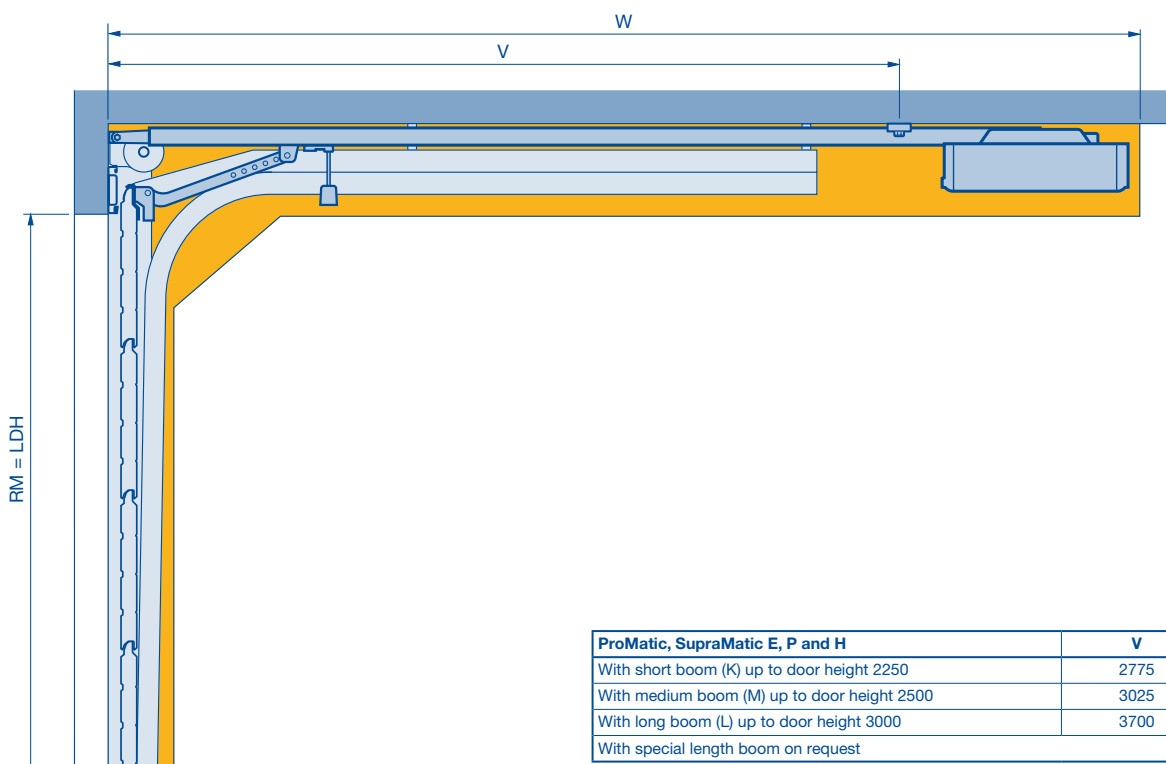

ProMatic, SupraMatic E, P and H	V	W
With short boom (K) up to door height 2250	2775	3200
With medium boom (M) up to door height 2500	3025	3450
With long boom (L) up to door height 3000	3700	4125
With special length boom on request		

For further details, refer to the ProMatic and SupraMatic E/P/H fitting and operating instructions.

RM Grid height
LDH Clear passage height

Garage Door Operators

ProMatic, SupraMatic E, P, H

Track application L

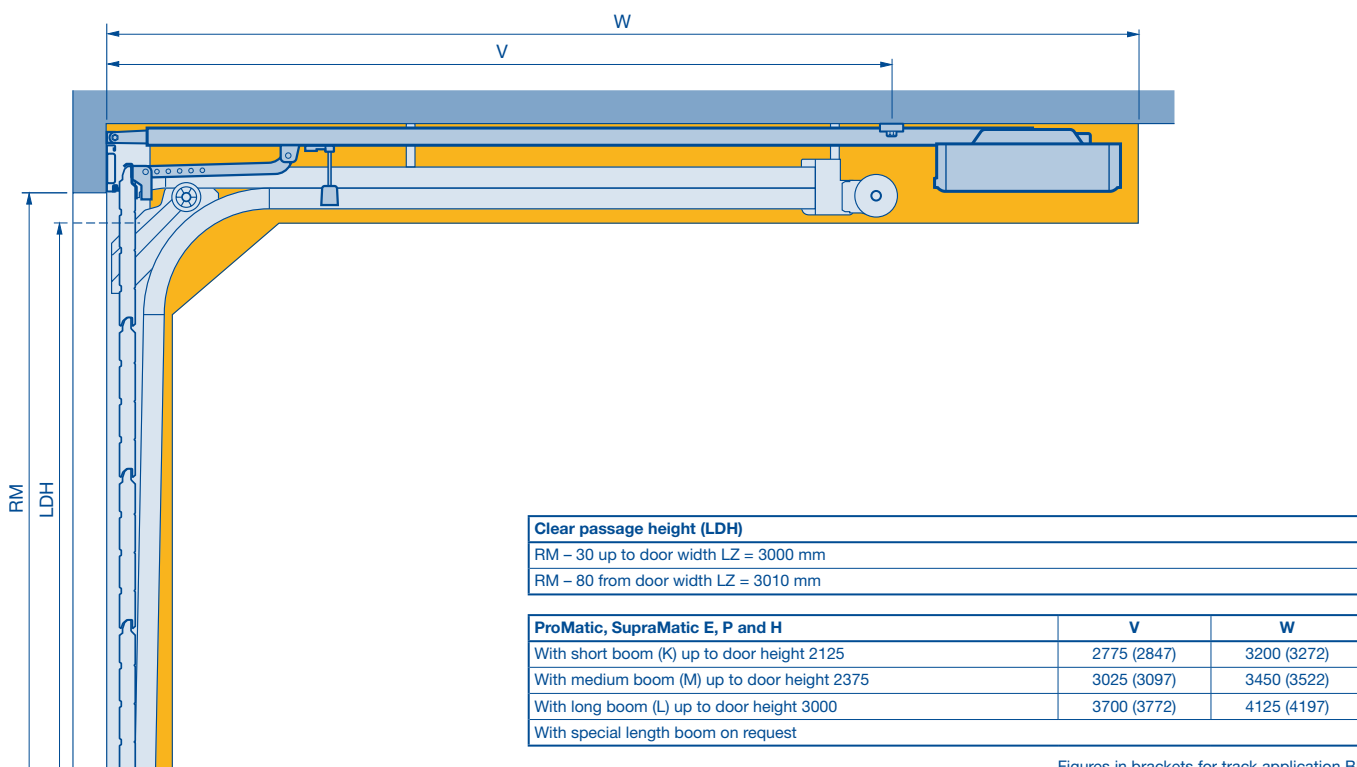

Figures in brackets for track application BL

Track application H

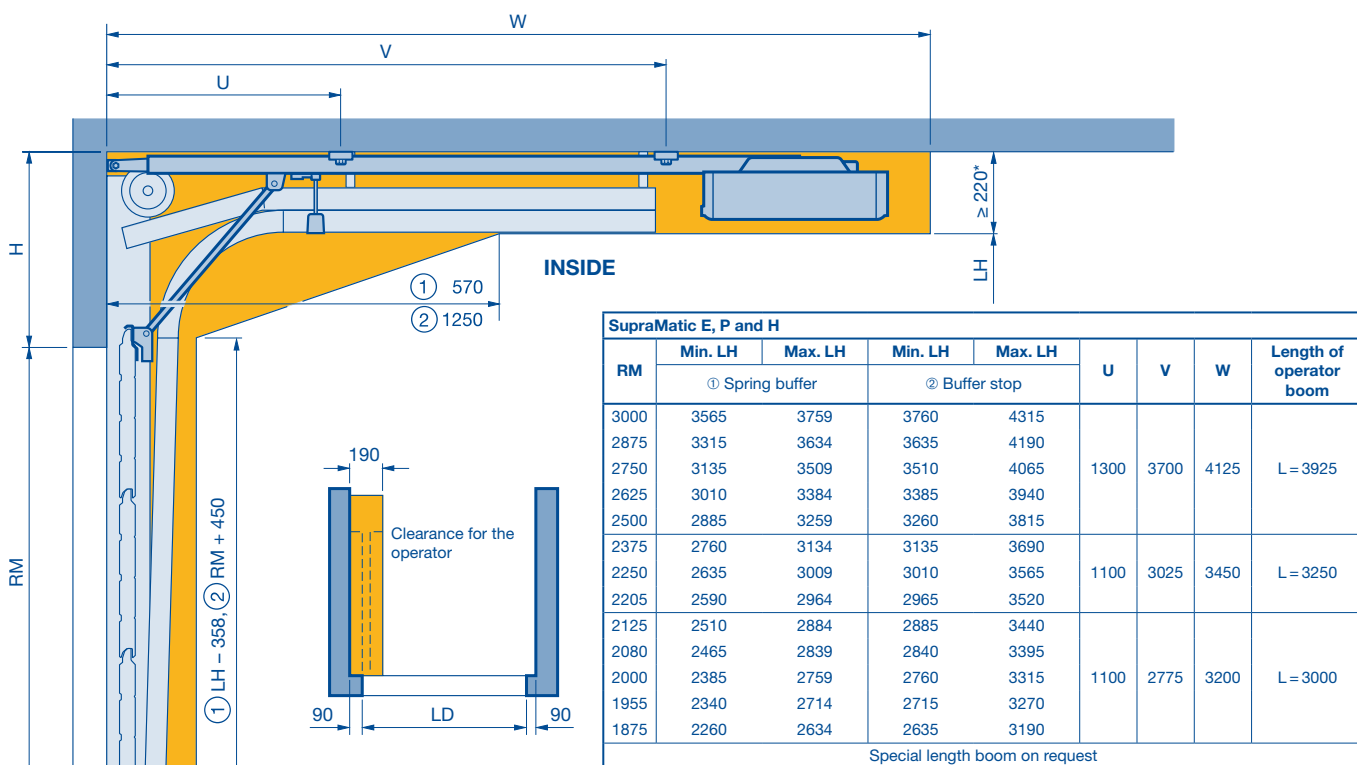

For further details, refer to the ProMatic and SupraMatic E/P/H fitting and operating instructions.

RM Grid height * with ThermoFrame ≥ 255
LDH Clear passage height

Garage Door Operators

SupraMatic HD

Track application N as industry version (galvanized frame)

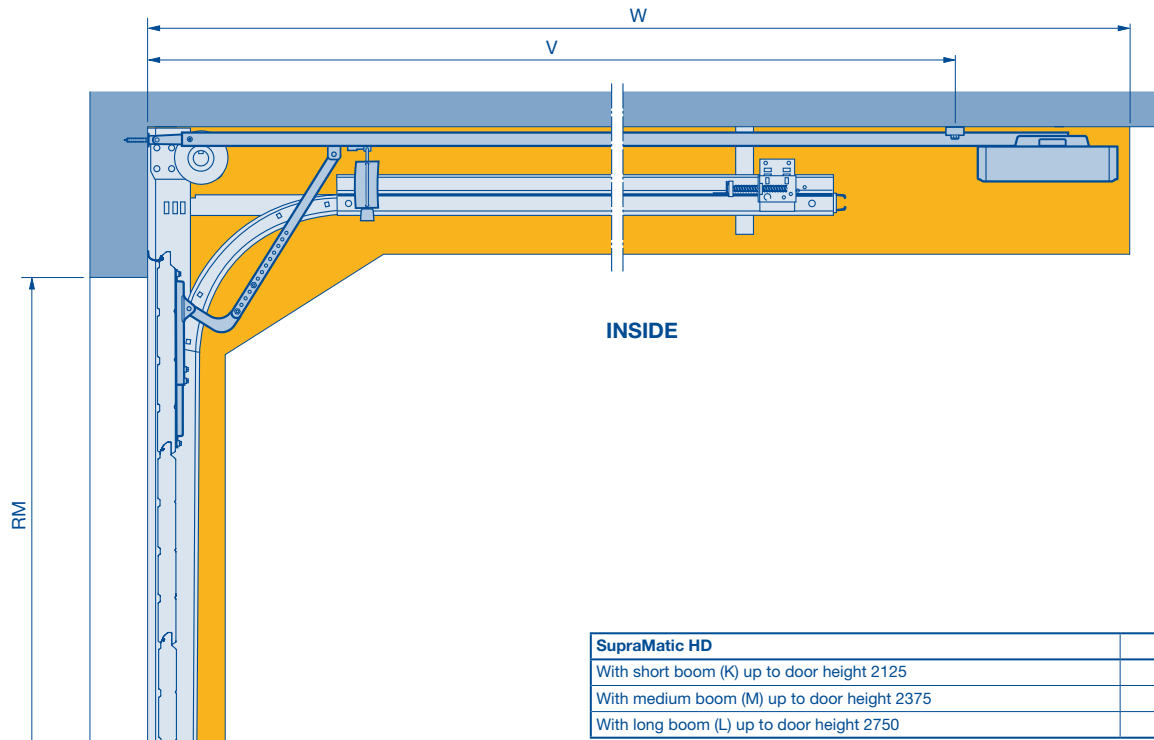

Track application L as industry version (galvanized frame)

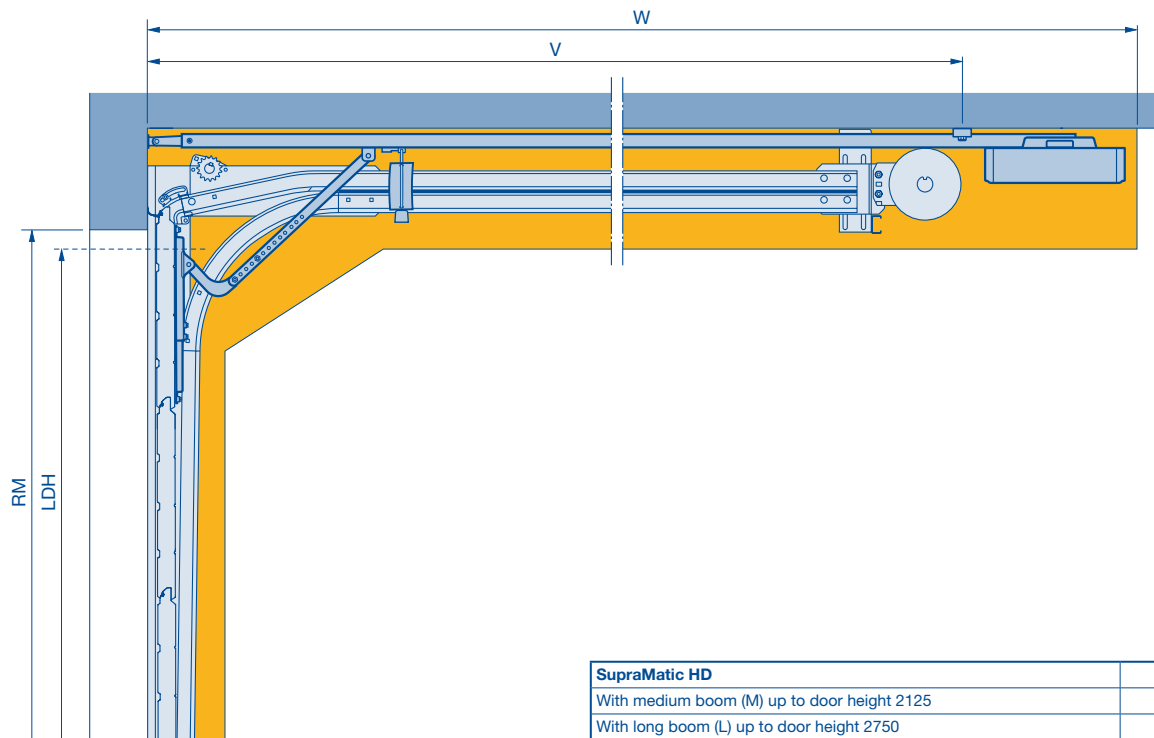

For further details, refer to the SupraMatic HD fitting and operating instructions.

RM Grid height
LDH Clear passage height

Notes

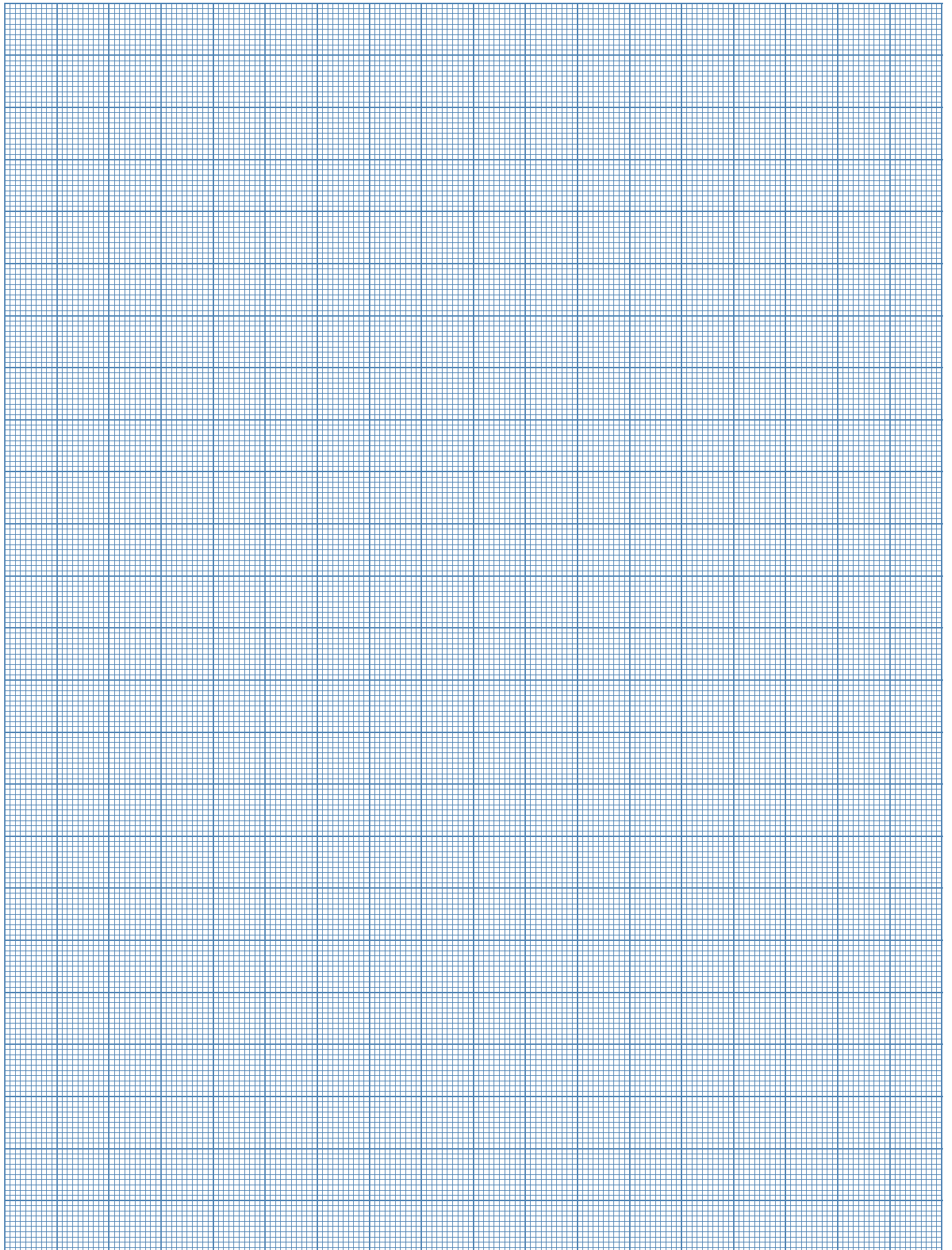

Notes

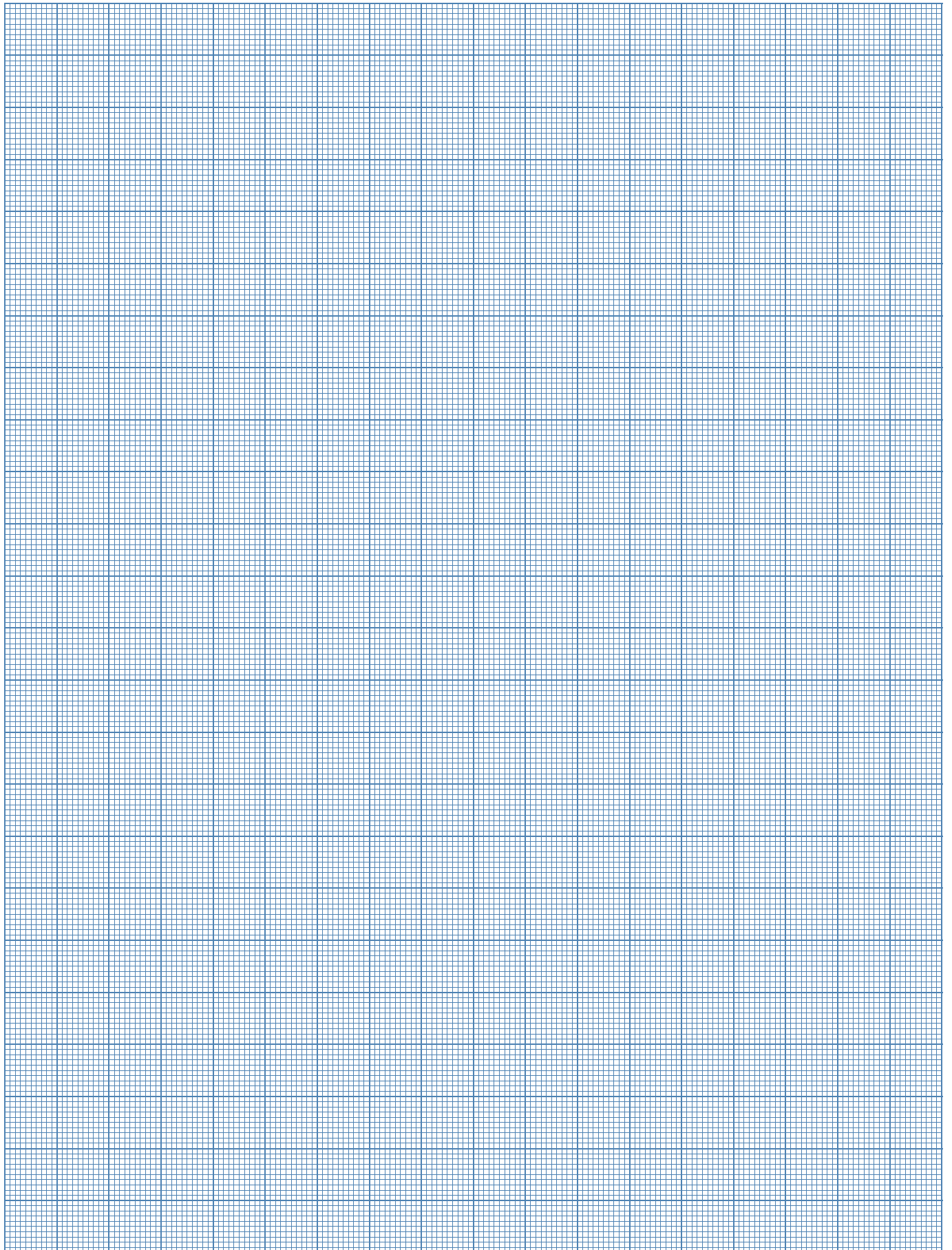

Hörmann: Quality without Compromise



Hörmann KG Amshausen, Germany



Hörmann KG Antriebstechnik, Germany



Hörmann KG Brandis, Germany



Hörmann KG Brockhagen, Germany



Hörmann KG Dissen, Germany



Hörmann KG Eckelhausen, Germany



Hörmann KG Freisen, Germany



Hörmann KG Ichtershhausen, Germany



Hörmann KG Werne, Germany



Hörmann Genk NV, Belgium



Hörmann Alkmaar B.V., Netherlands



Hörmann Legnica Sp. z o.o., Poland



Hörmann Beijing, China



Hörmann Tianjin, China

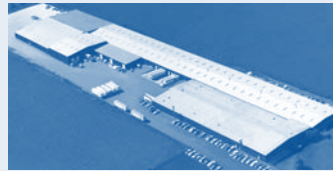

Hörmann LLC, Montgomery IL, USA



Hörmann Flexon, Leetsdale PA, USA

Hörmann is the only manufacturer worldwide that offers you a complete range of all major building products from one source. We manufacture in highly-specialised factories using the latest production technologies. The close-meshed network of sales and service companies throughout Europe, and activities in the USA and China, make Hörmann your strong partner for first-class building products, offering “Quality without Compromise”.

GARAGE DOORS

OPERATORS

INDUSTRIAL DOORS

LOADING EQUIPMENT

HINGED DOORS

DOOR FRAMES

Hörmann (UK) Ltd, Gee Road, Coalville, Leicestershire LE67 4JW
Phone (01530) 513000, Fax (01530) 513001

