

UTILEV[®]
THE UTILITY
LIFT TRUCK[™]

UT50-70P

5000 - 7000kg

Technical
Specifications



Utility you can trust[™]

www.utilev.com

UT50-70P Specifications

Characteristics	1.1	Manufacturer		UTILEV	UTILEV	UTILEV	UTILEV	UTILEV	UTILEV	
	1.2	Model designation		UT50P	UT50P	UT60P	UT60P	UT70P	UT70P	
	1.3	Power: battery, diesel, LPG, electric mains		Diesel	Dual Fuel	Diesel	Dual Fuel	Diesel	Dual Fuel	
	1.4	Operation: manual, pedestrian, stand, seat, orderpicker		Seat	Seat	Seat	Seat	Seat	Seat	
	1.5	Load capacity	Q (kg)	5000	5000	6000	6000	7000	7000	
	1.6	Load centre	c (mm)	600	600	600	600	600	600	
	1.8	Load distance	x (mm)	595	595	595	595	605	605	
	1.9	Wheelbase	y (mm)	2250	2250	2250	2250	2250	2250	
	Weight	2.1	Unladen weight	kg	7800	7750	8200	8150	9100	9050
2.2		Axle loading with load front/rear	kg	11350/1520	11320/1500	12780/1510	12750/1490	14780/1390	14750/1370	
2.3		Axle loading without load, front/rear	kg	3800/4000	3770/3980	3650/4550	3620/4530	3970/5130	3940/5110	
Wheels and Tyres	3.1	Tyres: L = pneumatic, V = cushion, SE = superelastic		L	L	L	L	L	L	
	3.2	Tyre size, front		8.25-15-14PR	8.25-15-14PR	8.25-15-14PR	8.25-15-14PR	8.25-15-14PR	8.25-15-14PR	
	3.3	Tyre size, rear		8.25-15-14PR	8.25-15-14PR	8.25-15-14PR	8.25-15-14PR	8.25-15-14PR	8.25-15-14PR	
	3.5	Number of wheels, front/rear (X = driven)		4X/2	4X/2	4X/2	4X/2	4X/2	4X/2	
	3.6	Track width, front	b10 (mm)	1489	1489	1489	1489	1489	1489	
	3.7	Track width, rear	b11 (mm)	1460	1460	1460	1460	1460	1460	
	Dimensions	4.1	Mast tilt, forward α /back β	degrees	6/12	6/12	6/12	6/12	6/12	6/12
4.2		Height of mast, lowered	h1 (mm)	2500	2500	2500	2500	2500	2500	
4.3		Free lift ▲	h2 (mm)	160	160	160	160	160	160	
4.4		Lift height ▲	h3 (mm)	3000	3000	3000	3000	3000	3000	
4.5		Height of mast, extended +	h4 (mm)	4410	4410	4410	4410	4410	4410	
4.7		Height to top of overhead guard ○	h6 (mm)	2340	2340	2340	2340	2340	2340	
4.8		Seat height ✕	h7 (mm)	1280	1280	1280	1280	1280	1280	
4.12		Towing coupling height	h10 (mm)	450	450	450	450	450	450	
4.19		Overall length	l1 (mm)	4660	4660	4710	4710	4790	4790	
4.20		Length to face of forks	l2 (mm)	3460	3460	3510	3510	3590	3590	
4.21		Overall width, Std/Dual	b1/b2 (mm)	1990	1990	1990	1990	1990	1990	
4.22		Fork dimensions	s/e/l (mm)	60x150x1220	60x150x1220	60x150x1220	60x150x1220	65x150x1220	65x150x1220	
4.23		Fork carriage to DIN 15173. Class, A/B		IVA	IVA	IVA	IVA	IVA	IVA	
4.24		Fork carriage width ●	b3 (mm)	1680	1680	1680	1680	1680	1680	
4.31		Ground clearance under mast, with load	m1 (mm)	170	170	170	170	170	170	
4.32		Ground clearance at centre of wheelbase	m2 (mm)	270	270	270	270	270	270	
4.33		Aisle width with pallets 1000mm long x 1200mm wide	Ast (mm)	4955	4955	4995	4995	5085	5085	
4.34		Aisle width with pallets 800mm wide x 1200mm long	Ast (mm)	5155	5155	5195	5195	5285	5285	
4.35		Outer turning radius	Wa (mm)	3160	3160	3200	3200	3280	3280	
4.36	Inner turning radius	b13 (mm)	1095	1095	1095	1095	1095	1095		
Performance	5.1	Travel speed with/without load	km/h	22/23	23/24	22/23	23/24	22/23	23/24	
	5.2	Lifting speed with/without load	m/sec	0.44/0.45	0.43/0.43	0.44/0.45	0.43/0.43	0.42/0.42	0.38/0.38	
	5.3	Lowering speed with/without load	m/sec	0.45/0.38	0.45/0.38	0.45/0.38	0.45/0.38	0.45/0.38	0.45/0.38	
	5.5	Drawbar pull with/without load, @ 1.6km/h	N	57000/26000	41000/26000	57000/26000	41000/26000	57000/26000	41000/26000	
	5.6	Maximum drawbar pull with/without load	N	76500/26000	60400/26000	76500/26000	60400/26000	76500/26000	60400/26000	
	5.7	Gradeability with/without load, @ 4.8km/h	%	29/33	16/33	26/30	14/30	23/29	13/29	
	5.8	Maximum gradeability with/without load	%	53/33	35/33	45/30	30/30	38/29	27/29	
	5.10	Service brake		Hydraulic	Hydraulic	Hydraulic	Hydraulic	Hydraulic	Hydraulic	
	Engine	7.1	Engine manufacturer/type		CUMMINS/GS83.3	GM 4.3L	CUMMINS/GS83.3	GM 4.3L	CUMMINS/GS83.3	GM 4.3L
		7.2	Engine output, in accordance with ISO1585	kW	74	74	74	74	74	74
7.3		Governed speed	rpm	2200	2300	2200	2300	2200	2300	
7.4		Number of cylinders/displacement	cm3	4/3300	6/4294	4/3300	6/4294	4/3300	6/4294	
Other	8.1	Drive control		Automatic	Automatic	Automatic	Automatic	Automatic	Automatic	
	8.2	Working pressure for attachments	bar	190	190	190	190	190	190	
	8.3	Oil flow for attachments ●	l/min	132	128	132	128	141	128	
	8.4	Average noise level at operator's ear ★	dB(A)	87	87	87	87	87	87	
		Guaranteed sound power 2001/14/EC	dB	107	107	107	107	107	107	
	8.5	Towing coupling type		Pin	Pin	Pin	Pin	Pin	Pin	
		Hydraulic Tank - capacity (drain & refill)	litres	120	120	120	120	120	120	
		Fuel Tank - Capacity (Diesel-Powered Units Only)	litres	120	120	120	120	120	120	
	Step Height (from ground to running board)	mm	650	650	650	650	650	650		
	Step Height (between intermediate steps between running board and floor)	mm	330	330	330	330	330	330		

★ LPAZ, measured according to the test cycles and based on the weighting values contained in EN12053

▲ Bottom of Forks

✕ Non-suspension seat specified

+ With load backrest

● Add 150mm with load backrest

○ h6 subject to +/- 5 mm tolerance. When full-suspension seat or cab is fitted, overhead guard height is raised by 30mm

● Variable

Specification data is based on VDI 2198, with the following configuration:

Complete truck with 3000mm 2-stage limited free lift mast, standard carriage and 1220mm forks, overhead guard and standard pneumatic drive and steer tyres.

UT50-70P Mast Table

Mast Type	Maximum Fork Height (mm)	Lowered Height (mm)	Overall Extended Height	Free Lift	Mast Tilt
			With LBR (mm)	With LBR (mm)	Forward / Back (deg)
2 Stage LFL	3000	2500	4410	160	6/12
	4300	3200	5710	160	6/6
	5500	3850	6910	160	3/6
3 Stage FFL	4800	2825	6210	1425	6/6
	5500	3075	6910	1675	3/6

UT50-70P Capacity Table

Capacity in kg @ 600mm Load Centre

Mast Type	Maximum Fork Height (mm)	Dual Pneumatic / Superelastic Tyres					
		Without Integral Sideshift or Fork Positioner			With Integral Sideshift or Fork Positioner		
		UT50P	UT60P	UT70P	UT50P	UT60P	UT70P
2 Stage LFL	3000	5000	6000	7000	4600	5600	6600
	4300	5000	6000	7000	4600	5600	6600
	5500	4750	5700	6600	4350	5300	6200
3 Stage FFL	4800	4500	5600	6200	4100	5200	5800
	5500	4200	5300	6000	3800	4900	5600

Truck Dimensions

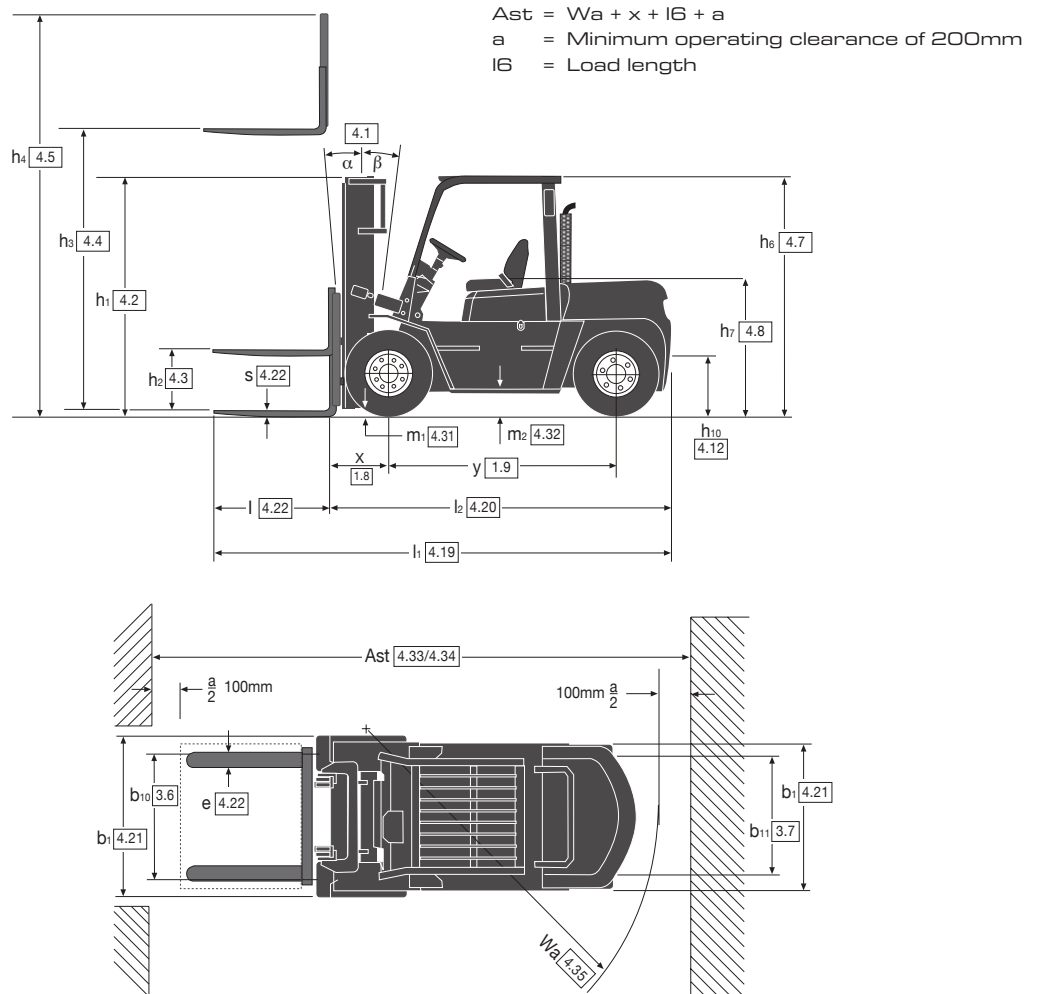

Overview

Utility you can trust™

The UTILEV® range of affordable forklift trucks delivers reliable and cost-effective materials handling solutions for applications across many industries, particularly where users require equipment without advanced functionality and attachments.

The product range has been designed to be easy to operate and maintain, and is backed up by a standard warranty and comprehensive parts availability.

Furthermore, a network of experienced distributors is on-hand to provide maintenance and support, whenever it is required.

Simple to Use

The ergonomically designed operator compartment, with a familiar automotive layout means that drivers will be able

to work comfortably, preventing tiredness during handling operations.

A range of standard features and options help to ensure that the truck is configured to the needs of the application.

Easy to Maintain

Thanks to the simplicity of the components and specification, servicing can be carried out quickly and easily, even when PCs, laptops or diagnostic tools are not available

Affordable to Own

The use of proven, high quality, robust components, efficient filtration and excellent cooling result in reliable operation and lower wear and tear. This - together with the fast availability of cost-effective replacement parts - helps to reduce service and maintenance requirements and costs.

Rated Capacities

Load Centre

Distance from forks to centre of gravity of load.

Rated Load

Based on vertical masts as shown in VDI table.

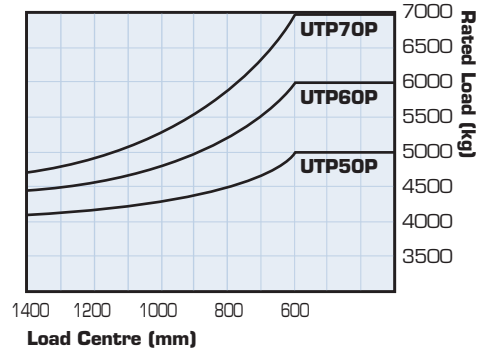

Features

Standard Features Include:

- Engines: Cummins QSB 3.3L Diesel, GM 4.3L Dual Fuel
- Transmission: Autoshift 2-Speed forward, 2 reverse
- Mast: 2-stage LFL 3000mm
- Carriage: 1680mm Class IV
- Forks: 1220x150x60mm Class IV (5.0-6.0t), 1220x150x65mm Class IV (7.0t)
- Pneumatic Tyres Dual Drive: 8.25-15-14PR
- Pneumatic Tyres Steer: 8.25-15-14PR
- Two Function Cowl Mounted Manual Lever - Lift / Tilt
- Forward / Reverse Directional Lever
- Manual Park Brake
- Drum Brakes
- Three Pedal Layout with Mechanical Inching
- Non-Suspension Seat (Vinyl) with Seat Belt
- Steering Wheel with Spinning Knob
- Power Steering and Tilt Adjustable Steering Column
- Key Switch Start
- Entry Grab Handle
- Rear View Mirrors
- Load Backrest
- Dash Display: Fuel Gauge (Diesel/Dual - Fuel), LCD Hour Meter, Water Temperature / Oil Temperature / Transmission Oil Level Warning Lights
- Mast Tilt - 6° Forward / 12° Back
- Strobe Light (magnetically mounted)
- Audible Reverse Alarm
- Light Kit - 2 x Front Work, 2 x Front Turn, Rear Turn / Tail / Brake / Reverse
- Upswept Exhaust
- Standard Overhead Guard (2340mm)
- Radiator with Transmission Oil Cooler
- Cyclonic Air Filter

- Fixed Tank Bracket (LPG Trucks)
- Fuel Tank Capacity - 120L
- Engine Hood Lock
- Mast Tilt Gaitor
- Counterweight Net
- Toolbox
- Towing Pin
- Operator Manual
- 12 Months / 2000 Hours Manufacturer's Warranty

Options

- 2-stage LFL and 3-stage FFL Masts up to 5.5m
- Mast Tilt - 6° Forward / 6° Back or 6° Forward / 3° Back
- Carriage - 1900mm (Class IV)
- Forks 1520, 1820 and 2440mm (Class IV)
- Integral Sideshift or Integral Sideshift with Fork Positioner
- Valve and Hose Groups - 3 and 4 Way
- Counterweight Exhaust
- Air Intake with Pre-cleaner
- Cab with/without Heater ○
- Full Suspension Seat ○
- High Overhead Guard (2370mm) ○
- Rear Work Light
- Superelastic Dual Drive and Steer Tyres
- Non-Marking Superelastic Dual Drive and Steer Tyres
- Operator Presence System
- PVC Rain Cover
- Air Conditioning
- Swing Out LPG Bracket
- Battery Disconnect Device

UTILEV®
THE UTILITY
LIFT TRUCK™

These trucks conform to current legislative requirements. Specification is subject to change without notice. Trucks shown with optional equipment.

Publication part no. U00063 Rev.00. Designed in The United Kingdom.
© NACCO Materials Handling Ltd 2014. All rights reserved.

UTILEV is a registered trademark.
THE UTILITY LIFT TRUCK and UTILITY YOU CAN TRUST are trademarks in the United States and certain other jurisdictions.
NACCO Materials Handling Limited, Centennial House, Frimley Business Park, Frimley, Surrey GU16 7SG, United Kingdom.
Tel: + 44 (0) 1276 538500, Fax: + 44 (0) 1276 538559
www.utilev.com